

Installation Guide



FibeAir[®] IP-20C FibeAir[®] IP-20C Assured

March 2019

Part ID: BM-0266-0 | Doc ID: DOC-00036522 | Rev E.01

© Copyright 2019 by Ceragon Networks Ltd. All rights reserved.

Notice

This document contains information that is proprietary to Ceragon Networks Ltd. No part of this publication may be reproduced, modified, or distributed without prior written authorization of Ceragon Networks Ltd. This document is provided as is, without warranty of any kind.

Trademarks

Ceragon Networks®, FibeAir® and CeraView® are trademarks of Ceragon Networks Ltd., registered in the United States and other countries.

Ceragon® is a trademark of Ceragon Networks Ltd., registered in various countries.

CeraMap™, PolyView™, EncryptAir™, ConfigAir™, CeraMon™, EtherAir™, CeraBuild™, CeraWeb™, and QuickAir™, are trademarks of Ceragon Networks Ltd.

Other names mentioned in this publication are owned by their respective holders.

Statement of Conditions

The information contained in this document is subject to change without notice. Ceragon Networks Ltd. shall not be liable for errors contained herein or for damage in connection with the furnishing, performance, or use of this document or equipment supplied with it.

Open Source Statement

The Product may use open source software, among them O/S software released under the GPL or GPL alike license ("Open Source License"). Inasmuch that such software is being used, it is released under the Open Source License, accordingly. The complete list of the software being used in this product including their respective license and the aforementioned public available changes is accessible at:

Network element site: <ftp://ne-open-source.license-system.com>

NMS site: <ftp://nms-open-source.license-system.com/>

Information to User

Any changes or modifications of equipment not expressly approved by the manufacturer could void the user's authority to operate the equipment and the warranty for such equipment.

Intended Use/Limitation

Fixed point-to-point radio links for private networks.

Authorized to Use

Only entities with individual authorization from the National Regulator to operate the mentioned radio equipment.

The equipment can be used in the following EU countries:

Austria (AT) - Belgium (BE) - Bulgaria (BG) - Switzerland/Liechtenstein (CH) - Cyprus (CY) - Czech Republic (CZ) - Germany (DE) - Denmark (DK) - Estonia (EE) - Finland (FI) - France (FR) - Greece (GR) - Hungary (HU) - Ireland (IE) - Iceland (IS) - Italy (IT) - Lithuania (LT) - Luxembourg (LU) - Latvia (LV) - Malta (MT) - Netherlands (NL) - Norway (NO) - Portugal (PT) - Romania (RO) - Sweden (SE) - Slovenia (SI) - Slovak Republic (SK) - United Kingdom (UK) - Spain (SP) - Poland (PL)

Table of Contents

1. Before You Start	9
1.1 Important Notes	9
1.2 Safety Precautions & Declared Material.....	9
1.2.1 Public and Occupational Boundary Distances Under Article 3.1(a) of the RE Directive	9
1.2.2 General Equipment Precautions.....	9
1.2.3 Précautions générales relatives à l'équipement.....	10
1.2.4 Allgemeine Vorsichtsmaßnahmen für die Anlage	11
1.3 Pre-Installation Instructions	11
1.3.1 Packing.....	11
1.3.2 Transportation and Storage.....	11
1.3.3 Unpacking	11
1.3.4 Inspection	12
1.4 FibeAir IP-20 Assured Platform.....	12
2. Product Hardware Description	13
2.1 IP-20C Hardware Overview.....	13
2.1.1 IP-20C Interfaces.....	14
2.1.2 Channel-Port Mapping to Polarization	18
2.2 MultiCore Mediation Devices (MCMD)	20
2.3 PoE Injector	21
2.3.1 PoE Injector Interfaces	22
2.4 System Components.....	23
2.5 Adaptors and Installation Kits.....	24
2.6 Antenna Connection.....	30
2.7 Power Specifications.....	31
2.7.1 Electrical Requirements.....	31
2.7.2 Important Notes!	31
2.8 Environmental Specifications	31
3. Cable Installation and Grounding.....	32
3.1 Minimum and Maximum Cable Diameter	32
3.2 Grounding the Cables	32
3.3 Grounding the IP-20C Unit	35
3.4 Power Source.....	36
3.5 Surge Protection.....	36
3.6 Available Cable Options.....	37
3.6.1 Fiber Optic Cables - Single Mode.....	37
3.6.2 Fiber Optic Cables - Multi Mode.....	37
3.6.3 DC Cable and Connector	38
3.6.4 Cables for MIMO Connections.....	38
3.6.5 Ethernet Cable and Specifications	38
3.6.6 Outdoor Ethernet Cable Specifications	40
3.6.7 Outdoor DC Cable Specifications.....	41

- 3.7 Securing the Cables 41
- 3.8 Special Instructions for use of Glands 42
 - 3.8.1 General Installation Procedure..... 43
- 3.9 Connecting an Optical Fiber Cable and SFP 48
- 3.10 Connecting a DC Power Cable 52
- 3.11 Connecting the Ethernet Cable..... 54
 - 3.11.1 Preparing the Ethernet Cable and Plug-in Field..... 55
 - 3.11.2 Preparing the Ethernet Cable Already Assembled 57
 - 3.11.3 Connection of Ethernet Cable to IP-20C..... 58
 - 3.11.4 Using a Splitter Cable with P2 of a 2E2SX Hardware Model..... 60
- 3.12 Management Connection for 4x4 MIMO and 1+1/2+2 HSB Configurations 61
 - 3.12.1 Preparing a MIMO/Protection Signaling Cable..... 62
 - 3.12.2 Connecting the MIMO/Protection Splitters and Protection Signaling Cable..... 63
- 4. PoE Injector Installation and Connection 64**
 - 4.1 PoE Injector Cable Connection 64
 - 4.2 PoE Injector Grounding 65
 - 4.3 PoE Injector Wall Mount Installation..... 65
 - 4.4 PoE Injector Pole Mount Installation 67
 - 4.5 PoE Injector 19” Rack Installation..... 68
 - 4.6 PoE Injector ETSI Rack Installation..... 70
- 5. Generic Installation Procedures 72**
 - 5.1 General Notes Concerning All Installation Procedures..... 72
 - 5.2 Torque Requirements 73
 - 5.3 IP-20C DC Pole Mount Procedure..... 74
 - 5.4 Remote Mount Installation for Single Polarization with an Imperial Waveguide 76
 - 5.4.1 6-13GHz Installation Procedure..... 76
 - 5.4.2 15-42GHz Installation Procedure..... 78
- 6. Installation Procedures per Configuration Type..... 81**
 - 6.1 MultiCore 2+0 Dual Polarization Direct Mount 81
 - 6.2 MultiCore 2+0 Dual Polarization Remote Mount 82
 - 6.2.1 Common Installation 84
 - 6.2.2 6-13 GHz 85
 - 6.2.3 15-42 GHz 87
 - 6.3 MultiCore 2+0 Single Polarization Direct Mount 88
 - 6.4 MultiCore 2+0 Single Polarization Remote Mount..... 90
 - 6.4.1 6-13 GHz 90
 - 6.4.2 15-42 GHz 92
 - 6.5 MultiCore 2+2 HSB Double Polarization Direct Mount..... 94
 - 6.6 MultiCore 2+2 HSB Double Polarization Remote Mount..... 98
 - 6.6.1 Common Installation 99
 - 6.6.2 6-13 GHz 101

- 6.6.3 15-42 GHz 103
- 6.7 MultiCore 2+2 HSB Single Polarization Direct Mount..... 105
- 6.8 MultiCore 2+2 HSB Single Polarization Remote Mount..... 109
 - 6.8.1 6-13 GHz 110
 - 6.8.2 15-42 GHz 113
- 6.9 2 x MultiCore 2+0 Dual Polarization Direct Mount..... 116
- 6.10 2 x MultiCore 2+0 Dual Polarization Remote Mount..... 118
 - 6.10.1 Common Installation Procedure 119
 - 6.10.2 6-13 GHz 120
 - 6.10.3 15-42 GHz 122
- 6.11 2 x MultiCore 2+0 Single Polarization Direct Mount 123
- 6.12 2x2 LoS MIMO Direct Mount 126
- 6.13 2x2 LoS MIMO Remote Mount 130
 - 6.13.1 For 6-13 GHz 131
 - 6.13.2 15-42GHz 132
- 6.14 4x4 LoS MIMO Direct Mount 133
- 6.15 4+0 Dual Polarization, 2+2HSB Single/Dual Polarization Direct Mount 137
 - 6.15.1 4+0 with Dual Circulator (6-11GHz) Direct Mount 138
- 6.16 4+0 Dual Polarization, 2+2HSB Dual Polarization Remote Mount..... 138
 - 6.16.1 6-13GHz 139
 - 6.16.2 15-42GHz 141
 - 6.16.3 4+0 with Dual Circulator (6-11GHz) Remote Mount 143
- 6.17 2+2HSB Single Polarization Remote Mount..... 144
 - 6.17.1 6-13GHz 144
- 6.18 1+1 HSB-SD 147
 - 6.18.1 6-13GHz 147
 - 6.18.2 15-42GHz 149
- 6.19 Dual Circulator Multi-Carrier Kit Installation 151
 - 6.19.1 6-8 GHz 151
 - 6.19.2 11 GHz only..... 152
 - 6.19.3 6-11GHz 153
- 6.20 AFR 1+0 Hub Site 157
 - 6.20.1 Common Installation 158
 - 6.20.2 6-13 GHz 159
 - 6.20.3 15-42 GHz 160
- 7. Installing IP-20C on Third-Party Antenna Adaptors..... 162**
 - 7.1 Special Note on Converting ValuLine 3 Antennas 164
- 8. Appendix A: Acceptance & Commissioning Procedures 165**
 - 8.1 Site Acceptance Procedure..... 166
 - 8.2 Site Acceptance Checklist Notes..... 169
 - 8.3 Radio Link Commissioning Procedure 170
 - 8.3.1 Scope 170
 - 8.3.2 Commissioning Test..... 171

8.4 IP-20 Commissioning Log..... 172

List of Figures

Figure 1: IP-20C Rear View (Left) and Front View (Right) 13

Figure 2: Cable Gland Construction 13

Figure 3: IP-20C Interfaces – Descriptive Labels 14

Figure 4: IP-20C Interfaces – Letter Labels 15

Figure 5: IP-20C Interfaces – 2E2SX Model..... 16

Figure 6: Channel Ranges..... 18

Figure 7: V and H Polarization..... 19

Figure 8: IP-20C-HP-6L-252A-7W81W2-H-ESX..... 19

Figure 9: Separation Criteria when Working with Two Diplexer Types 20

Figure 10: Splitter..... 20

Figure 11: OMT 21

Figure 12: PoE Injector 21

Figure 13: PoE Injector Ports 22

Figure 14: IP-20C..... 23

Figure 15: Dual Core Coupler/Splitter..... 23

Figure 16: DC OMT 23

Figure 17: Remote Pole Mount..... 23

Figure 18: Remote Dual Pole Mount 23

Figure 19: DC Splitter 23

Figure 20: Adaptor for 6-13 GHz..... 23

Figure 21: PoE Injector 23

Figure 22: Cable Grounding Kit 32

Figure 23: Cable Design..... 39

Figure 24: Tightening the Front Portion of the Gland 46

Figure 25: Tightening the Rear Portion of the Gland..... 46

Figure 26: MIMO/Protection Signaling Cable Pinouts 62

Figure 27: 4x4 MIMO or HSB Protection Configuration with External Management..... 63

Figure 28: Transparent Pressure Windows..... 72

Figure 29: 4+0 with Dual Circulator (6-11GHz) Direct Mount 138

List of Tables

Table 1: Ethernet Splitter Cable and Gland for Dual Ethernet Port.....	17
Table 2: Channel-Port Mapping, 1W27W8	18
Table 3: Channel-Port Mapping, 7W81W2	19
Table 4: MCMD Comparison	20
Table 5: Adaptors and Installation Kits, 6 GHz – 18 GHz	24
Table 6: Adaptors and Installation Kits, 23 GHz – 38 GHz	25
Table 7: Adaptors and Installation Kits, Remote Mount - 6 GHz – 15 GHz.....	25
Table 8: Adaptors and Installation Kits, Remote Mount - 18 GHz – 42 GHz.....	26
Table 9: 1500P Adaptors - 6GHz – 23 GHz.....	26
Table 10: 1500P Adaptors - 26GHz – 42GHz.....	26
Table 11: Imperial to mm Transitions – 6GHz – 15GHz	27
Table 12: Imperial to mm Transitions – 18GHz – 42GHz	27
Table 13: Antenna Circ. Adapters for OMT – 6GHz – 18GHz.....	28
Table 14: Antenna Circ. Adapters for OMT – 23GHz – 42GHz.....	29
Table 15: PoE Injector	29
Table 16: Antenna Flanges.....	30
Table 17: Cable Grounding Kit	32
Table 18: Fiber Optic Cables - Single Mode	37
Table 19: Fiber Optic Cables - Multi Mode	37
Table 20: DC Cable and Connector	38
Table 21: Cables for MIMO Connections	38
Table 22: Ethernet Cable and Specifications	38
Table 23: Ethernet Cable Color Code.....	39
Table 24: Outdoor Ethernet Cable Specifications – Electrical Requirements.....	40
Table 25: Outdoor Ethernet Cable Specifications – Mechanical/ Environmental Requirements	40
Table 26: Outdoor DC Cable Specifications – Electrical Requirements	41
Table 27: Outdoor DC Cable Specifications – Mechanical/ Environmental Requirements	41
Table 28: Cable Clamps.....	41
Table 29: Glands Kit	42
Table 30: Gland Caps.....	42
Table 31: Materials for Preparing Ethernet Data Cables	55
Table 32: 3 rd -Party Adaptors, 6 GHz – 15 GHz	162
Table 33: 3 rd -Party Adaptors, 18 GHz – 38 GHz	163

About This Guide

This guide describes the FibeAir IP-20C installation procedures and provides additional information concerning system parts and frequency bands.

What You Should Know

For the warranty to be honored, install the unit in accordance with the instructions in this manual.

Target Audience

This guide contains technical information about IP-20C installation, and is intended for use by qualified Ceragon technical personnel at all levels.

Related Documents

- FibeAir IP-20C Technical Description
- User Guide for IP-20 All-Outdoor Products
- IP-20 Series MIB Reference

1. Before You Start

1.1 Important Notes

- For the warranty to be honored, install the unit in accordance with the instructions in this manual.
- Any changes or modifications of equipment not expressly approved by the manufacturer could void the user's authority to operate the equipment and the warranty for such equipment.
- IP-20C is intended for installation in a restricted access location.
- IP-20C must be installed and permanently connected to protective earth by qualified service personnel in accordance with applicable national electrical codes.

1.2 Safety Precautions & Declared Material

1.2.1 Public and Occupational Boundary Distances Under Article 3.1(a) of the RE Directive

Based on the highest nominal output power of the IP-20C:

- The public exposure of compliance boundary distance is 4.8m.
- The occupational exposure of compliance boundary distance is 1.2m. This is the worst case for the highest nominal output power, using 10-13 GHz frequency bands and antennas up to 1 ft. For all other configurations, the compliance boundary distance is 0.

Note that even when the compliance boundary is a non-zero value, this only applies within the bore sight of the antenna dish. Therefore, during work within and close to the front of the antenna, make sure the transmitters are turned off. As long as the transmitters are turned off during any work on the system, the occupational exposure limit is not of concern to workers operating in or around the parabolic dish antenna.

1.2.2 General Equipment Precautions



To avoid malfunctioning or personnel injuries, equipment or accessories/kits/plug-in unit installation, requires qualified and trained personnel. Changes or modifications not expressly approved by Ceragon Networks could void the user's authority to operate the equipment.



Where special cables, shields, adapters and grounding kits are supplied or described in this manual, these items must be used, to comply with the FCC regulations.



Use of controls, adjustments, or performing procedures other than those specified herein, may result in hazardous radiation exposure.



When working with an IP-20C, note the following risk of electric shock and energy hazard:

Disconnecting one power supply disconnects only one power supply module. To isolate the unit completely, disconnect all power supplies.



Machine noise information order - 3. GPSGV, the highest sound pressure level amounts to 70 dB (A) or less, in accordance with ISO EN 7779.



Static electricity may cause body harm, as well as harm to electronic components inside the device. Anyone responsible for the installation or maintenance of the IP-20C must use an ESD Wrist Strap. ESD protection measures must be observed when touching the unit. To prevent damage, before touching components inside the device, all electrostatic must be discharged from both personnel and tools.



In Norway and Sweden:

Equipment connected to the protective earthing of the building installation through the mains connection or through other equipment with a connection to protective earthing – and to a cable distribution system using coaxial cable, may in some circumstances create a fire hazard. Connection to a cable distribution system has therefore to be provided through a device providing electrical isolation below a certain frequency range (galvanic isolator, see EN 60728-11).

Utstyr som er koplet til beskyttelsesjord via nettplugg og/eller via annet jordtilkøpelt utstyr – og er tilkøpelt et kabel-TV nett, kan forårsake brannfare. For å unngå dette skal det ved tilkøpling av utstyret til kabel-TV nettet installeres en galvanisk isolator mellom utstyret og kabel-TV nettet.

Utrustning som är kopplad till skyddsjord via jordat vägguttag och/eller via annan utrustning och samtidigt är kopplad till kabel-TV nät kan i vissa fall medföra risk för brand. För att undvika detta skall vid anslutning av utrustningen till kabel-TV nät galvanisk isolator finnas mellan utrustningen och kabel-TV nätet.

1.2.3 Précautions générales relatives à l'équipement



L'utilisation de commandes ou de réglages ou l'exécution de procédures autres que celles spécifiées dans les présentes peut engendrer une exposition dangereuse aux rayonnements.



L'usage de IP-20C s'accompagne du risque suivant d'électrocution et de danger électrique : le débranchement d'une alimentation électrique ne déconnecte qu'un module d'alimentation électrique. Pour isoler complètement l'unité, il faut débrancher toutes les alimentations électriques.



Bruit de machine d'ordre - 3. GPSGV, le plus haut niveau de pression sonore s'élève à 70 dB (A) au maximum, dans le respect de la norme ISO EN 7779.

1.2.4 Allgemeine Vorsichtsmaßnahmen für die Anlage



Wenn andere Steuerelemente verwendet, Einstellungen vorgenommen oder Verfahren durchgeführt werden als die hier angegebenen, kann dies gefährliche Strahlung verursachen.



Beachten Sie beim Arbeiten mit IP-20C das folgende Stromschlag- und Gefahrenrisiko: Durch Abtrennen einer Stromquelle wird nur ein



Stromversorgungsmodul abgetrennt. Um die Einheit vollständig zu isolieren, trennen Sie alle Stromversorgungen ab.

Maschinenlärminformations-Verordnung - 3. GPSGV, der höchste Schalldruckpegel beträgt 70 dB(A) oder weniger gemäß EN ISO 7779.

1.3 Pre-Installation Instructions

1.3.1 Packing

The equipment should be packed and sealed in moisture absorbing bags.

1.3.2 Transportation and Storage

The equipment cases are prepared for shipment by air, truck, railway and sea, suitable for handling by forklift trucks and slings. The cargo must be kept dry during transportation, in accordance with ETS 300 019-1-2, Class 2.3. For sea-transport, deck-side shipment is not permitted. Carrier-owned cargo containers should be used.

It is recommended that the equipment be transported to the installation site in its original packing case.

If intermediate storage is required, the packed equipment must be stored in a dry and cool environment, and out of direct sunlight, in accordance with ETS 300 019-1-1, Class 1.2.

1.3.3 Unpacking

The equipment is packed in sealed plastic bags and moisture absorbing bags are inserted. Any separate sensitive product, i.e. printed boards, are packed in anti-static handling bags. The equipment is further packed in special designed cases.

Marking is done according to standard practice unless otherwise specified by customers. The following details should be marked:

- Customers address
- Contract No
- Site name (if known)
- Case No

1.3.4 Inspection

Check the packing lists and ensure that correct parts numbers quantities of goods have arrived. Inspect for any damage on the cases and equipment. Report any damage or discrepancy to a Ceragon representative, by e-mail or fax.

1.4 FibeAir IP-20 Assured Platform

Ceragon's FibeAir® IP-20 Assured platform enhances network reliability and security, ensuring that mission-critical networks maintain availability, and protecting the confidentiality and integrity of their users' data.

The FibeAir IP-20 Assured platform is compliant with FIPS 140-2, including:

- Compliance with FIPS 140-2 specifications for cryptography module.
- FIPS 140-2 Level 2 physical security.
- AES-256 encryption (FIPS 197) over radio links.

The FibeAir IP-20 Assured platform also provides:

- Secured communication and protocols for management interface.
- Centralized user authentication management via RADIUS.
- Advanced identity management and password policy enforcement.
- Security events log.
- Secure product architecture and development.

The following products are included in the FibeAir IP-20 Assured platform:

- FibeAir IP-20C Assured
- FibeAir IP-20S Assured
- FibeAir IP-20A Assured
- FibeAir IP-20N Assured
- FibeAir IP-20LH Assured
- FibeAir IP-20G Assured
- FibeAir IP-20GX Assured

Note: FibeAir IP-20 Assured is supported with certain versions of CeraOS. To determine whether a specific CeraOS version supports FibeAir IP-20 Assured, check the Release Notes for the CeraOS version.

2. Product Hardware Description

2.1 IP-20C Hardware Overview

IP-20C features an all-outdoor dual-carrier architecture consisting of a single unit directly mounted on the antenna.

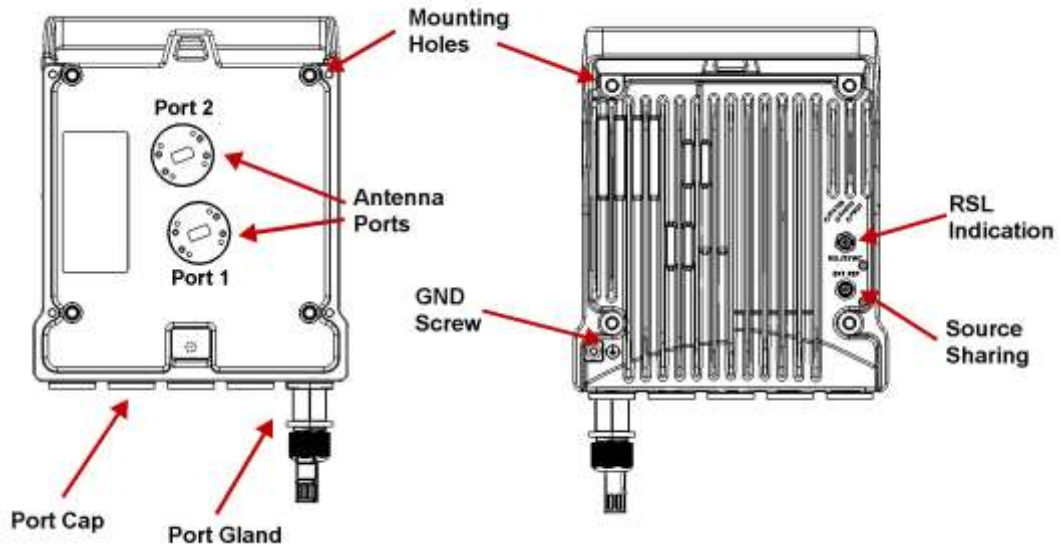

Figure 1: IP-20C Rear View (Left) and Front View (Right)

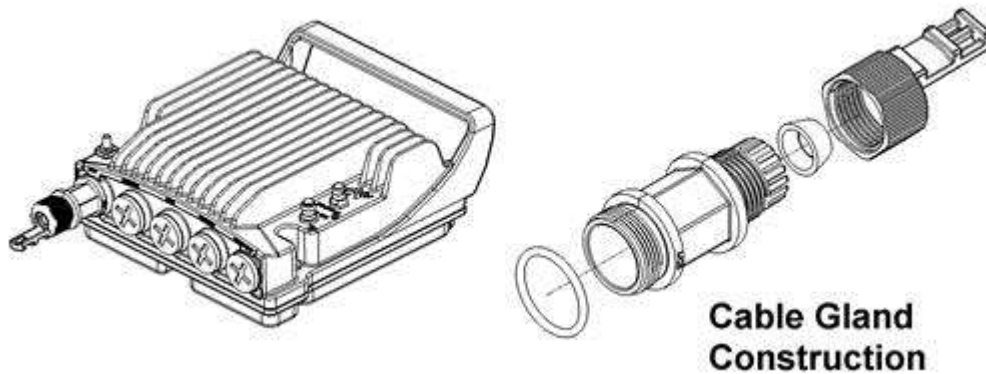

Figure 2: Cable Gland Construction

2.1.1 IP-20C Interfaces

IP-20C is available in several hardware models:

- IP-20C ESS – Includes one RJ-45 port and two SFP ports for Ethernet traffic.
- IP-20C ESX – Includes one RJ-45 port and one SFP port for Ethernet traffic, and an SFP+ port for use as an Extension port with MIMO 4x4 and Space Diversity 2+2 configurations.
- IP-20C 2E2SX – Includes two RJ-45 traffic ports in a single gland, as well as two SFP ports, for a total of up to four available traffic ports. In MIMO 4x4 and Space Diversity 2+2 configurations, one of the SFP ports (P4) is automatically configured to operate as an Extension port.

Two labelling formats are available for the IP-20C ESS and ESX hardware models, as shown in the following figures. Except for the interface labelling, these versions are identical.

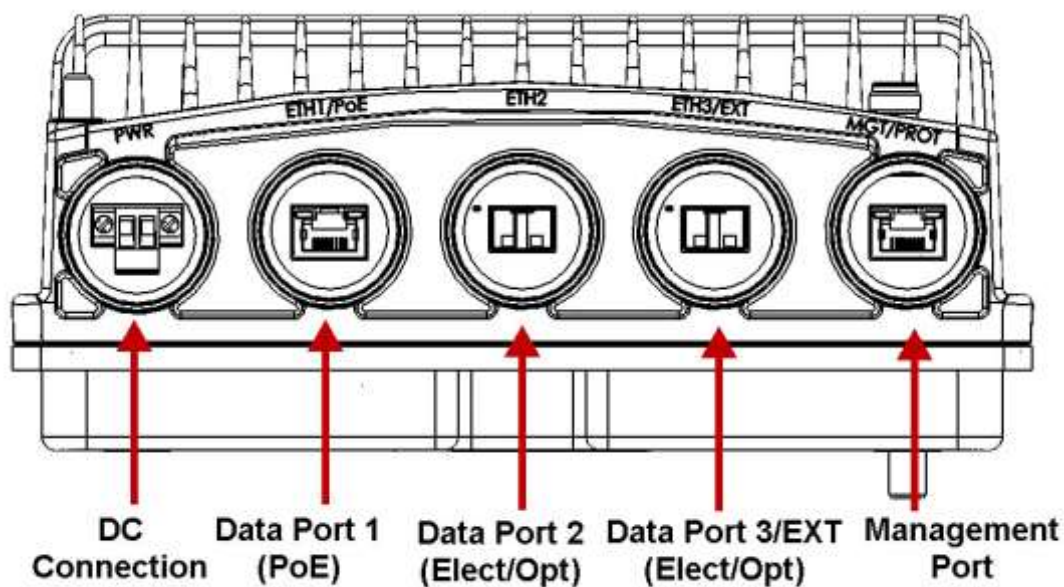

Figure 3: IP-20C Interfaces – Descriptive Labels

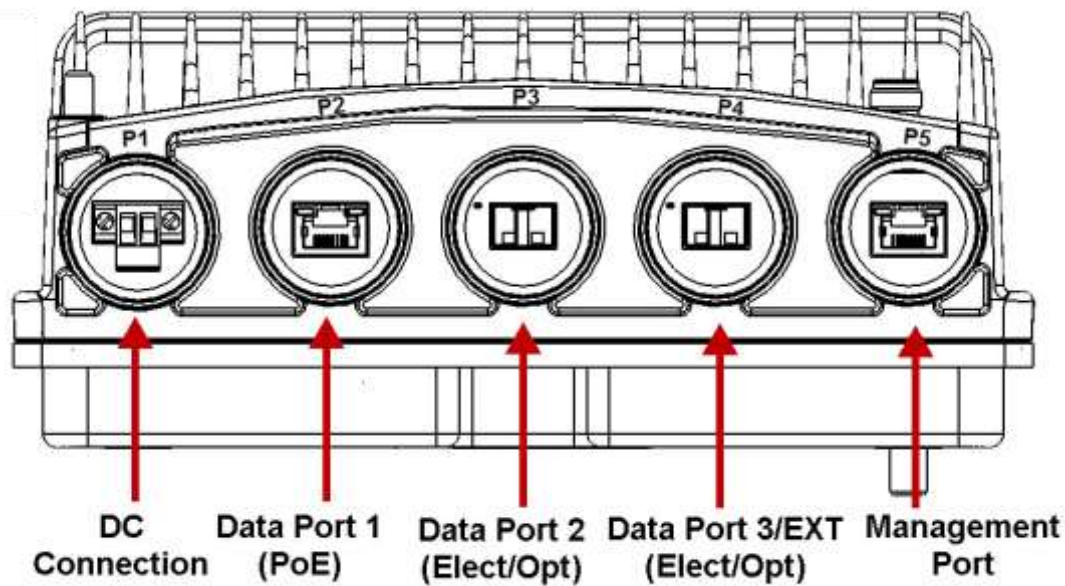

Figure 4: IP-20C Interfaces – Letter Labels

- Data Port 1 for GbE traffic:
 - Electric: 10/100/1000Base-T. Supports PoE.
- Data Port 2 for GbE traffic:
 - Electric: 10/100/1000Base-T
 - Optical: 1000Base-SX (or X-LX-ZX/XD)
- Data Port 3 for GbE traffic/expansion port:
 - Electric: 10/100/1000Base-T
 - Optical: 1000Base-SX (or X-LX-ZX/XD)
- Power interface (-48VDC)
- Management Port: 10/100Base-T
- 2 RF Interfaces: Standard interface per frequency band
- RSL interface: BNC connector
- Source sharing: TNC connector
- Grounding screw

The 2E2SX model includes two electrical traffic ports in a single gland, in addition to two optical ports, for a total of up to four available traffic ports. This model is interoperable with other IP-20C hardware models, and supports MIMO and all other advanced IP-20C features.

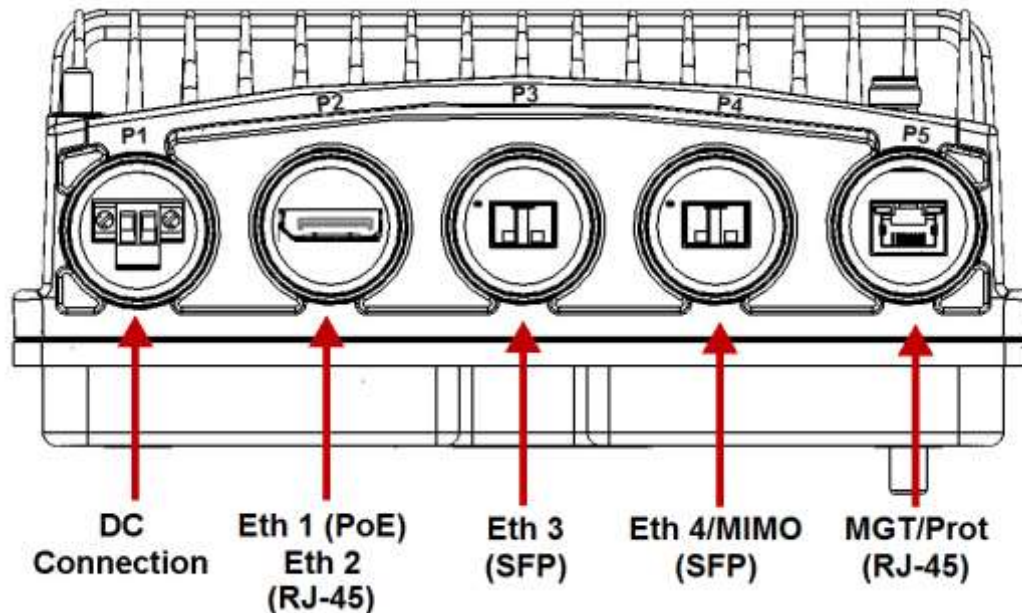

Figure 5: IP-20C Interfaces – 2E2SX Model

- Data Port 1 for GbE traffic (Eth 1):
 - 10/100/1000Base-T (RJ-45)
 - Supports PoE
 - Requires special splitter cable/adaptor
- Data Port 2 for GbE traffic (Eth 2):
 - 10/100/1000Base-T (RJ-45)
 - Requires special splitter cable/adaptor
- Data Port 3 for GbE traffic (Eth 3):
 - Electrical SFP: 1000Base-T
 - Optical SFP: 1000Base-X
- Data Port 4/EXT
 - SFP cage which supports SFP+ standard
 - 1G for traffic (Eth 4) or proprietary 10G connection when used as Extension port (automatically configured according to unit configuration)
- Power interface (-48VDC)
- Management Port: 10/100Base-T
- 2 RF Interfaces – Standard interface per frequency band
- RSL interface: BNC connector
- Source sharing: TNC connector
- Grounding screw

A special splitter is used to enable dual connection of the cables to a physical DisplayPort on the IP-20C 2E2SX. The splitter must be ordered separately, and is provided with its own gland. The following table gives the marketing model of the splitter and gland. For details, see *Using a Splitter Cable with P2 of a 2E2SX Hardware Model* on page 60.

Table 1: Ethernet Splitter Cable and Gland for Dual Ethernet Port

Marketing Model	Item Description
IP-20_Ethernet_Splitter_cable	CABLE,DP TO 2xRJ45F, 1.0M, WITH GLANDS, UV PROTECTED

2.1.2 Channel-Port Mapping to Polarization

Two transceiver chains and two diplexers are embedded in each IP-20C unit. In most cases, both diplexers are the same exact type. When the diplexers are the same type, radio ports 1 and 2 cover the exact same frequency range.

In the 6-11GHz frequency bands, where channelization and diplexers are relatively narrow, a single IP-20C unit might have to operate in two channels that are not covered by the same diplexer.

When this is required, the IP-20C can be ordered with two different diplexer types to cover two different channel ranges within the same frequency band.

An IP-20C with the same type of diplexer assembled on both transceiver chains has the following marketing model structure:

- **Example:** IP-20C-HP-6L-252A-**1W4**-H-ESX

In this example, **1W4** indicates that both transceivers cover channels 1 through 4.

An IP-20C with two different types of diplexers has the following marketing model structure:

- **Example:** IP-20C-HP-6L-252A-**1W27W8**-H-ESX

In this example, **1W27W8** indicates that channels 1 through 2 are covered by Port1, while channels 7 through 8 are covered by Port2.

An IP-20C assembly for this example would look as follows:

Table 2: Channel-Port Mapping, 1W27W8

Radio Port ID (EMS ID)	Channels Coverage
Port 2	Ch 7-8
Port 1	Ch 1-2

Figure 6: Channel Ranges

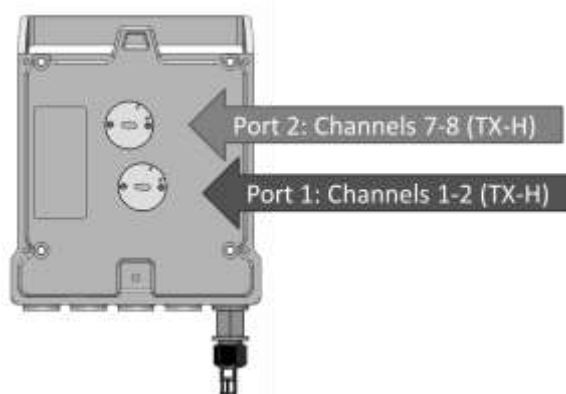

Note: The same orientation is maintained for TX-H and TX-L units.

When installing an IP-20C unit with two different diplexers in a Multicore 2+0 DP Direct Mount configuration, the V and H ports of the OMT are mechanically connected to Port 2 and 1 respectively.

This means that in the above example, V polarization is covered by channels 7 through 8 (Port 2) and H polarization is covered by channels 1 through 2 (Port 1).

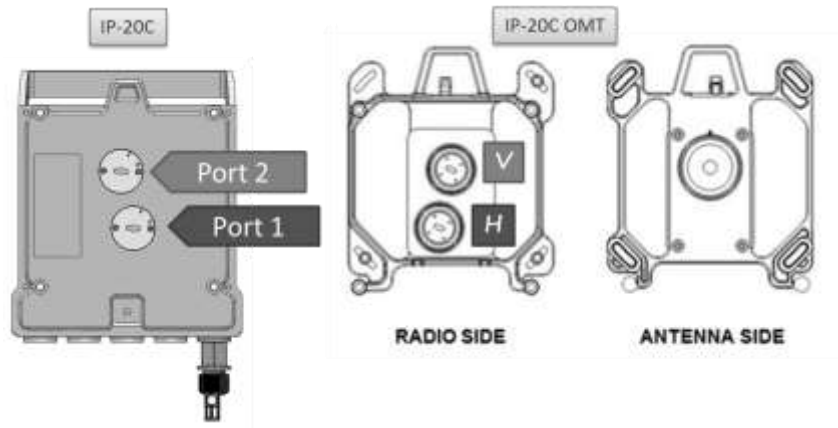

Figure 7: V and H Polarization

To assign the channels to different polarizations, a different system with a different marketing model should be ordered.

The following marketing model represents a system in which V polarization is covered by channels 1 through 2 (Port 2) and H polarization is covered by channels 7 through 8 (Port 1):

Figure 8: IP-20C-HP-6L-252A-7W81W2-H-ESX

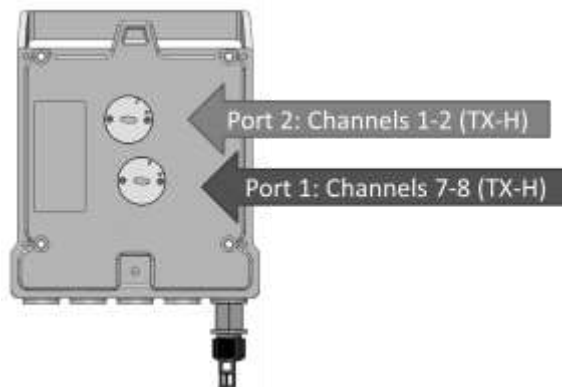

Table 3: Channel-Port Mapping, 7W81W2

Radio Port ID (EMS ID)	Channels Coverage
Port 2	Ch 1-2
Port 1	Ch 7-8

Please note that when selecting two operational channels that are not covered by the same diplexer, certain TX-TX separation and TX-RX separation criteria should be met.

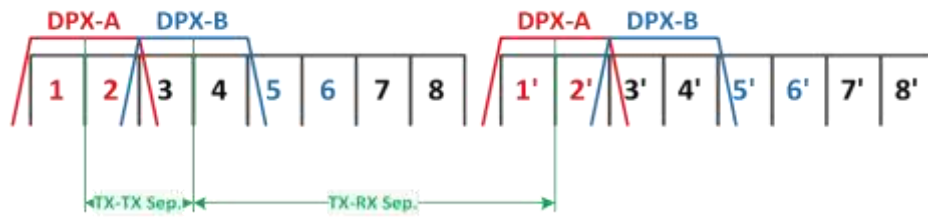

Figure 9: Separation Criteria when Working with Two Diplexer Types

Because diplexer coverage and channelization plans vary in different parts of the world for specific applications, please consult with Ceragon pre-sales representatives for support.

2.2 MultiCore Mediation Devices (MCMD)

The MultiCore Mediation Devices (MCMD) are designed to offer a simple and compact solution for a direct mount installation of the dual-carrier IP-20C on a standard RFU-C antenna.

IP-20C is equipped with two antenna ports, which mandates the use of the following MCMDs for direct mount connections. The specific MCMDs depend on the configuration.

The following describes some of the available MCMDs. For a full list of components, refer to *System Components* on page 23.

Note: MCMDs are not grounded. In order to add grounding, the MCMD can be connected to the IP-20C using a Grounding Jumper.

Table 4: MCMD Comparison

MCMD type	Functionality
Splitter	Combines the two carriers using the same polarization
OMT	Combines the two carriers on alternate polarizations (H,V)

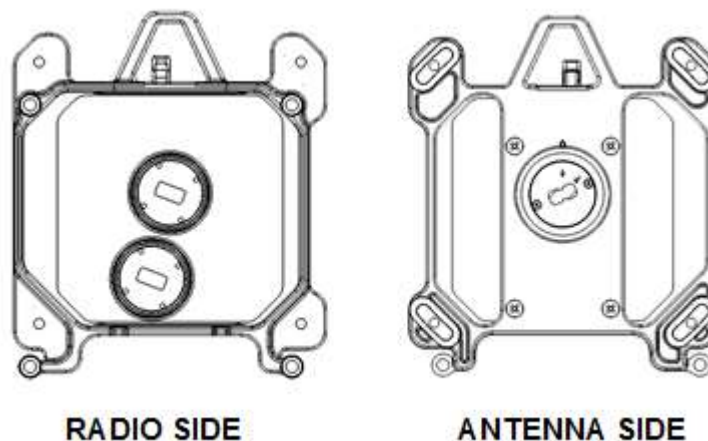

Figure 10: Splitter

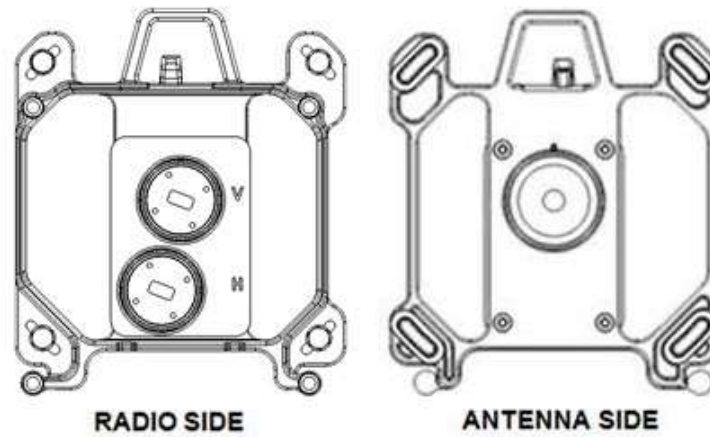

Figure 11: OMT

2.3 PoE Injector

The PoE injector is an outdoor unit which can be mounted on a wall, pole, or indoor rack.

Each PoE Injector kit includes the following items:

- PoE injector
- 2 DC power connectors

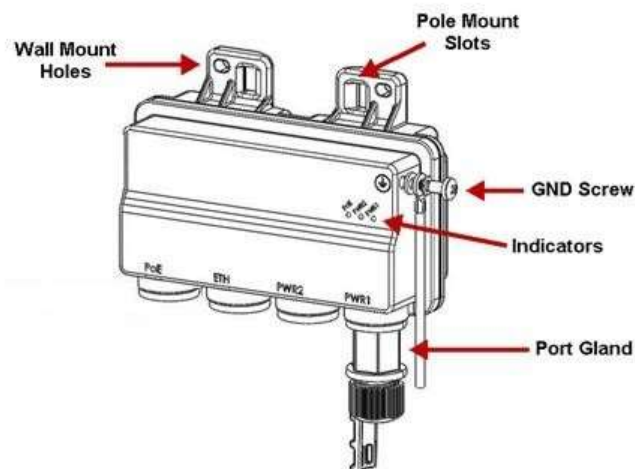

Figure 12: PoE Injector

Two models of the PoE Injector are available:

- **PoE_Inj_AO_2DC_24V_48V** – Includes two DC power ports with power input ranges of $-(18-60)V$ each.
- **PoE_Inj_AO** – Includes one DC power port (DC Power Port #1), with a power input range of $-(40-60)V$.

2.3.1 PoE Injector Interfaces

- Power-Over-Ethernet (PoE) Port
- GbE Data Port supporting 10/100/1000Base-T
- DC Power Port 1 -(18-60)V or -(40-60)V
- DC Power Port 2 -(18-60)V
- Grounding screw

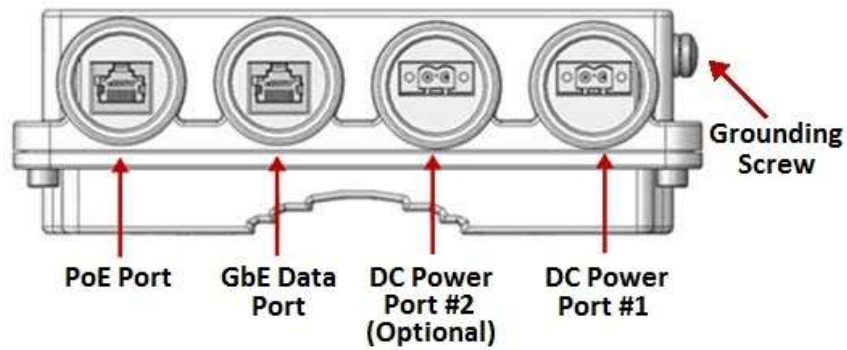

Figure 13: PoE Injector Ports

2.4 System Components

The following figures show the main components used in the IP-20C installation procedures.

Note! The availability of the installation components follows the IP-20C frequency rollout as stated in the published roadmap. The presence of a specific component in this manual does not indicate that it is available for ordering. Please consult with your respective pre-sales engineer for specific component availability.

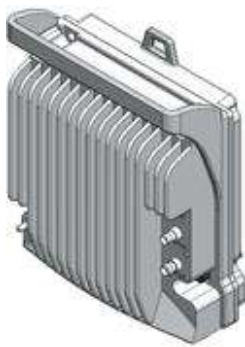

Figure 14: IP-20C

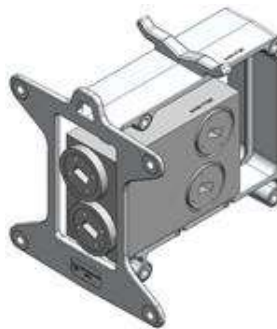

Figure 15: Dual Core Coupler/Splitter

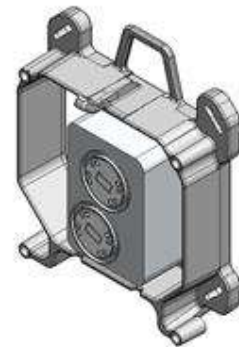

Figure 16: DC OMT



Figure 17: Remote Pole Mount



Figure 18: Remote Dual Pole Mount

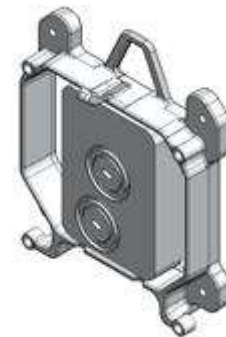

Figure 19: DC Splitter



Figure 20: Adaptor for 6-13 GHz

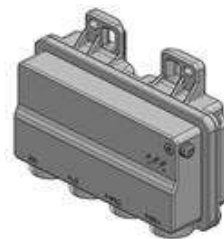

Figure 21: PoE Injector

2.5 Adaptors and Installation Kits

Table 5: Adaptors and Installation Kits, 6 GHz – 18 GHz

Description	6 GHz	7-8 GHz	10-11 GHz	13 GHz	15 GHz	18 GHz
IP-20C DUAL COUPLER KIT	IP-20C_DUAL_CPLR_kit_6G	IP-20C_DUAL_CPLR_kit_7-8G	IP-20C_DUAL_CPLR_kit_10-11G	IP-20C_DUAL_CPLR_kit_13G	IP-20C_DUAL_CPLR_kit_15G	IP-20C_DUAL_CPLR_kit_18G
IP-20C DUAL SPLITTER KIT	IP-20C_DUAL_SPLTR_kit_6G	IP-20C_DUAL_SPLTR_kit_7-8G	IP-20C_DUAL_SPLTR_kit_10-11G	IP-20C_DUAL_SPLTR_kit_13G	IP-20C_DUAL_SPLTR_kit_15G	IP-20C_DUAL_SPLTR_kit_18G
IP-20C SPLITTER KIT	IP-20C_SPLT_kit_6G	IP-20C_SPLT_kit_7-8G	IP-20C_SPLT_kit_10-11G	IP-20C_SPLT_kit_13G	IP-20C_SPLT_kit_15G	IP-20C_SPLT_kit_18G
IP-20C OMT KIT	IP-20C_OMT_kit_6G	IP-20C_OMT_kit_7-8G	IP-20C_OMT_kit_10-11G	IP-20C_OMT_kit_13G	IP-20C_OMT_kit_15G	IP-20C_OMT_kit_18G
IP-20C DUAL CORE KIT	IP-20C_DUAL_CORE_MD_kit_6G	IP-20C_DUAL_CORE_MD_kit_7-8G	IP-20C_DUAL_CORE_MD_kit_10-11G	IP-20C_DUAL_CORE_MD_kit_13G	IP-20C_DUAL_CORE_MD_kit_15G	IP-20C_DUAL_CORE_MD_kit_18G
IP-20C DC ADAPTOR REMOTE MOUNT KIT	IP-20C_6G_Rmt_Mnt_adpt	IP-20C_7-8G_Rmt_Mnt_adpt	IP-20C_10-11G_Rmt_Mnt_adpt	IP-20C_13G_Rmt_Mnt_adpt		
IP-20C DC REMOTE MOUNT OMT ADAPTOR KIT	IP-20C_RM_OMT_6G_adpt	IP-20C_RM_OMT_7-8G_adpt	IP-20C_RM_OMT_10-11G_adpt			

Table 6: Adaptors and Installation Kits, 23 GHz – 38 GHz

Description	23 GHz	26 GHz	28-31 GHz	32 GHz	38 GHz
IP-20C DUAL COUPLER KIT	IP-20C_DUAL_CPLR_kit_23G	IP-20C_DUAL_CPLR_kit_26G	IP-20C_DUAL_CPLR_kit_28G	IP-20C_DUAL_CPLR_kit_32G	IP-20C_DUAL_CPLR_kit_38G
IP-20C DUAL SPLITTER KIT	IP-20C_DUAL_SPLTR_kit_23G	IP-20C_DUAL_SPLTR_kit_26G	IP-20C_DUAL_SPLTR_kit_28G	IP-20C_DUAL_SPLTR_kit_32G	IP-20C_DUAL_SPLTR_kit_38G
IP-20C SPLITTER KIT	IP-20C_SPLT_kit_23G	IP-20C_SPLT_kit_26G	IP-20C_SPLT_kit_28G	IP-20C_SPLT_kit_32G	IP-20C_SPLT_kit_38G
IP-20C OMT KIT	IP-20C_OMT_kit_23G	IP-20C_OMT_kit_26G	IP-20C_OMT_kit_28G	IP-20C_OMT_kit_32G	IP-20C_OMT_kit_38G
IP-20C DUAL CORE KIT	IP-20C_DUAL_CORE_MD_kit_23G	IP-20C_DUAL_CORE_MD_kit_26G	IP-20C_DUAL_CORE_MD_kit_28G	IP-20C_DUAL_CORE_MD_kit_32G	IP-20C_DUAL_CORE_MD_kit_38G

Table 7: Adaptors and Installation Kits, Remote Mount - 6 GHz – 15 GHz

Remote Mount	6GHz	7-8GHz	10-11GHz	13GHz	15GHz
RFU-C REMOTE MOUNT KIT	RFU-C-PoleMount				
IP-20C DC REMOTE MOUNT KIT	IP-20C-Pole-Mount				
RFU-C ADAPTOR REMOTE MOUNT KIT	RFU-C6-RM_ADAPT	RFU-C7_8-RM_ADAPT	RFU-C10_11-RM_ADAPT	RFU-C13-RM_ADAPT	
RFU-C WG Kit	Flx-WG-4FT-6	Flx-WG-4FT-7_8	Flx-WG-4FT-10_11	Flx-WG-3FT-13	Flx-WG-3FT-15
RFU-C ADAPTOR TO FLEX WG (IMPERIAL)	ADPT_RFU-C6-	ADPT_RFU-C7_8-	ADPT_RFU-C10_11-	ADPT_RFU-C13-	ADPT_RFU-C15-

Remote Mount	6GHz	7-8GHz	10-11GHz	13GHz	15GHz
KIT	RM_mill	RM_mill	RM_mill	RM_mill	RM_mill

Table 8: Adaptors and Installation Kits, Remote Mount - 18 GHz – 42 GHz

Remote Mount	18GHz	23GHz	26GHz	28-31GHz	32GHz	38GHz	42GHz
RFU-C REMOTE MOUNT KIT	RFU-C-PoleMount						
IP-20C DC REMOTE MOUNT KIT	IP-20C-Pole-Mount						
RFU-C ADAPTOR REMOTE MOUNT KIT							
RFU-C WG Kit	Flx-WG-3FT-18-26			Flx-WG-3FT-28-38			Flx-WG-3FT-42
RFU-C ADAPTOR TO FLEX WG (IMPERIAL) KIT	ADPT_RFU-C18_26-RM_mill			ADPT_RFU-C28_38-RM_mill			

Table 9: 1500P Adaptors - 6GHz – 23 GHz

1500P Adaptors	6GHz	7-8GHz	10-11GHz	13GHz	15GHz	18GHz	23GHz
RFU-C-PHOSPHORUS DM ADAPTOR KIT			ADPT_RFU-C10_11-DM_1500P	ADPT_RFU-C13-DM_1500P	ADPT_RFU-C15-DM_1500P	ADPT_RFU-C18-DM_1500P	ADPT_RFU-C23-DM_1500P

Table 10: 1500P Adaptors - 26GHz – 42GHz

1500P Adaptors	26GHz	28-31GHz	32GHz	38GHz	42GHz
RFU-C-PHOSPHORUS DM ADAPTOR KIT	ADPT_RFU-C26-DM_1500P	ADPT_RFU-C28-DM_1500P	ADPT_RFU-C32-DM_1500P	ADPT_RFU-C38-DM_1500P	NA

Table 11: Imperial to mm Transitions – 6GHz – 15GHz

Imperial to mm Transitions	6GHz	7-8GHz	10-11GHz	13GHz	15GHz
RFU-C ADAPTOR KIT TO IMPERIAL ANT.	ADPT_RFU-C6-RM_Imp	ADPT_RFU-C7_8-RM_Imp	ADPT_RFU-C10_11-RM_Imp	ADPT_RFU-C13-RM_Imp	ADPT_RFU-C15-RM_Imp
RFU-C ADAPTOR KIT TO IMP WG	ADPT_RFU-C6-RM_mill	ADPT_RFU-C7_8-RM_mill	ADPT_RFU-C10_11-RM_mill	ADPT_RFU-C13-RM_mill	ADPT_RFU-C15-RM_mill

Table 12: Imperial to mm Transitions – 18GHz – 42GHz

Imperial to mm Transitions	18GHz	23GHz	26GHz	28-31GHz	32GHz	38GHz	42GHz
RFU-C ADAPTOR KIT TO IMPERIAL ANT.	ADPT_RFU-C18_26-RM_Imp			ADPT_RFU-C28_38-RM_Imp			NA
RFU-C ADAPTOR KIT TO IMP WG	ADPT_RFU-C18_26-RM_mill			ADPT_RFU-C28_38-RM_mill			NA

Table 13: Antenna Circ. Adapters for OMT – 6GHz – 18GHz

Note: This adapter is not required if the antenna is equipped with a circular feeder. Such antenna will have the following marketing model structure:

Am-size(ft)-freq-CIRC-mnf.

Antenna Circ. Adapters for OMT	6GHz	7-8GHz	10-11GHz	13GHz	15GHz	18GHz
CommScope	RFU-C6-OMT-INT-A	RFU-C7_8-OMT-INT-A	RFU-C10_11-OMT-INT-A	RFU-C13-OMT-INT-A	RFU-C15-OMT-INT-A	RFU-C18-OMT-INT-A
RFS 1-6FT	RFU-C6-OMT-INT-1_6FT-R	RFU-C7_8-OMT-INT-1_6FT-R	RFU-C10_11-OMT-INT-1_6FT-R	RFU-C13-OMT-INT-1_6FT-R	RFU-C15-OMT-INT-1_6FT-R	RFU-C18-OMT-INT-1_6FT-R
Radio Waves	RFU-C6L-OMT-INT-RW /RFU-C6H-OMT-INT-RW	RFU-C7_8-OMT-INT-RW	RFU-C10_11-OMT-INT-RW	RFU-C13-OMT-INT-RW	RFU-C15-OMT-INT-RW	RFU-C18-OMT-INT-RW
LEAX (Ceragon branding)	RFU-C6-OMT-INT-CR1	RFU-C7_8-OMT-INT-CR1	RFU-C10_11-OMT-INT-CR1	RFU-C13-OMT-INT-CR1	RFU-C15-OMT-INT-CR1	RFU-C18-OMT-INT-CR1
Xian Putian (Ceragon branding)	RFU-C6-OMT-INT-CR	RFU-C7_8-OMT-INT-CR	RFU-C10_11-OMT-INT-CR	RFU-C13-OMT-INT-CR	RFU-C15-OMT-INT-CR	RFU-C18-OMT-INT-CR
Xian Putian (OEM branding)	RFU-C6-OMT-INT-X	RFU-C7_8-OMT-INT-X	RFU-C10_11-OMT-INT-X	RFU-C13-OMT-INT-X	RFU-C15-OMT-INT-X	RFU-C18-OMT-INT-X

Table 14: Antenna Circ. Adapters for OMT – 23GHz – 42GHz

Note: This adapter is not required if the antenna is equipped with a circular feeder. Such antenna will have the following marketing model structure: Am-size(ft)-freq-CIRC-mnf.

Antenna Circ. Adapters for OMT	23GHz	26GHz	28GHz	32GHz	38GHz	42GHz
CommScope	RFU-C23-OMT-INT-A	RFU-C26-OMT-INT-A	RFU-C28-OMT-INT-A	RFU-C32-OMT-INT-A	RFU-C38-OMT-INT-A	RFU-C42-OMT-INT-A
RFS 1-6FT	RFU-C23-OMT-INT-1_6FT-R	RFU-C26-OMT-INT-1_6FT-R		RFU-C32-OMT-INT-1_6FT-R	RFU-C38-OMT-INT-1_6FT-R	NA
Radio Waves	RFU-C23-OMT-INT-RW	RFU-C26-OMT-INT-RW	RFU-C28-OMT-INT-RW	NA	RFU-C38-OMT-INT-RW	NA
RFU-C23-OMT-INT-CR1	RFU-C26-OMT-INT-CR1	RFU-C28-OMT-INT-CR1	RFU-C32-OMT-INT-CR1	RFU-C38-OMT-INT-CR1	RFU-C42-OMT-INT-CR1	RFU-C23-OMT-INT-CR1
Xian Putian (Ceragon branding)	RFU-C23-OMT-INT-CR	RFU-C26-OMT-INT-CR	RFU-C28-OMT-INT-CR	RFU-C32-OMT-INT-CR	RFU-C38-OMT-INT-CR	NA
Xian Putian (OEM branding)	RFU-C23-OMT-INT-X	RFU-C26-OMT-INT-X	RFU-C28-OMT-INT-X	RFU-C32-OMT-INT-X	RFU-C38-OMT-INT-X	NA

Table 15: PoE Injector

Marketing Model	Description
PoE_Inj_AO	PoE Injector all outdoor, -48VDC (Default offering)
PoE_Inj_AO_2DC_24V_48V	POE Injector all outdoor, redundant DC input, -48VDC
PoE_Inj_19inch_Rack_Mnt_kit	PoE Injector 19" Rack Mount Kit
PoE_Inj_ETSI_Rack_Mnt_kit	PoE Injector ETSI Rack Mount Kit

2.6 Antenna Connection

IP-20C can be mounted directly for all frequencies (6-42 GHz) using the following antenna types (for integrated antennas, specific antennas part numbers are required):

- CommScope: VHLP series
- RFS: SB/SC series
- Xian Putian: WTC/WTG series

For remote mount installations, the following Flexible Waveguide flanges should be used (millimetric). The same antenna type (integrated) as indicated above can be used (recommended).

Other antenna types using the flanges listed in the table below may also be used.

Table 16: Antenna Flanges

Frequency Band	Range (GHz)	Circ. WG Diameter	Rect. WG Flange Des.	Radio Side (Remote) Flange Des.	Flex WG Side A Flange Des.	Flex WG Side B Flange Des.	Antenna (Remote) Flange Des.
6(L/U) GHz	5.8-7.1					PDR70	UDR70
7/8 GHz	7.1-8.5	26 mm	WR112	UBR84	PBR84	PBR84	UBR84
10/11 GHz	10.0-11.7	18 mm	WR90	UBR100	PBR100	PBR100	UBR100
13 GHz	12.7-13.3	15 mm	WR75	UBR120	PBR120	PBR120	UBR120
15 GHz	14.5-15.4	13.5 mm	WR62	UBR140	PBR140	PBR140	UBR140
18 GHz	17.7-19.7	10.5 mm	WR42	UBR220	PBR220	PBR220	UBR220
23 GHz	21.2-23.6	9 mm					
26 GHz	24.5-26.6	8 mm					
28-31 GHz	27.3-29.5	7 mm	WR28	UBR320	PBR320	PBR320	UBR320
32 GHz	31.8-33.4	6.5 mm					
38 GHz	37.0-40.0	5.5 mm					
42 GHz	40.5-43.5	4.775 mm	WR22	UG383/U	UG383/U	UG383/U	UG383/U

If a different antenna type (CPR flange) is used, a flange adaptor is required. Please contact your Ceragon representative for details.

Note! Appropriate lubricant or grease can be applied to the screws that connect the IP-20C to the antenna interface.

2.7 Power Specifications

2.7.1 Electrical Requirements

- -48V DC Nominal
- Maximum current rating 1.5 A
- Maximum Cable length 300 meter
- Maximum cable size for PoE cable is 24 AWG, with maximum current up to 2A from the power source.

2.7.2 Important Notes!

- The unit must only be installed by service personnel.
- The unit must have a permanent connection to protective grounding.
- Data port 2, Data port 3, the Management port, and the TNC connector do not provide protection from over-voltages on telecommunication networks for host equipment users.
- The RSL interface connector is intended for technician use only.
- Disconnect device (circuit breaker) in the building installation:
 - Shall be readily accessible and incorporated external to the equipment.
 - The maximum rating of the overcurrent protection shall be up to 6 Amp.

2.8 Environmental Specifications

Operating: ETSI EN 300 019-1-4 Class 4.1

Temperature range for continuous operating temperature with high reliability:
-33°C (-27°F) to +55°C (131°F)

Temperature range for exceptional temperatures; tested successfully, with limited margins:

-45°C (-49°F) to +60°C (140°F)

Humidity: 5%RH to 100%RH

IEC529 IP66

Storage: ETSI EN 300 019-1-1 Class 1.2

Transportation: ETSI EN 300 019-1-2 Class 2.3

3. Cable Installation and Grounding

3.1 Minimum and Maximum Cable Diameter

To fit the gland, the outer cable diameter should be between 6-10 mm. This applies to all glands on both the IP-20C unit and the PoE Injector.

To fit the grounding clamp, the outer diameter of CAT5E Ethernet cables must be between 6-7.1mm.

3.2 Grounding the Cables

Cables must be grounded as follows:

- For fiber cables (see *Connecting an Optical Fiber Cable and SFP* on page 48), no grounding is required.
- For DC power cables (see *Connecting a DC Power Cable* on page 52), no grounding is required.
- For Ethernet cables, the shielded Ethernet cable (SF/UTP construction) must be grounded to the antenna tower at the top (next to the IP-20 unit), the entry to the indoor cabinet, and every 50m, using the kit CAT5E_gnd_kit.



Figure 22: Cable Grounding Kit

Table 17: Cable Grounding Kit

Marketing P/N	Description
CAT5E_gnd_kit	High speed GND KIT for CAT5e SF/UTP 5.9-7.1mm outdoor cable

To connect the grounding kit:

- 1 Strip the cable jacket.



- 2 Place the cable in the middle of the grounding bracket.



- 3 Close the grounding bracket around the cable.



- 4 Tighten the two screws to secure the grounding bracket around the cable.



- 5 Install the grounding lug on the grounding bar, or directly to the tower.



- 6 Tighten the grounding lug.

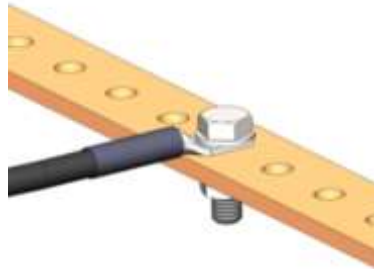

3.3 Grounding the IP-20C Unit

Required Tools

- Metric offset wrench key wrench #3
- Metric wrench 10mm

Procedure

- 7 On the front of each IP-20C unit, loosen the nut, plain washer, and serrated washer from the GND stud, using the metric offset hexagon key and the wrench.

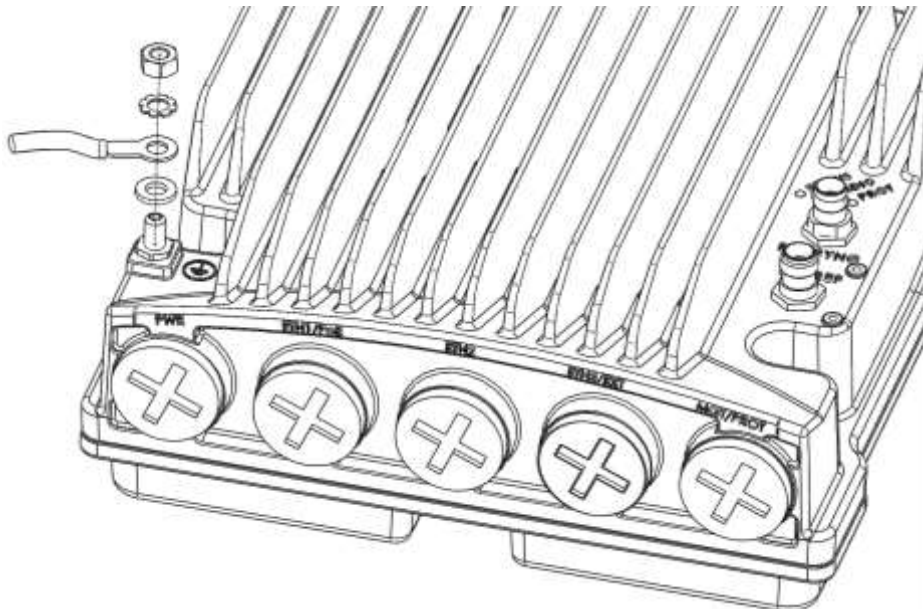

- 8 Place the cable lug (supplied with the IP-20C grounding kit) in place on the screw.
- 9 Secure the cable lug.
- 10 The second side of the GND cable should be connected to the main ground bar or terminal ground bar of the site.
- 11 Perform a resistance test between the 2 lugs of the GND cable. Verify that the result is 0-2 ohms.

Notes: The unit's earthing screw terminal shall be permanently connected to protective earth in a building installation in accordance with applicable national code and regulations by a service person.

A 2-pole circuit breaker, a branch circuit protector, suitably certified in accordance with applicable national code and regulations, rated maximum 20A, shall be installed for full power disconnection in a building installation.

Any outdoor antenna cable shield shall be permanently connected to protective earth in a building installation.

3.4 Power Source

The power cable must be plugged into the unit before turning on the external power.

When selecting a power source, the following must be considered:

DC power can be from -40 VDC to -60 VDC.

Recommended: Availability of a UPS (Uninterrupted Power Source), battery backup, and emergency power generator.

The power supply must have grounding points on the AC and DC sides.



Caution! The user power supply GND must be connected to the positive pole in the IP-20C power supply.
Any other connection may cause damage to the system!



Note! For the warranty to be honored, you must install the IP-20C in accordance with the instructions above.

3.5 Surge Protection

IP-20C includes built-in surge protection for its Ethernet and power interfaces. IP-20C's surge protection implementation complies with the standards set forth in the *Surge Protection* Requirements section of the IP-20C Technical Description, provided the Ethernet cables were prepared according to the instructions in *Connecting the Ethernet Cable* on page 55.

In areas in which severe lighting conditions are likely to occur, it is strongly recommended to add additional protection by placing lightning protectors on all electrical Ethernet cables, near the connection points with the IP-20C unit.

3.6 Available Cable Options

3.6.1 Fiber Optic Cables - Single Mode

Table 18: Fiber Optic Cables - Single Mode

Marketing P/N	Description
IP-20_FO_SM_LC2LC_ARM_7m	CABLE,FO,DUAL LC/LC,7M,SM,55mm OPEN END,M28 GLAND,ARMORED,OU
IP-20_FO_SM_LC2LC_ARM_15m	CABLE,FO,DUAL LC/LC,15M,SM,55mm OPEN END,M28 GLAND,ARMORED,O
IP-20_FO_SM_LC2LC_ARM_30m	CABLE,FO,DUAL LC/LC,30M,SM,55mm OPEN END,M28 GLAND,ARMORED,O
IP-20_FO_SM_LC2LC_ARM_50m	CABLE,FO,DUAL LC/LC,50M,SM,55mm OPEN END,M28 GLAND,ARMORED,O
IP-20_FO_SM_LC2LC_ARM_70m	CABLE,FO,DUAL LC/LC,70M,SM,55mm OPEN END,M28 GLAND,ARMORED,O
IP-20_FO_SM_LC2LC_ARM_80m	CABLE,FO,DUAL LC/LC,80M,SM,55mm OPEN END,M28 GLAND,ARMORED,O
IP-20_FO_SM_LC2LC_ARM_100m	CABLE,FO,DUAL LC/LC,100M,SM,55mm OPEN END,M28 GLAND,ARMORED
IP-20_FO_SM_LC2LC_ARM_150m	CABLE,FO,DUAL LC/LC,150M,SM,55mm OPEN END,M28 GLAND,ARMORED

3.6.2 Fiber Optic Cables - Multi Mode

Table 19: Fiber Optic Cables - Multi Mode

Marketing P/N	Description
IP-20_FO_MM_LC2LC_ARM_7m	CABLE,FO,DUAL LC/LC,7M,MM,55mm OPEN END,M28 GLAND,ARMORED,OU
IP-20_FO_MM_LC2LC_ARM_15m	CABLE,FO,DUAL LC/LC,15M,MM,55mm OPEN END,M28 GLAND,ARMORED,O
IP-20_FO_MM_LC2LC_ARM_20m	CABLE,FO,DUAL LC/LC,20M,MM,55mm OPEN END,M28 GLAND,ARMORED
IP-20_FO_MM_LC2LC_ARM_30m	CABLE,FO,DUAL LC/LC,30M,MM,55mm OPEN END,M28 GLAND,ARMORED,O
IP-20_FO_MM_LC2LC_ARM_50m	CABLE,FO,DUAL LC/LC,50M,MM,55mm OPEN END,M28 GLAND,ARMORED,O
IP-20_FO_MM_LC2LC_ARM_80m	CABLE,FO,DUAL LC/LC,80M,MM,55mm OPEN END,M28 GLAND,ARMORED,O
IP-20_FO_MM_LC2LC_ARM_100m	CABLE,FO,DUAL LC/LC,100M,MM,55mm OPEN END,M28

Marketing P/N	Description
	GLAND,ARMORED
IP-20_FO_MM_LC2LC_ARM_150m	CABLE,FO,DUAL LC/LC,150M,MM,55mm OPEN END,M28 GLAND,ARMORED
IP-20_FO_MM_LC2LC_ARM_200m	CABLE,FO,DUAL LC/LC,200M,MM,55mm OPEN END,M28 GLAND,ARMORED

3.6.3 DC Cable and Connector

Table 20: DC Cable and Connector

Marketing P/N	Description
Outdoor_DC_cbl_2x18AWG_drum	CABLE,305M,OUTDOOR_DC_CBL_2X18AWG_DRUM
IP-20C_DC_Conn	IP-20C_DC_Conn

3.6.4 Cables for MIMO Connections

Table 21: Cables for MIMO Connections

Marketing P/N	Description
DATA_SHRNG_KIT_5m	CABLE,SFP,4x4MIMO_DATA_SHARING_KIT_5M
DATA_SHRNG_KIT_10m	CABLE,SFP,4x4MIMO_DATA_SHARING_KIT_10M
DATA_SHRNG_KIT_20m	CABLE,SFP,4x4MIMO_DATA_SHARING_KIT_20M
DATA_SHRNG_KIT_30m	CABLE,SFP,4x4MIMO_DATA_SHARING_KIT_30M
SOURCE_SHARING_5M	Source_Sharing_5m
SOURCE_SHARING_10M	Source_Sharing_10m
SOURCE_SHARING_20M	Source_Sharing_20m
SOURCE_SHARING_30M	Source_Sharing_30m
IP-20_MIMO_Prot_mng_cbl_1m	IP-20C MIMO or Prot management cable 1m
IP-20_MIMO_Prot_mng_cbl_5m	IP-20C MIMO or Prot management cable 5m
IP-20_MIMO_Prot_mng_cbl_10m	IP-20C MIMO or Prot management cable 10m
IP-20_MIMO_Prot_mng_cbl_20m	IP-20C MIMO or Prot management cable 20m
IP-20_MIMO_Prot_mng_cbl_30m	IP-20C MIMO or Prot management cable 30m
IP-20_MIMO_Prot_mng_spltr	IP-20C MIMO or Prot management odu spltr

3.6.5 Ethernet Cable and Specifications

Table 22: Ethernet Cable and Specifications

Marketing P/N	Description
CAT5E_SFUTP_Outdoor_50m	CABLE,RJ45 TO RJ45 STR 50M,CAT-5E,ETHER,UV RES

Marketing P/N	Description
CAT5E_SFUTP_Outdoor_75m	CABLE,RJ45 TO RJ45 STR 75M,CAT-5E,ETHER,UV RES
CAT5E_SFUTP_Outdoor_305m_drum	CABLE,MATERIAL,CAT-5E,SFUTP,4X2X24AWG,UV RESISTANCE,305M
CAT5E_Arm_50m	CABLE,RJ45 TO RJ45 STR,50M,CAT-5E,M28 GLAN,ARM,UV RESISTANCE
CAT5E_Arm_70m	CAT5E_Arm_75mCABLE,RJ45 TO RJ45 STR,70M,CAT-5E,M28 GLAN,ARM,UV RESISTANCE
CAT5E_Arm_305m_drum	CABLE,MATERIAL,CAT-5E,FTP,4X2X24AWG,ARMORED,UV RESIST,305M

This cable has the following specifications:

- Suitable for:
 - Fast Ethernet
 - Gigabit Ethernet
 - PoE

Cable Design – The numbers in the figure below refer to the items listed beneath the figure.

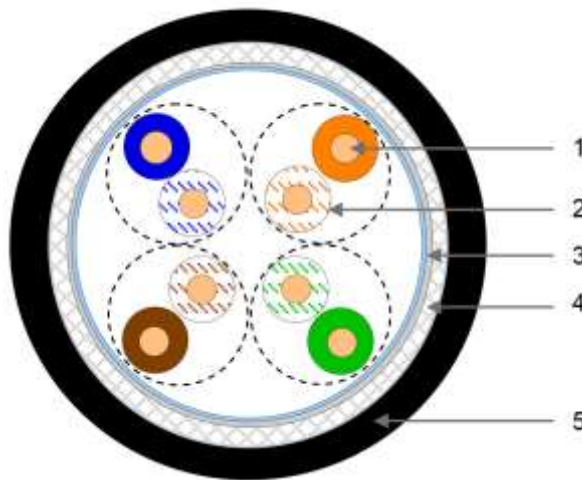

Figure 23: Cable Design

- [1] Conductor
- [2] Insulation
- [3] Screen: Alu/Pet foil. Alu outside
- [4] Tinned copper braid
- [5] Jacket

Table 23: Ethernet Cable Color Code

Pair	Wire A	Wire B
1	WHITE-blue	BLUE

2	WHITE-orange	ORANGE
3	WHITE-green	GREEN
4	WHITE-brown	BROWN

3.6.6 Outdoor Ethernet Cable Specifications

Table 24: Outdoor Ethernet Cable Specifications – Electrical Requirements

Cable type	CAT-5e SFUTP , 4 pairs, according to ANSI/TIA/EIA-568-B-2	
Wire gage	24 AWG	
Stranding	Solid	
Voltage rating	70V	
Shielding	Tinned copper Braid (Coverage: >=80%) + Aluminum Foil	
Pinout	RJ45,P1	RJ45,P2
	1 ————	1
	2 ————	2
	3 ————	3
	6 ————	6
	4 ————	4
	5 ————	5
	7 ————	7
	8 ————	8
	DRAIN WIRE + SHIELD	
	SHELL	SHEEL

Table 25: Outdoor Ethernet Cable Specifications – Mechanical/ Environmental Requirements

Jacket	UV resistant
Outer diameter	6-7.1 mm (in order to be compatible with the grounding clamp, CAT5E_gnd_kit)
Operating and Storage temperature range	-40°C - 85°C
Flammability rating	According to UL-1581 VW1, IEC 60332-1
RoHS	According to Directive/2002/95/EC

3.6.7 Outdoor DC Cable Specifications

Table 26: Outdoor DC Cable Specifications – Electrical Requirements

Cable type	2 tinned copper wires
Wire gage	18 AWG (for <100m installations) 12 AWG (for >100m installations)
Stranding	stranded
Voltage rating	600V
Spark test	4KV
Dielectric strength	2KV AC min

Table 27: Outdoor DC Cable Specifications – Mechanical/ Environmental Requirements

Jacket	UV resistant
Outer diameter	7-10 mm
Operating and Storage temperature range	-40°C - 85°C
Flammability rating	According to UL-1581 VW1, IEC 60332-1
RoHS	According to Directive/2002/95/EC

3.7 Securing the Cables

All cables should be secured at every meter on-site using either a T-Rups kit, P/N Outdoor Ties (SI-0027-0) or cable clamps. When using the T-Rups kit, take special care to apply the proper amount of force in order to avoid damage to the cable. This is especially important for optical (SFP) cables.

The following cable clamps are available:

Table 28: Cable Clamps

Part Number	Marketing Model	Item Description
SI-1229-0	Fiber_clamp_2cbl_4.0-7.0mm	DUAL FEADER CLAMP FOR 4.0-7.0mm CABLE 2 WAY.
SI-1230-0	Fiber_clamp_4cbl_4.0-7.0mm	DUAL FEADER CLAMP FOR 4.0-7.0mm CABLE 4 WAY.
SI-1231-0	Fiber_clamp_6cbl_4.0-7.0mm	DUAL FEADER CLAMP FOR 4.0-7.0mm CABLE 6 WAY.

3.8 Special Instructions for use of Glands

Note: Each IP-20C unit is supplied with two glands. If additional glands are required, they must be ordered separately, in kits of five glands each.

Table 29: Glands Kit

Marketing Model	Marketing Description
IP-20_Glands_kit	IP-20_Glands_x5_kit

In addition, gland caps can be ordered to protect the cable and connector from damage when elevating the cable and gland to the radio unit. See Step 5 in Section 3.8.1, *General Installation Procedure*. Gland caps are ordered separately, in kits of 10 caps each.

Table 30: Gland Caps

Marketing Model	Marketing Description
Cable_Prot_10Caps_kit	Cable protective caps kit 10 pcs, IP-20C/S/E

In order to remove the plastic plugs for the unit, you can use the flange of supplied glands to disconnect them. See figures below.

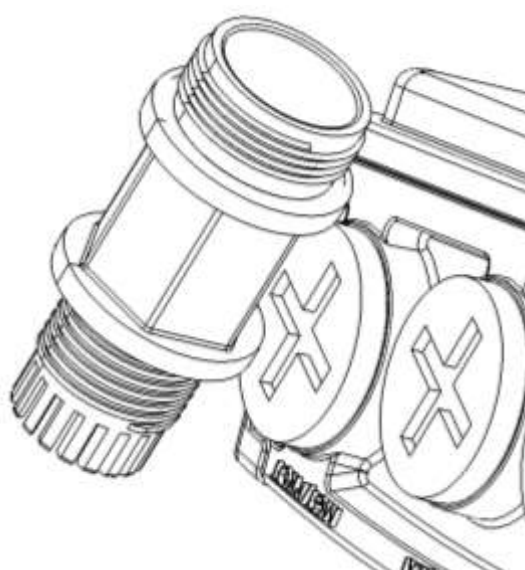

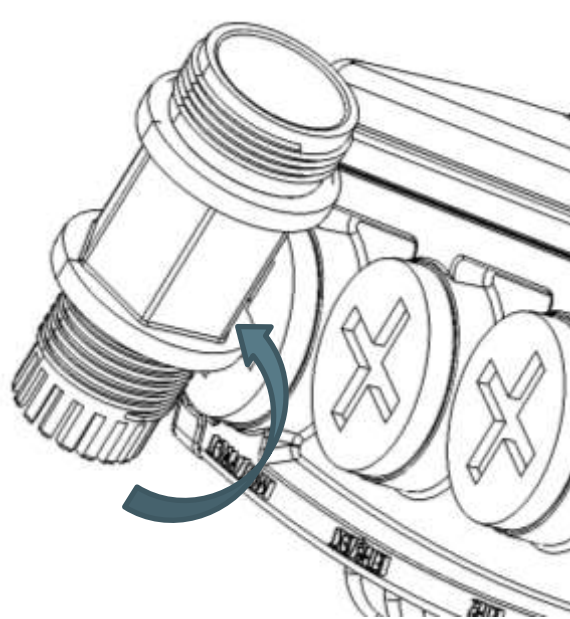

3.8.1 General Installation Procedure

This procedure applies to all cable types, and explains how to install the cables using long glands. The gland is supplied assembled.

- 1 Before inserting a cable, you must disassemble the gland cap and gland rubber from the gland body.

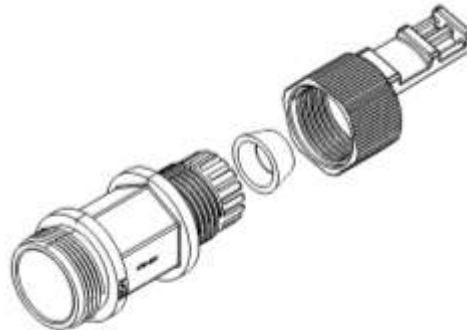

- 2 Slide the gland cap into the cable.

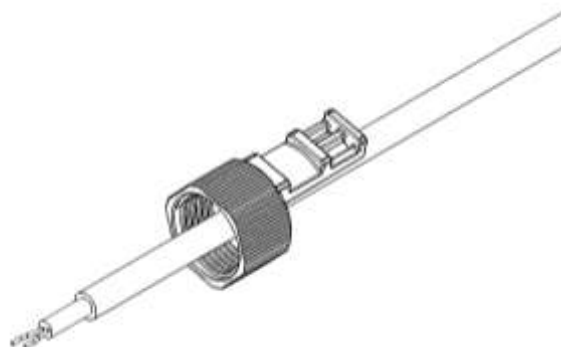

- 3 Slide the gland rubber into the cable.

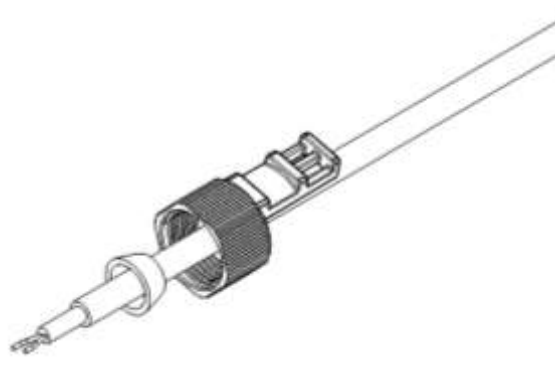

- 4 Slide the cable into the body of the gland. If you are using a gland cap (see Step 5), make sure to leave enough space for the gland cap to fit into the gland without disturbing the cable.

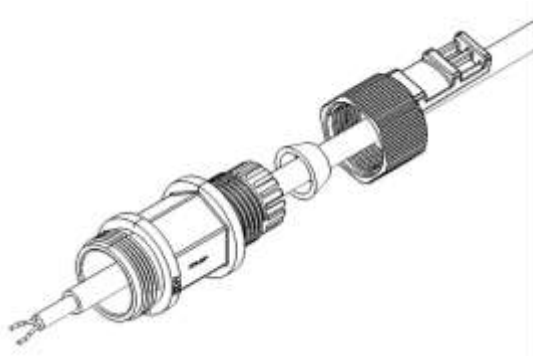

- 5 Optionally, after securing the cable into the body of the gland, you can close the other side of the gland with an M28 gland cap. The gland cap protects the cable and connector from damage when elevating the cable and gland to the radio unit.

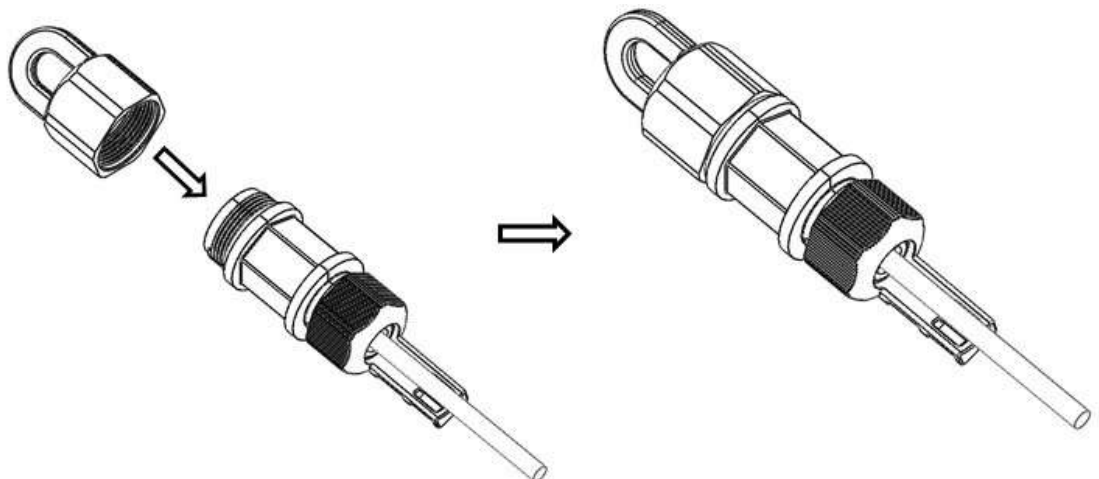

- 6 The M28 gland cap has a hook on top. After attaching the gland cap to the gland, you can connect a rope to the hook and use this to lift the gland and cable up to the radio unit. Before screwing the gland into the radio unit, you must remove the gland cap.

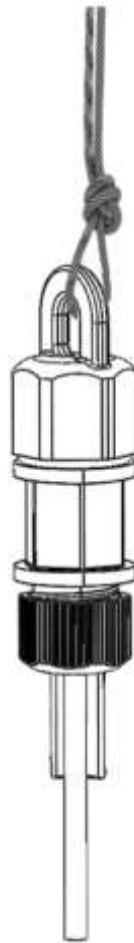

- 7 If you used an M28 gland cap to close the gland when raising the gland and cable to the radio unit, remove the gland cap from the gland at this point by unscrewing the cap.
- 8 Connect the cable to the port.
- 9 Screw the gland into the radio unit until there is full contact between the gland and the radio unit.

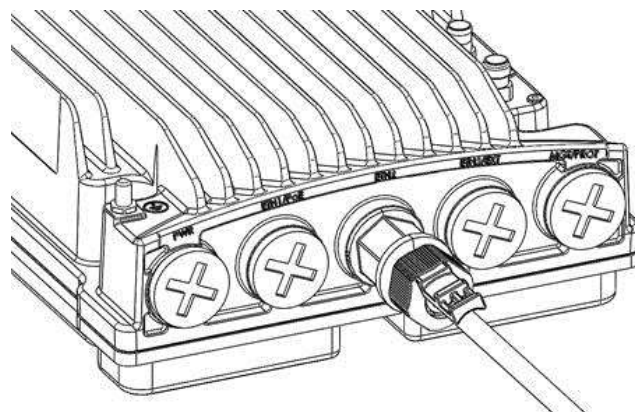

Important Note! Before tightening the gland, make sure the gland is aligned with the tapped hole in the unit. Tightening the gland at an angle can ruin the thread on the gland and prevent proper sealing of the interface.

- 10 Insert the main part of the gland into the thread in the radio body and tighten until there is full contact and the gasket is fully contained between the gland and the radio and cannot be seen. Tighten the gland gently and make sure there is no resistance. If there is resistance, stop immediately, and thread out the gland. Verify that the gland thread is not damaged and tighten the gland again.

Important Note! Pay attention that the gland rubber is properly located and not damaged during the tightening of the gland cap.
If the gland thread is damaged do not use it!



- 11 Tighten the rear portion of the gland onto the main part of the gland and make sure that the main part of the gland does not have an additional swivel after the rear portion is secured.

Note: If the main portion of the gland is rotated while the rear portion is seizing the cable, this may ruin the cable connector.

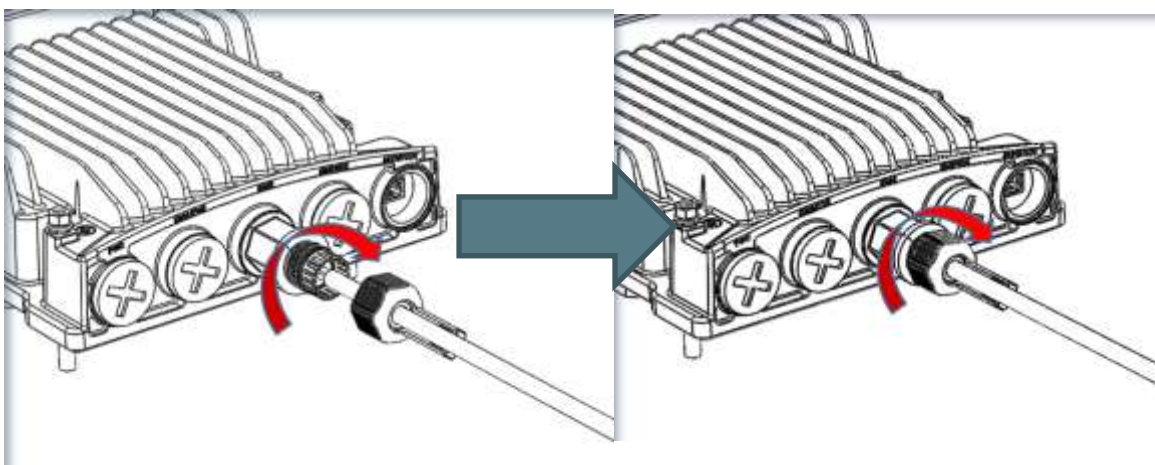
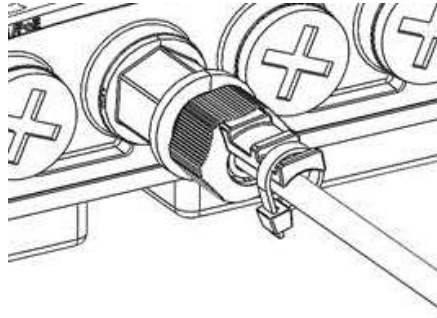

Figure 24: Tightening the Front Portion of the Gland

Figure 25: Tightening the Rear Portion of the Gland

12 Secure the cable to the lip of the gland using a tie wrap.



3.9 Connecting an Optical Fiber Cable and SFP

To connect an optical fiber cable and the SFP transceiver:

- 1 Use a pre-assembled cable.

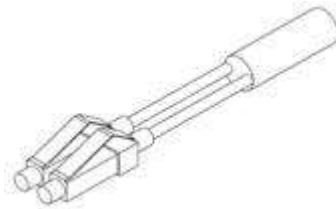

- 2 Split the connector into two separate LC connectors (one for each fiber).



- 3 Remove the gland cap and rubber from the gland body.

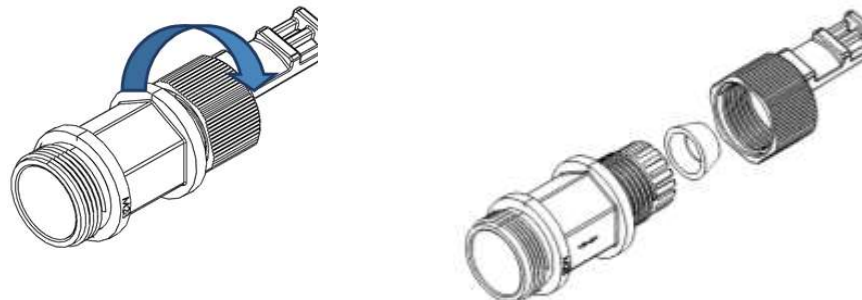

- 4 Slide the gland cap into the cable.
- 5 Slide the rubber into the cable.

- 6 Insert the fibers with the connectors one by one into the cable gland.

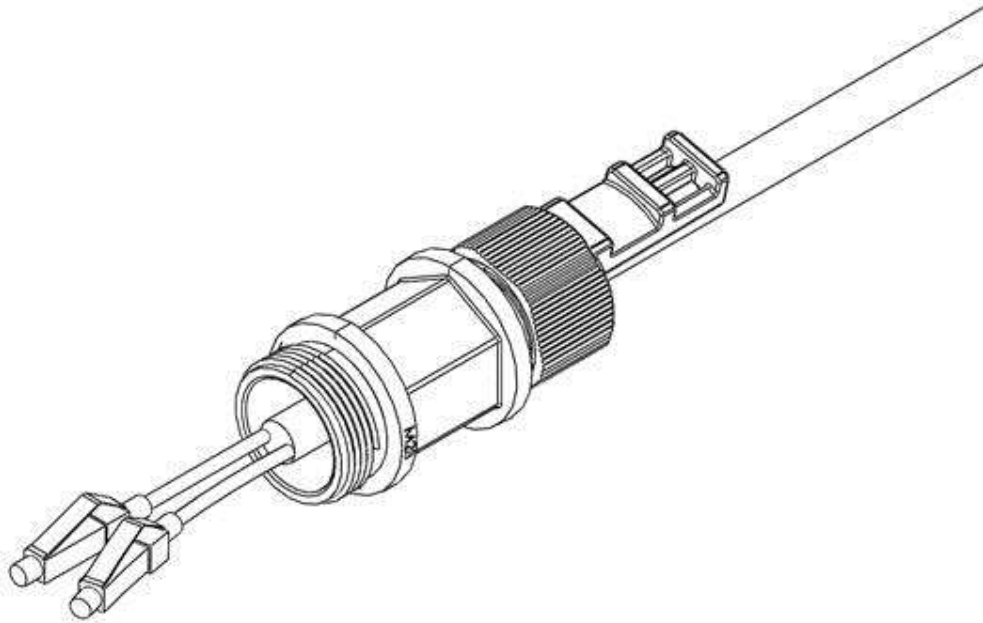

- 7 Secure the cable to the lip of the gland using a tie wrap.

Important Note! If you are raising the cable to a radio unit on a tower, this step is crucial to prevent the cable from slipping from the gland, which could damage the connector.

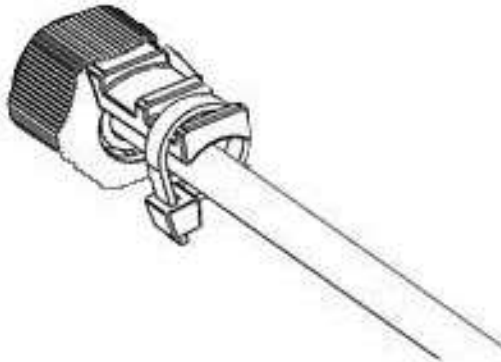

- 8 Connect the fibers to the SFP transceiver. Listen for the “click” to ensure that they are fully inserted.

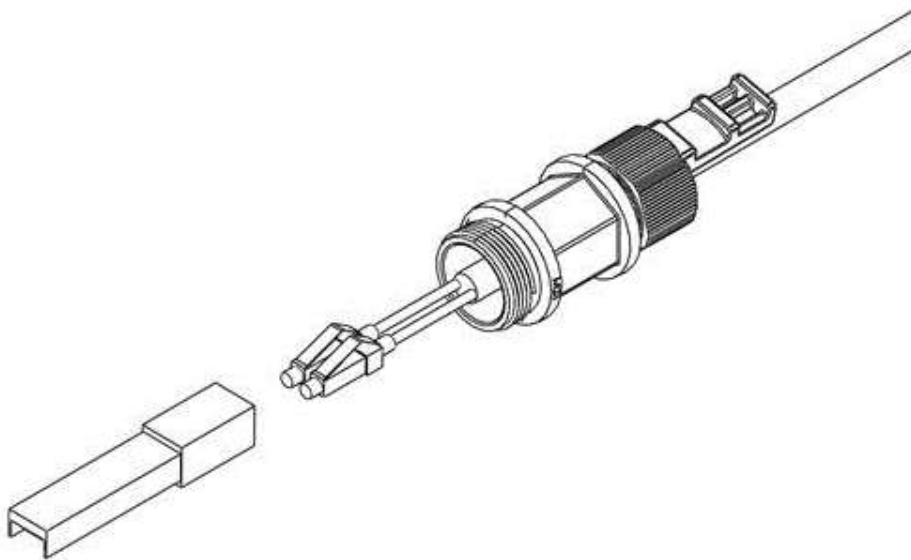

- 9 Remove the tie wrap securing the cable to the gland.

Note: A new tie wrap must be used to secure the cable to the gland at the end of the procedure, as described in Step 13.

- 10 Connect the connector into the IP-20C connector.

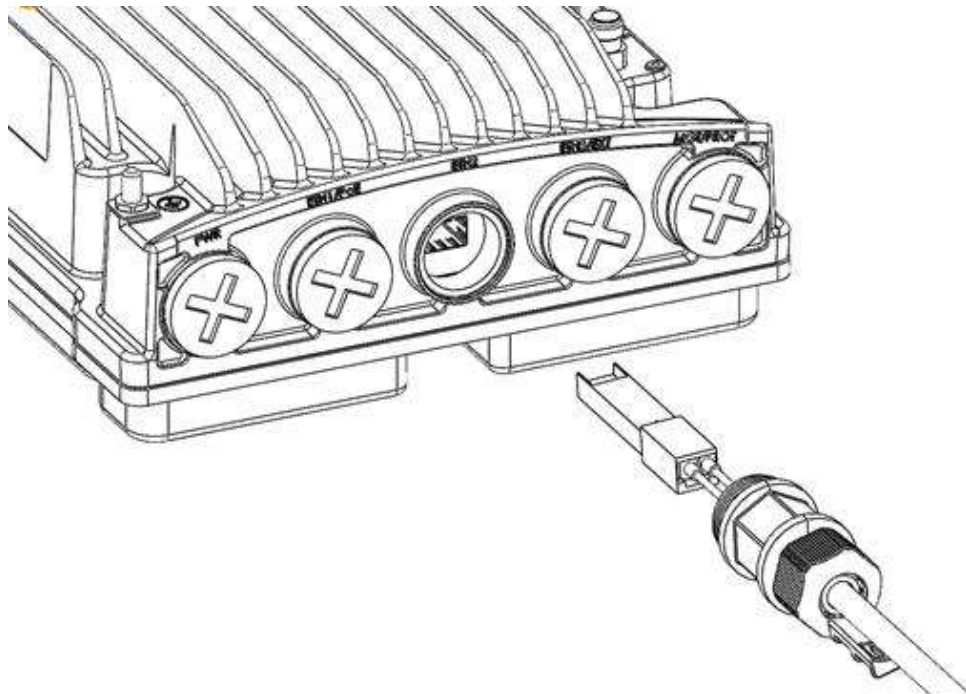

- 11 Tighten the gland to the radio unit until there is full contact between the gland and the radio unit.

12 Tighten the gland cap.

Important Note! Before tightening the gland, make sure the gland is aligned with the tapped hole in the unit.

Tightening the gland at an angle can ruin the thread on the gland and prevent proper sealing of the interface. Tighten the gland gently and make sure there is no resistance. If there is resistance, stop immediately, thread out the gland, and verify that the gland threads are not damaged. Then, tighten the gland again.

If the gland thread is damaged do not use it!

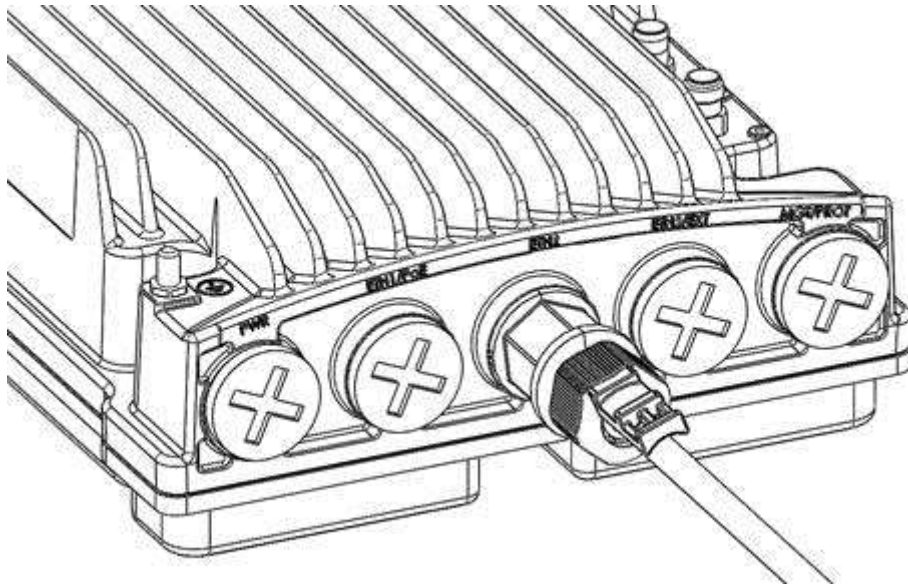

13 Secure the cable to the gland using a tie wrap.

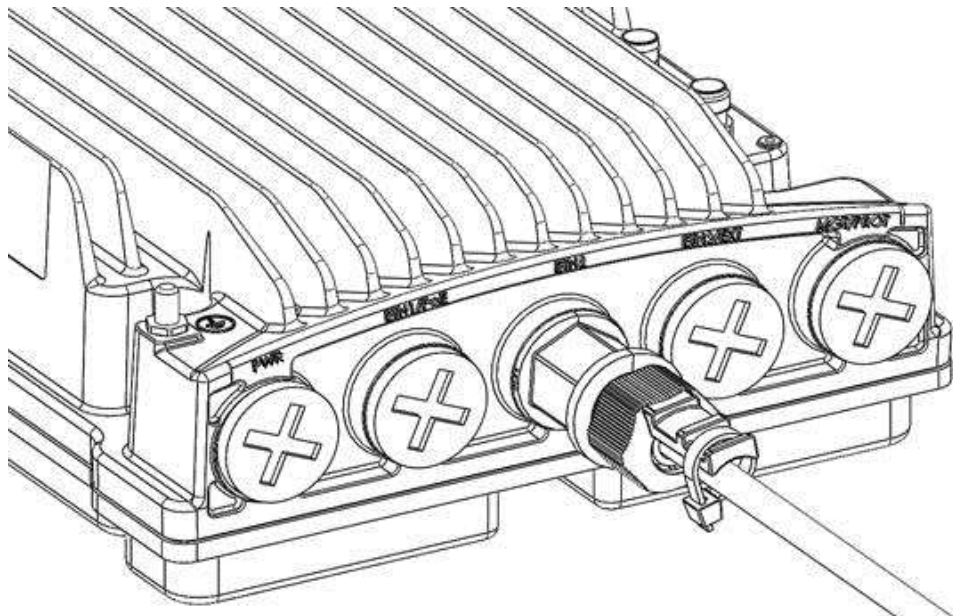

3.10 Connecting a DC Power Cable

Note: The DC power cable and connector must be ordered separately. See *DC Cable and Connector* on page 38.

To connect a DC power cable:

- 1 Strip off 45 mm from the cable jacket.
- 2 Expose 10 mm at the edge of each of the two wires.

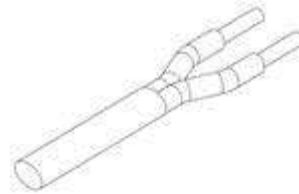

- 3 Insert the power cable into the gland.

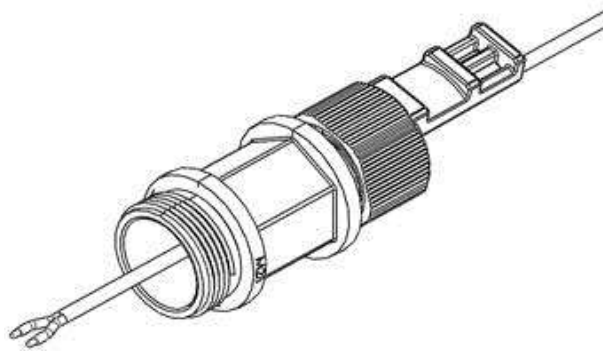

- 4 Insert the power cable wires into the power connector.
- 5 Insert the power cable wires into the power connector. Match "+" to the 0V wire and "-" to the -48V wire.

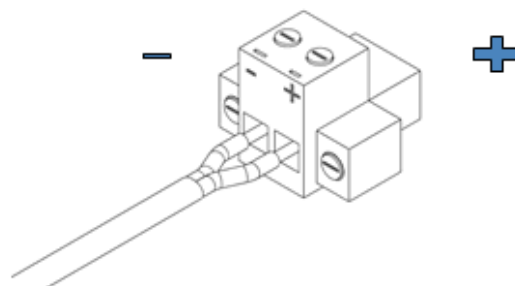

6 Tighten the two top screws.

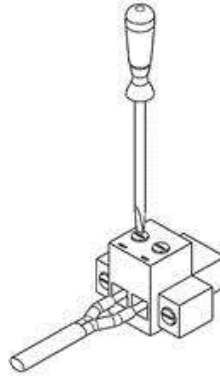

7 Plug the power cable with connector into the IP-20C power connector.

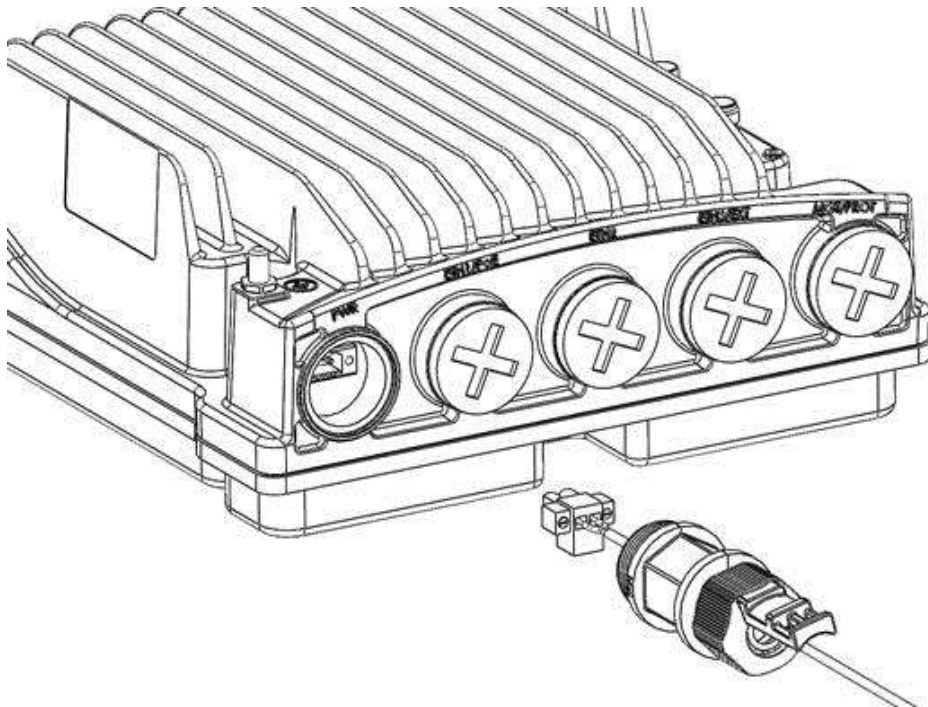

8 Tighten the two front screws.

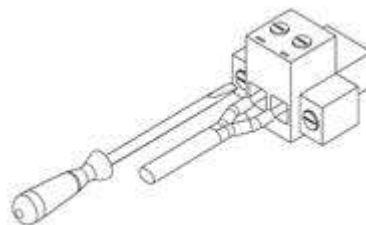

9 Screw the gland into the radio unit

Important Note! Before tightening the gland, make sure the gland is even with the cover. Tighten the gland gently and make sure there is no resistance. If there is resistance, stop immediately and verify that the gland is not being inserted at an angle. Tightening the gland at an angle can ruin the thread on the gland and prevent proper sealing of the interface.

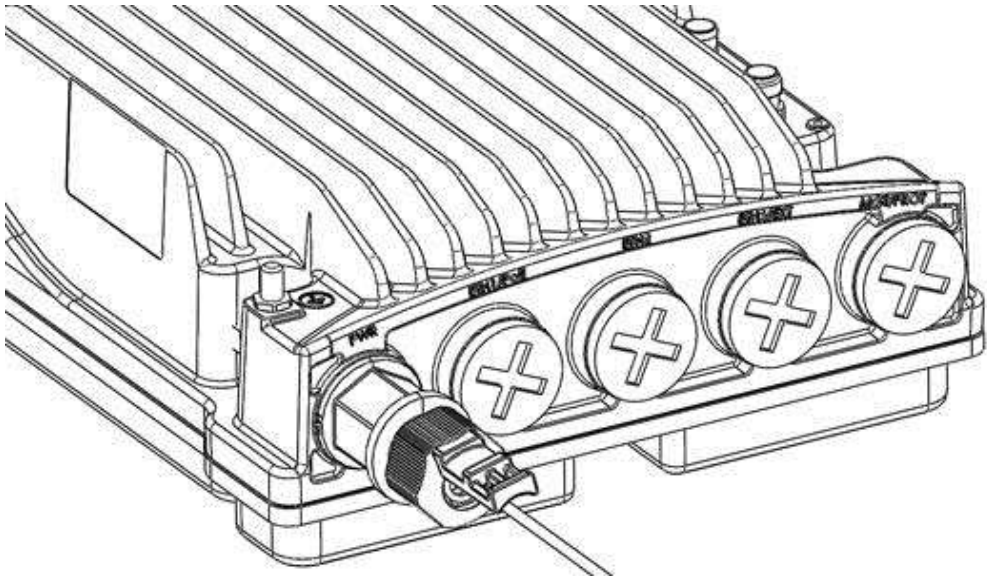

10 Tighten the gland cap.

11 Secure the cable to the gland with a tie wrap.

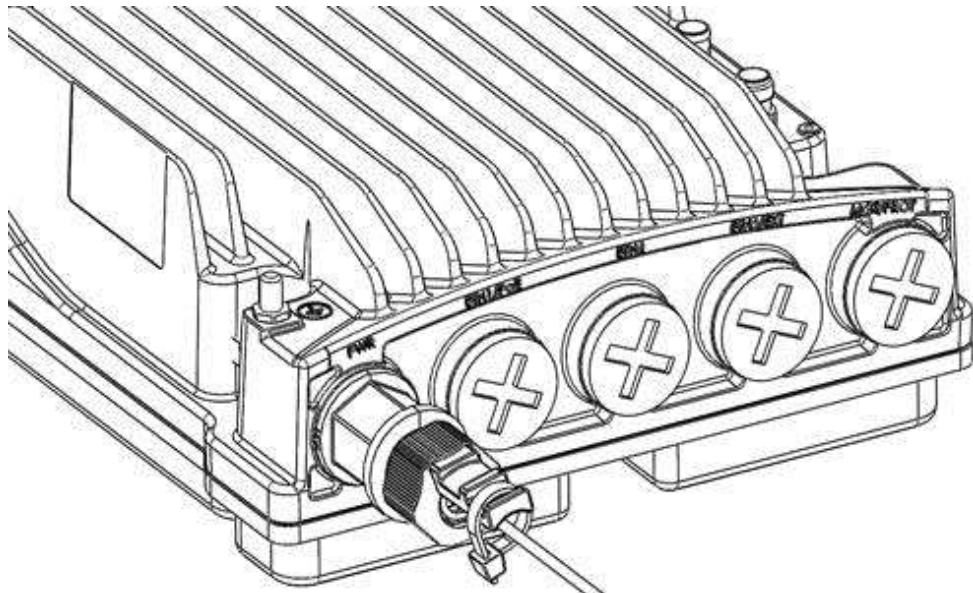

3.11 Connecting the Ethernet Cable

If you need to assemble the Ethernet cable, follow the instructions in section 3.11.1, *Preparing the Ethernet Cable and Plug-in Field*, then proceed to section 3.11.3, *Connection of Ethernet Cable to IP-20C*.

If you are using a pre-assembled Ethernet cable, follow the instructions in section 3.11.2, *Preparing the Ethernet Cable Already Assembled*, then proceed to section 3.11.3, *Connection of Ethernet Cable to IP-20C*.

Note: To ensure proper grounding and connectivity, it is recommended to use pre-assembled Ethernet cables.

3.11.1 Preparing the Ethernet Cable and Plug-in Field

Important Note! To ensure proper grounding, the RJ-45 plug must be shielded, with a crimping tail.



Table 31: Materials for Preparing Ethernet Data Cables

Marketing P/N	Description
CAT5E_SFUTP_Outdoor_50m	CABLE,RJ45 TO RJ45 STR 50M,CAT-5E,ETHER,UV RES
CAT5E_SFUTP_Outdoor_75m	CABLE,RJ45 TO RJ45 STR 75M,CAT-5E,ETHER,UV RES
CAT5E_SFUTP_Outdoor_100m_drum	CABLE,MATERIAL,CAT-5E,SFUTP,4X2X24AWG,UV RESISTANCE,100M
CAT5E_SFUTP_Outdoor_305m_drum	CABLE,MATERIAL,CAT-5E,SFUTP,4X2X24AWG,UV RESISTANCE,305M
IP-20_Glands_kit	KIT 5pcs of M28 GLAND (AA-0597-0)
CAT5E_gnd_kit	High speed GND KIT for CAT5e SF/UTP 5.9-7.1mm outdoor cable
GBE_connector_kit	RJ45 CAT5E CONNECTORS AND BOOTS KIT (package of 10 connectors)

To prepare the Ethernet cable and plug-in field:

- 1 Prepare the gland and insert the cable, as described in *General Installation Procedure* on page 43.
- 2 Strip off approximately 45 mm of the outer insulation jacket from the CAT5E cable.

- 3 Do not strip off the end of the cable shield, but rather, twist the shield to form a braid.



- 4 Roll back the foil shield insulation and wrap the drain wire around the foil. Do not remove any insulation from the conductors.
- 5 Align the colored wires.

Note: Cord colors should be matched to the same pins on both ends of the cable.

- 6 Trim all wires to the same length. About 12 mm on the left should be exposed from the inner sheath.
- 7 Separate the wires and place the twisted shield between the separated wires.



- 8 Insert the wires into the RJ45 plug. Verify that each wire is fully inserted into the front of the RJ45 plug and in the correct order, according to the pinouts shown in Section 3.6.6, *Outdoor Ethernet Cable Specifications*. The sheath of the Ethernet cable should extend into the plug by about 13 mm and held in place by the crimp.
- 9 Extend the cable jacket with the shield into the connector about 5 mm for strain relief and shielding connection.

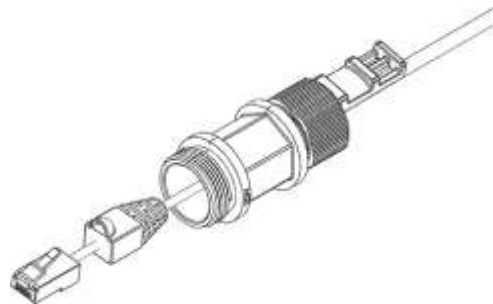

- 10 Wrap the twisted braid firmly around the cable jacket and let the crimping tail of the RJ45 plug envelop it.

Important Note! To ensure proper grounding, it is essential that the twisted braid be firmly connected to the RJ45 plug.



Twisted Braid Enveloped by Crimping Tail

- 11 Crimp the RJ45 plug with the crimp tool. Make sure the twisted shield is crimped firmly to the RJ45 plug.



- 12 Verify that the wires ended up the correct order and that the wires extend to the front of the RJ45 plug and make good contact with the metal contacts in the RJ45 plug.
- 13 Push back the CAT5E plug cover on the connector plug.

Note: It is recommended that the newly prepared cable be tested with a Cable Analyzer such as the FLUKE DTX-1800 (or the equivalent), to make sure the cable complies with ANSI/TIA/EIA-568-B-2. Make sure to verify both connectivity and grounding continuity at both ends of the cable.

3.11.2 Preparing the Ethernet Cable Already Assembled

To prepare the Ethernet cable already assembled:

- 1 Release the gland cap and the gland rubber slightly.

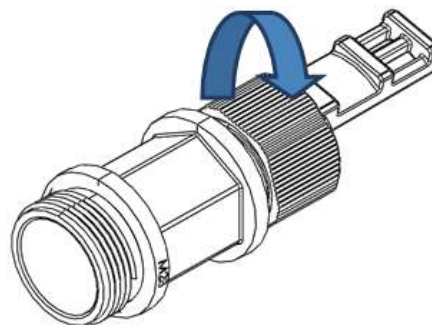

- 2 Insert the CAT5E cable into the gland cap and into the rubber gland.

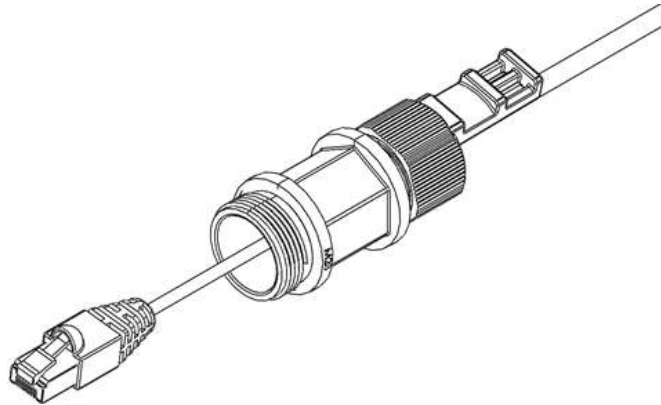

- 3 Insert the CAT5E cable into the gland body.

3.11.3 Connection of Ethernet Cable to IP-20C

To connect the Ethernet cable to the IP-20C:

- 1 Remove the relevant cap from the IP-20C radio. You can use the side of the gland to unscrew the cap.

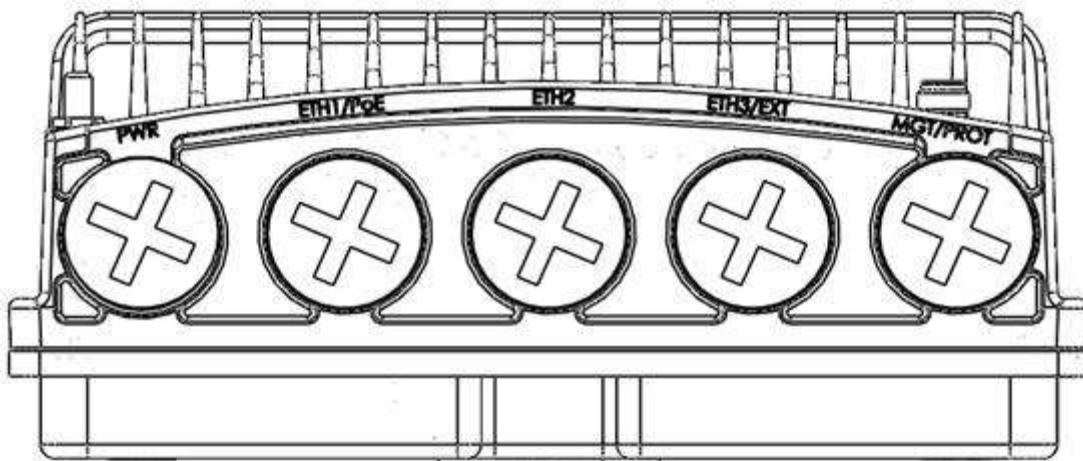

- 2 Connect the CAT5E cable to the IP-20C.

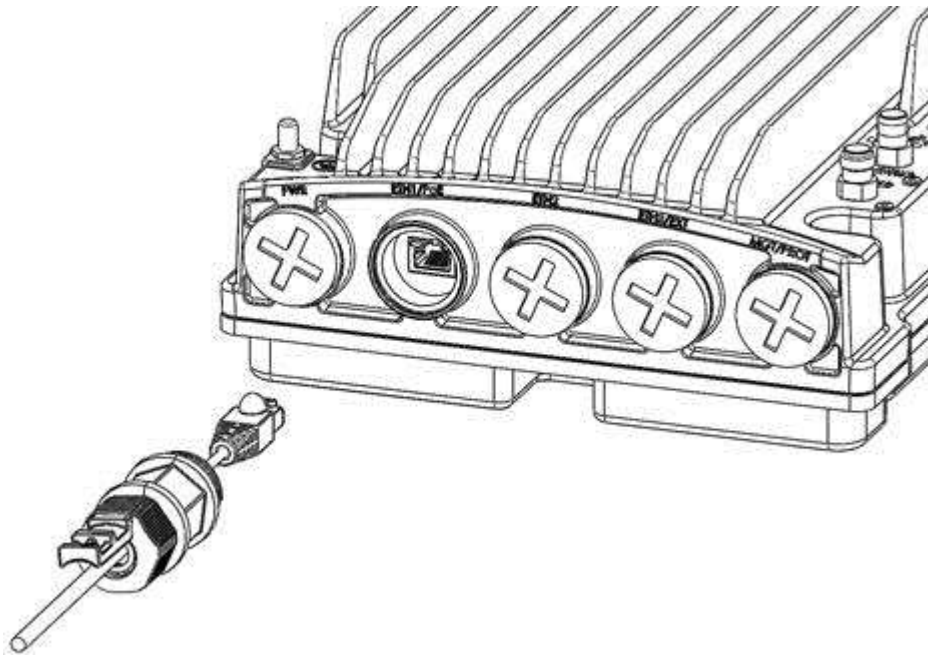

- 3 Screw the gland into the radio unit.

Important Note! Before tightening the gland, make sure the gland is even with the cover. Tighten the gland gently and make sure there is no resistance. If there is resistance, stop immediately and verify that the gland is not being inserted at an angle. Tightening the gland at an angle can ruin the thread on the gland and prevent proper sealing of the interface.

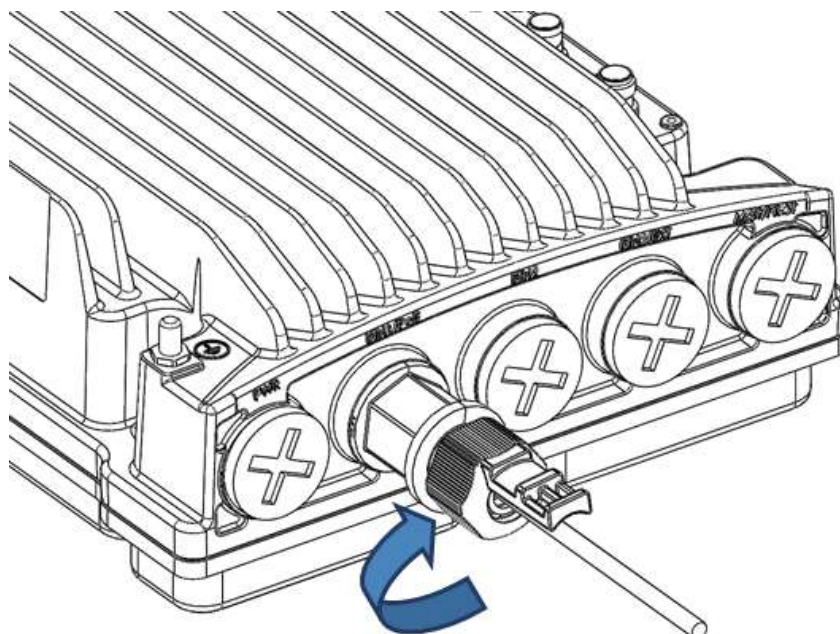

- 4 Tighten the gland cap.
- 5 Secure the cable to the gland using a tie wrap.

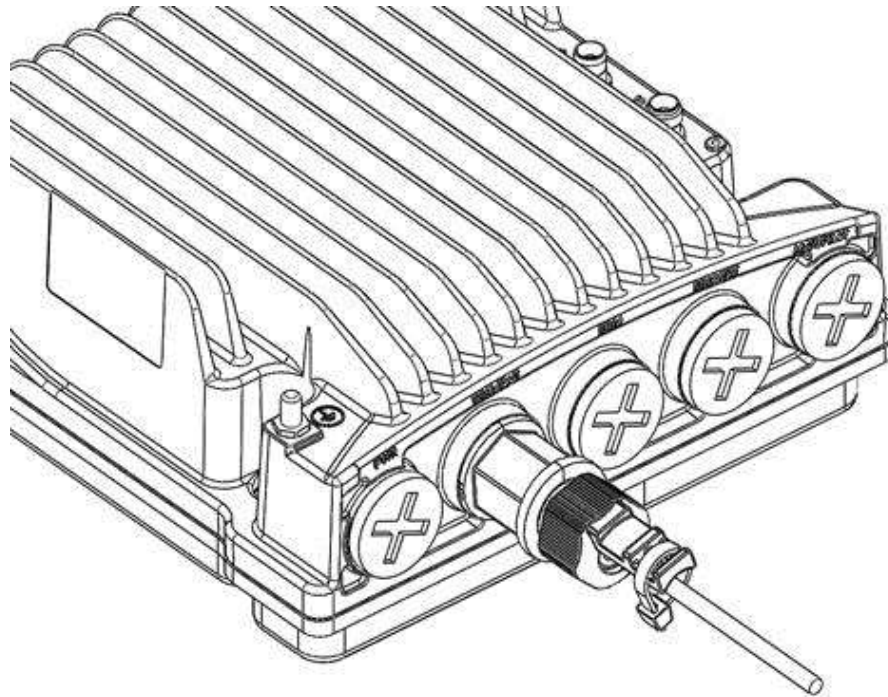

3.11.4 Using a Splitter Cable with P2 of a 2E2SX Hardware Model

In 2E2SX models, P2 is a DisplayPort that uses a special splitter cable and gland (*Table 1*) to accommodate two RJ-45 cables.

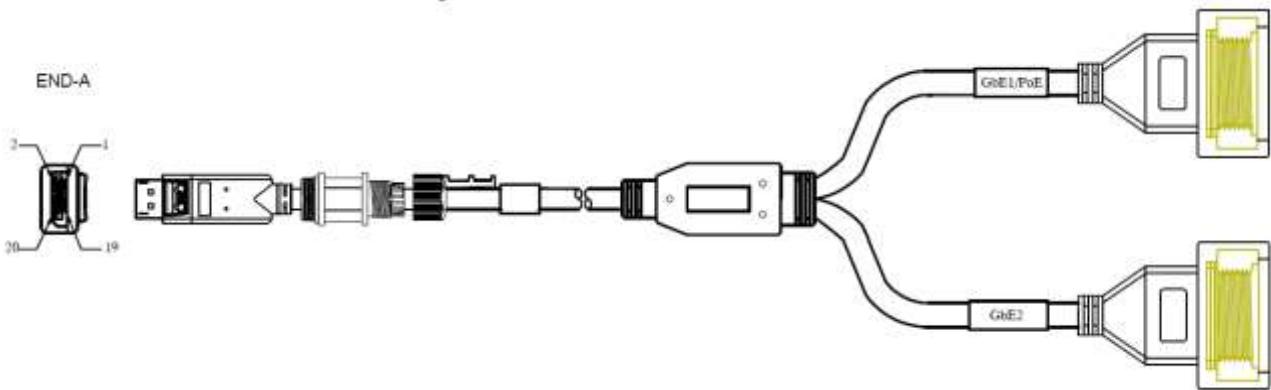

- One end of the cable is labelled GbE1/PoE. This is used for the RJ-45 connection to Eth 1 (traffic/PoE).
- The other end of the cable is labelled GbE2. This is used for the RJ-45 connection to Eth 2 (traffic).

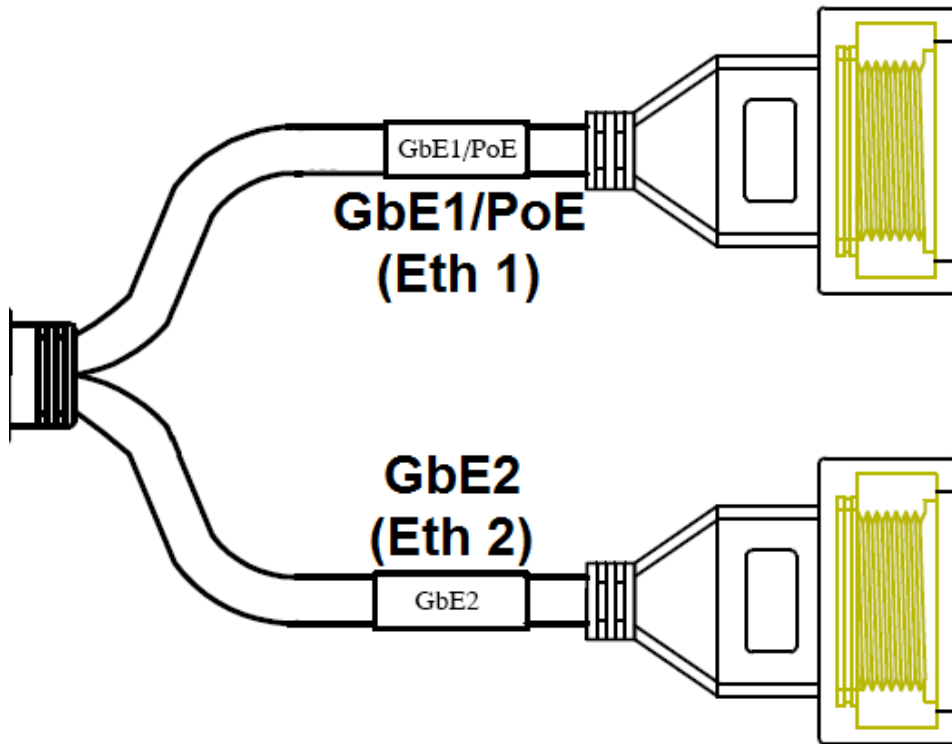

The cable is delivered already inserted in its gland. The gland must be connected to the IP-20C as described in *Connection of Ethernet Cable to IP-20C* on page 58.

Note: The cable's connector includes a locking mechanism. Before attaching the gland, make sure the cable is locked into the DisplayPort.

3.12 Management Connection for 4x4 MIMO and 1+1/2+2 HSB Configurations

In 4x4 MIMO and all HSB protection configurations, two Y-splitter cables and a special signaling cable must be used to connect the management ports (MGT/PROT) of the two IP-20C units and provide management access to each unit.

The MIMO/Protection signaling cables are available pre-assembled from Ceragon in various lengths, but users can also prepare them in the field.

The following sections explain how to prepare and connect these cables.

3.12.1 Preparing a MIMO/Protection Signaling Cable

The MIMO/Protection signaling cables require the following pinouts.

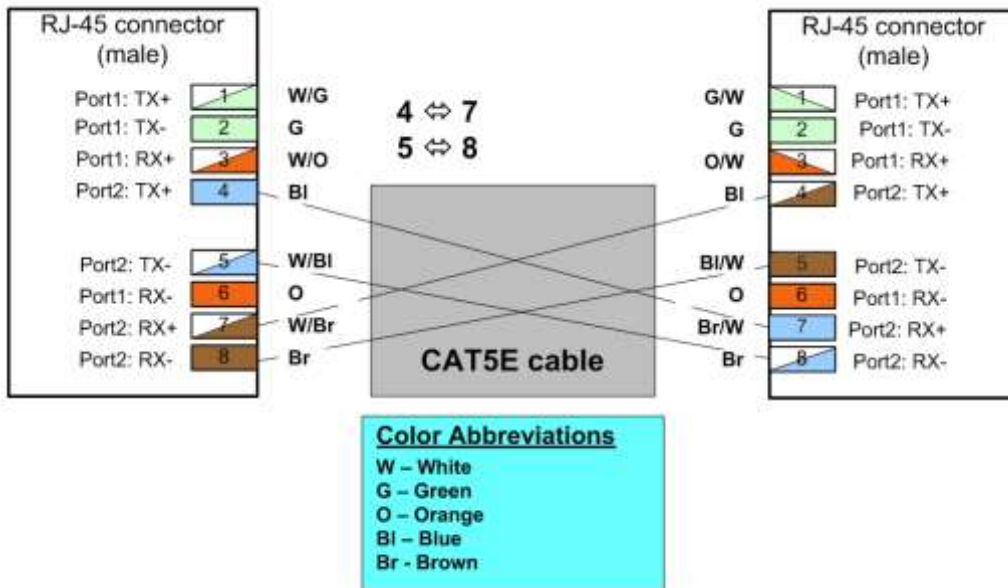

Figure 26: MIMO/Protection Signaling Cable Pinouts

Note: Other than the pinout connection described above, the cable should be prepared according to the cable preparation procedure described in *Connecting the Ethernet Cable* on page 54.

3.12.2 Connecting the MIMO/Protection Splitters and Protection Signaling Cable

Each splitter has three ports:

- System plug (“Sys”) – The system plug should be connected to the IP-20C’s management port.
- Management port (“Mng”) – A standard CAT5E cable should be connected to the splitter’s management port in order to utilize out-of-band (external) management.

Note: Even for systems that use in-band management, initial configuration of a 4x4 MIMO and any HSB protection configuration must be performed manually using out-of-band management.

- MIMO/Protection signaling port (“MIMO/Prot”) – A MIMO/Protection signaling cross cable, as described above, should be connected between this port and the other “MIMO/Prot” port of the second splitter on the mate IP-20C unit.

The following figure demonstrates a 4x4 MIMO configuration in which both IP-20C units are connected to an external management station and to each other, using two splitters.

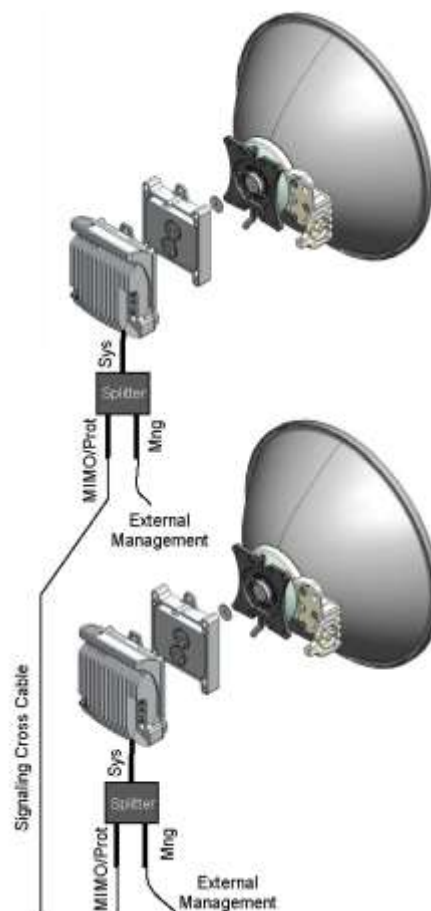

Figure 27: 4x4 MIMO or HSB Protection Configuration with External Management

4. PoE Injector Installation and Connection

4.1 PoE Injector Cable Connection

The PoE Injector cables are connected similar to the IP-20C.

- To connect the Ethernet (CAT5E) cable to the PoE or Data port, refer to *Connection of Ethernet Cable to IP-20C* on page 58.
- To connect the DC power cable to the power port or dual feed port, refer to *Connecting a DC Power Cable* on page 52. This cable is not supplied with the PoE Injector.
- The total length of the cable between the IP-20C port and the Switch/Router the device is connected to should not exceed 100m/328ft. This length includes the connection between the IP-20C and the PoE Injector ($X1 + X2 \leq 100\text{m}/328\text{ft}$ in the figure below).

Note: The length of the cable connecting the customer equipment to the PoE injector should not be longer than 10m (according to ANSI/TIA-568 standard).

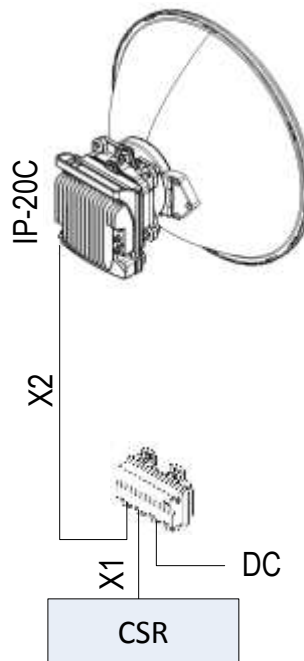

Note! For the warranty to be honored, the connection must be through the glands only. Do not open the PoE injector box cover.

4.2 PoE Injector Grounding

To ground the PoE Injector:

- 1 On the right side of each PoE Injector, loosen the screw, plain washer, and serrated washer.
- 2 Place the cable lug (supplied with the PoE injector kit) between the plain and serrated washer.
- 3 Tighten the screw.
- 4 Perform a resistance test between the 2 lugs of the GND cable. Verify that the result is 0-2 ohms.

4.3 PoE Injector Wall Mount Installation

List of Items

Item	Description	Quantity	Remarks
1	PoE Injector	1	
1	Glands Kit	1	For outdoor installations.

Notes: Glands are required for outdoor installations. The glands kit (three or five glands) is not supplied with the PoE Injector, and must be ordered separately.

Glands Kit

Marketing Model	Marketing Description
IP-20_3xGlands_kit	IP-20_3xGlands_kit
IP-20_Glands_kit	IP-20_Glands_x5_kit

Required Tools

- Metric offset wrench key wrench set
- Hammer
- Drilling Machine

Procedure

- 1 Mount and tighten the PoE Injector to a wall using two M6 bolts and anchors. The M6 bolts and anchors must be purchased separately.

Note: Use Anchor Stainless Steel with flanged Hexagonal nut M6X70.

- 2 Drill two 6mm diameter holes with 100mm distance between the centers of the holes.
- 3 Insert the anchors with the bolts.
- 4 Place the washers on the bolt.

5 Tighten the nuts.

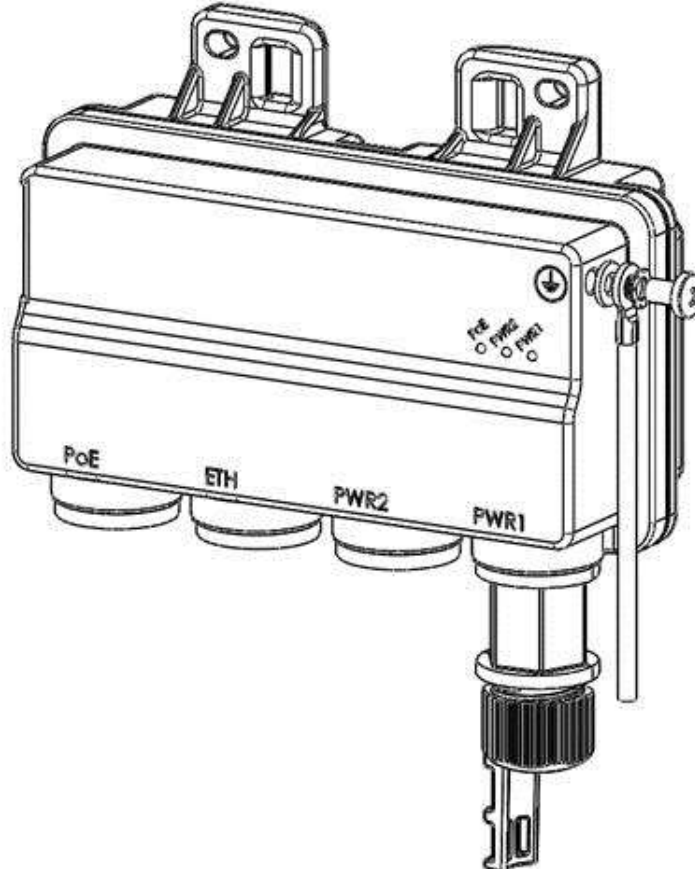
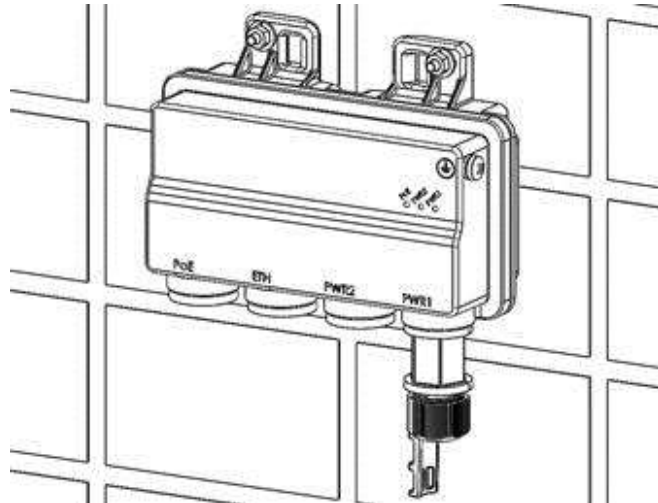
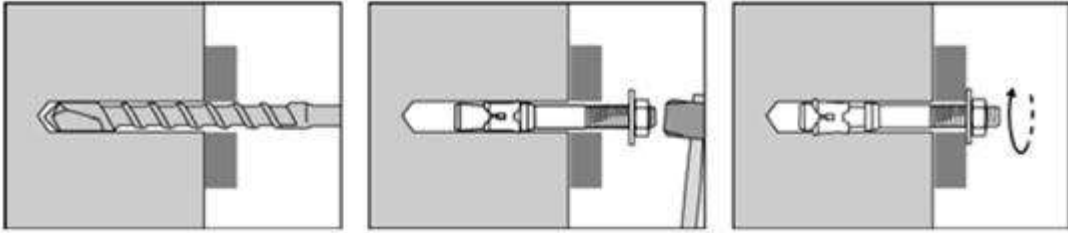

4.4 PoE Injector Pole Mount Installation

List of Items

Item	Description	Quantity	Remarks
1	PoE Injector	1	

Required Tools

- Slot Screwdriver

Procedure

To mount the PoE Injector on a pole:

- 1 Mount and tighten the PoE Injector to a pole with a diameter of 114 mm using a stainless steel hose clamp.
- 2 Pass the hose clamp through the pole mount slots.

Note! The Hose Clamp is not supplied with PoE injector kit.

- 3 Attach the PoE injector to the pole.
- 4 Connect the ends of the hose clamp.
- 5 Tighten the hose clamp using the captive screw.

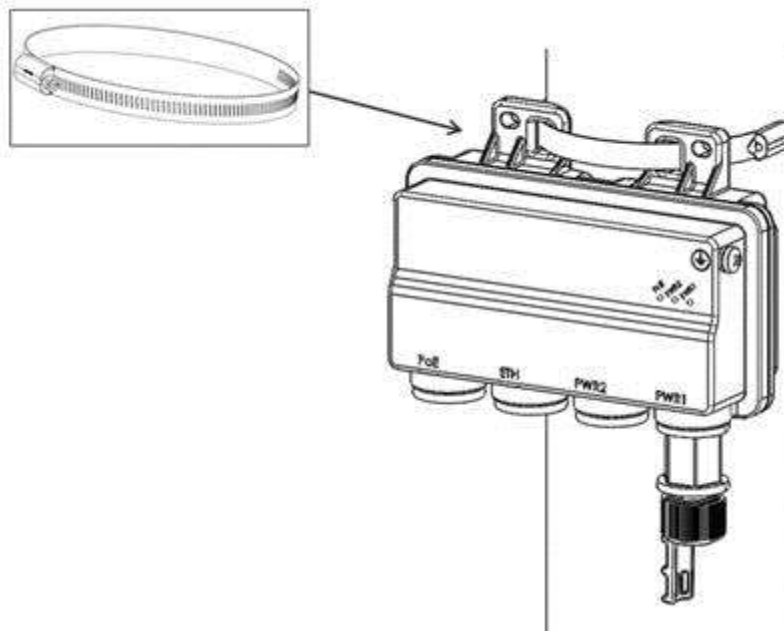

4.5 PoE Injector 19" Rack Installation

List of Items

Item	Description	Quantity	Remarks
1	PoE Injector	1	
2	PoE Injector 19" Rack Mount Kit	1	

Required Tools

- Philips Screwdriver

To mount the PoE Injector on a rack:

- 1 Mount the PoE Injector to a 19" rack using a 19" rack adaptor.
- 2 Mount the PoE Injector on the 19" adaptor through the wall mounting holes, using M6 screws and washers.

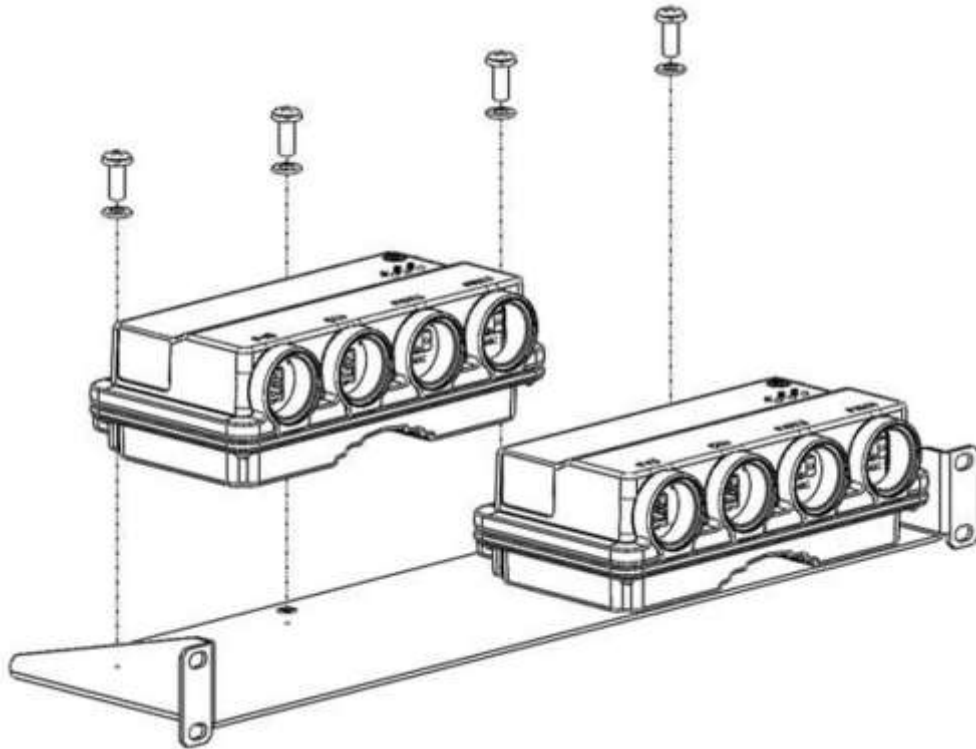

- 3 Mount the 19" rack adaptor to a 19" rack using four M6 screws and cage nuts.

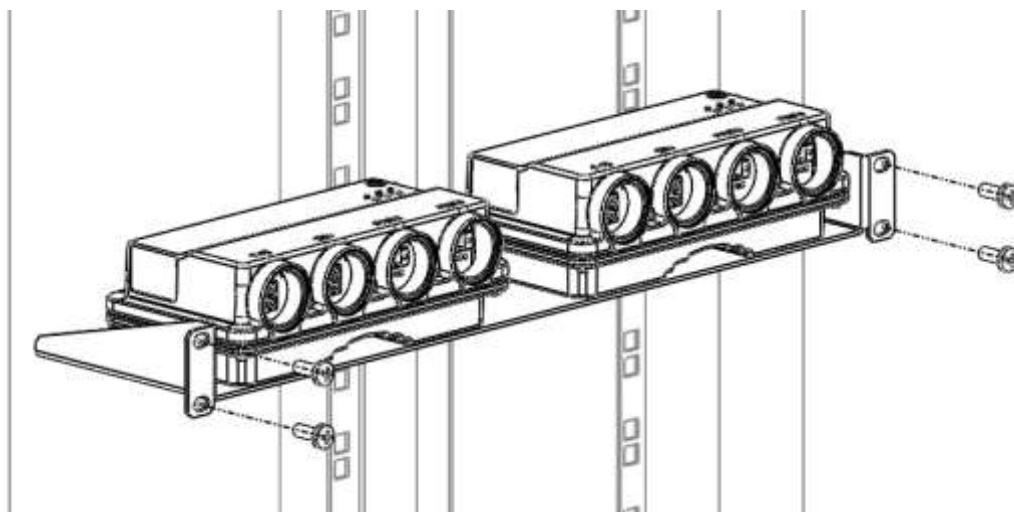

4.6 PoE Injector ETSI Rack Installation

List of Items

Item	Description	Quantity	Remarks
1	PoE Injector	1	
2	PoE Injector ETSI Rack Mount Kit	1	

Required Tools

- Philips Screwdriver

To mount the PoE Injector to an ETSI rack:

- 1 Mount the PoE Injector to an ETSI rack using a 19" rack adaptor and ETSI adapting ears.
- 2 Connect the ETSI adapting ears to a 19" rack adaptor using four M6 screws.

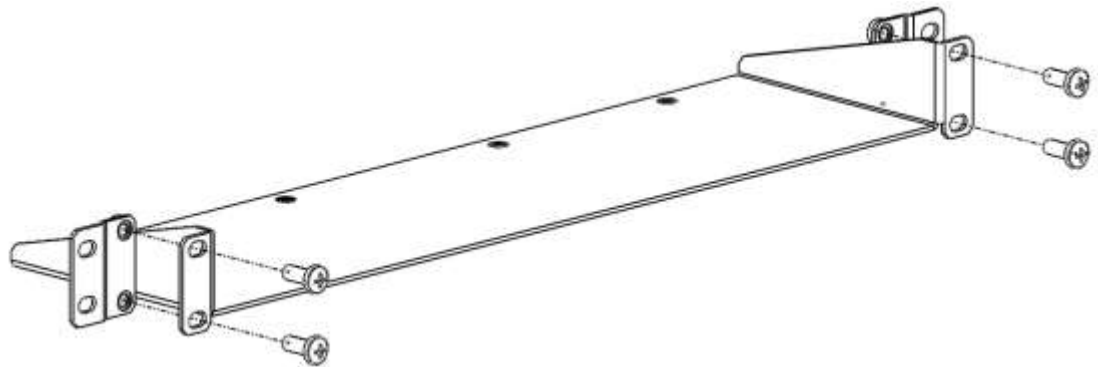

- 3 Mount the PoE Injector on the adaptor through the wall mounting holes using M6 screws and washers.

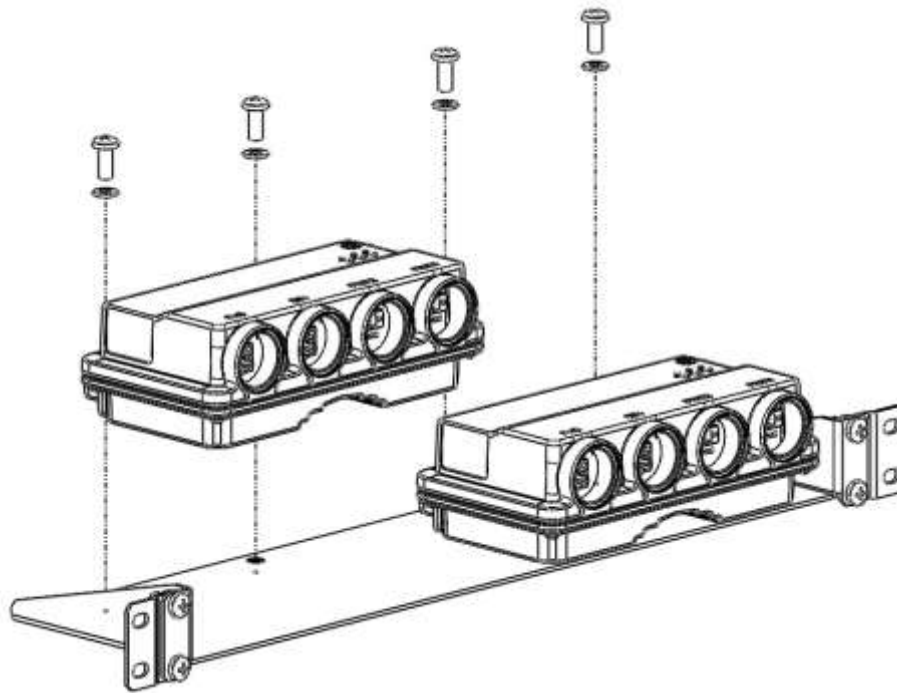

- 4 Mount the 19" rack adaptor with the ETSI ears on the ETSI rack using four M6 screws and cage nuts.

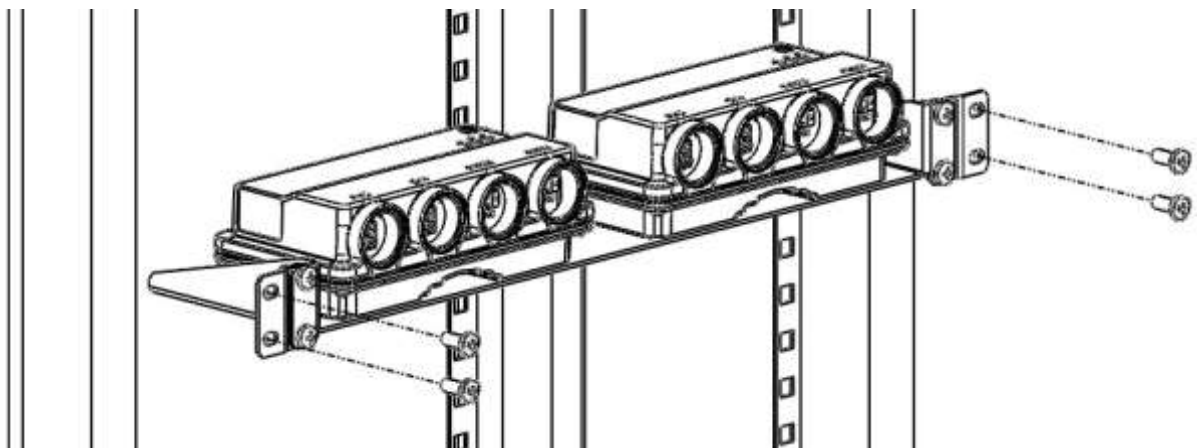

Note: For this type of installation, a 2RU space is required.

5. Generic Installation Procedures

5.1 General Notes Concerning All Installation Procedures

Since the IP-20C architecture is of a Dual Core nature, each dual core configuration can be considered as single core configuration hardware ready for its dual core counterpart. Therefore, you should follow the same procedure for $2+0$ SP installation, if you want to install a $1+0$ SP HW ready for $2+0$ SP.

One of the major benefits of the IP-20C and the dual core architecture is that upgrading can be done remotely by uploading the correct software license.

Before starting an installation, use a leveler to make sure that the poles are 100% vertical. You need to check both sides of each pole at 90 degrees separation. This is a critical step in any link but most important when installing MIMO or XPIC.

Important! Do not remove the transparent pressure windows located on the antenna interfaces.

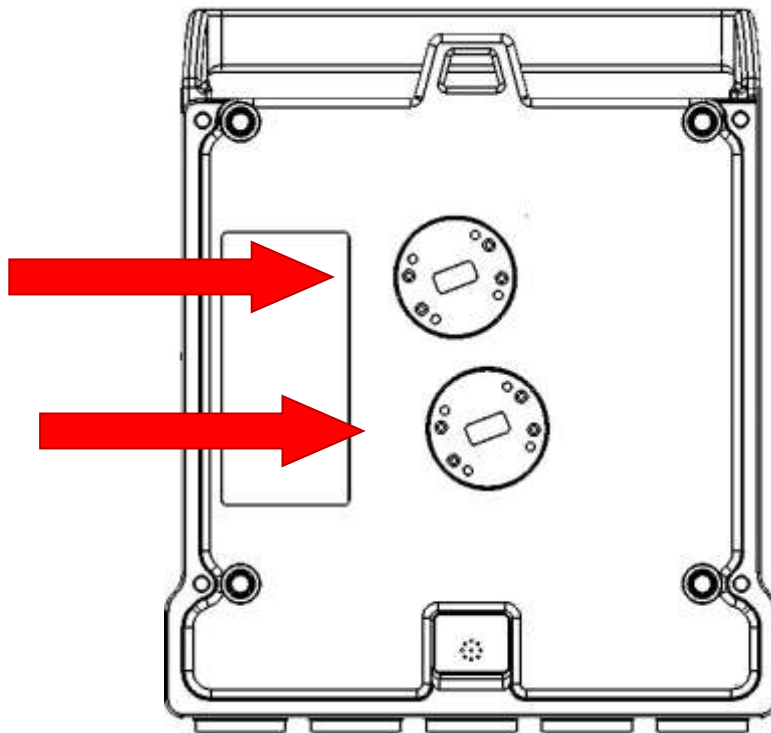

Figure 28: Transparent Pressure Windows

5.2 Torque Requirements

When tightening the captive screws, use 20 Nm torque for radio-antenna, radio-mediation device, and mediation device-antenna connections. In order to avoid misalignment, screws should be tightened progressively.

When fastening a waveguide to the radio or mediation device, use the following torque, according to frequency and screw type:

- 6 GHz: M5/#10-32: 3.5 Nm
- 7/8-15 GHz: M4/#8-32: 2.5 Nm
- 18-42 GHz: M3/#4-40: 1Nm

5.3 IP-20C DC Pole Mount Procedure

Note! The pole diameter range for pole mount installations is 8.89 cm – 11.43 cm (3.5 inches – 4.5 inches).

List of Items

Item	Description	Quantity	Remarks
1	IP-20C DC POLE MOUNT KIT	1	
2	IP-20C DC REMOTE MOUNT ADAPTOR KIT	1	From 6-13GHz

Required Tools

- Metric offset wrench key wrench set

To install the IP-20C pole mount:

Mount and tighten the IP-20C DC pole mount to a pole with a diameter of 114 mm using the four washers and screws supplied with the IP-20C DC pole mount kit.

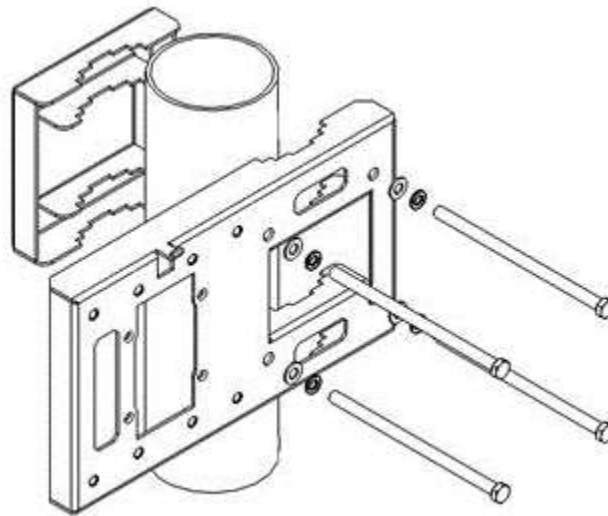

For 6-13 GHz Only

Mount and tighten the IP-20C Remote Mount Adaptor plate (supplied in IP-20C Adaptor Remote Mount kit) to the IP-20C Pole Mount using the four flat screws supplied with the IP-20C Adaptor Remote Mount kit.

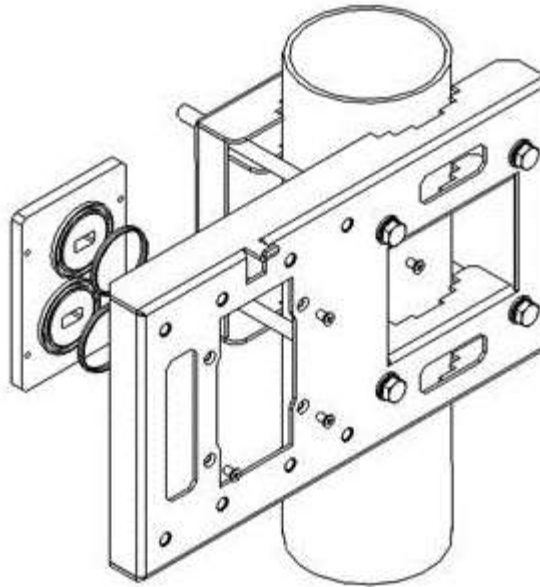

5.4 Remote Mount Installation for Single Polarization with an Imperial Waveguide

List of Items

Item	Description	Quantity	Remarks
1	IP-20C RADIO	1	
2	RFU-C ADAPTATION KIT TO FLEXIBLE WG IMPERIAL	1	From 6-13 GHz
3	RFU-C REMOTE POLE MOUNT KIT	1	
4	IP-20C SPLITTER KIT	1	

Required Tools

- Metric offset hexagon key wrench set
- Imperial offset hexagon key wrench set
- Phillips #1, #2 screwdriver

5.4.1 6-13GHz Installation Procedure

- 1 Mount and tighten the RFU-C Adaptor plate (supplied in RFU-C Adaptation kit to Flexible WG Imperial) to the RFU-C Remote Pole Mount using the four flat screws supplied with the RFU-C Adaptation kit to Flexible WG Imperial.

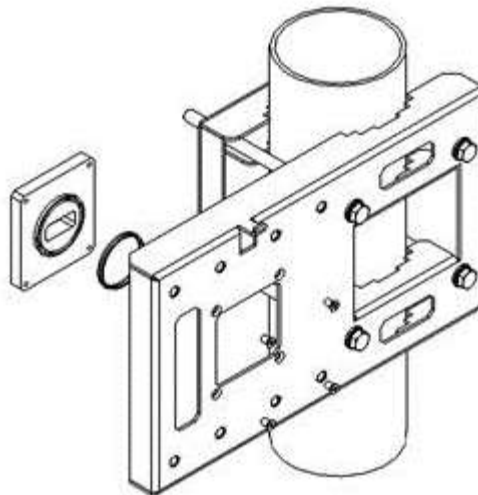

- 2 Mount and tighten the IP-20C Splitter to the RFU-C Remote Pole Mount using the four captive screws and washers that are assembled to the IP-20C Splitter kit.

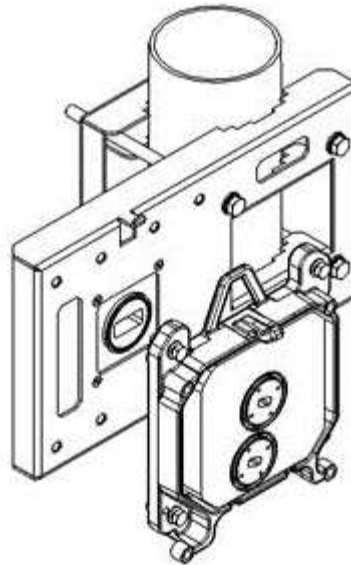

- 3 Mount and tighten the IP-20C radio to the IP-20C Splitter using the four captive screws and washers that are assembled to the IP-20C radio. Pay attention that the O-rings are mounted on the IP-20C Splitter kit.

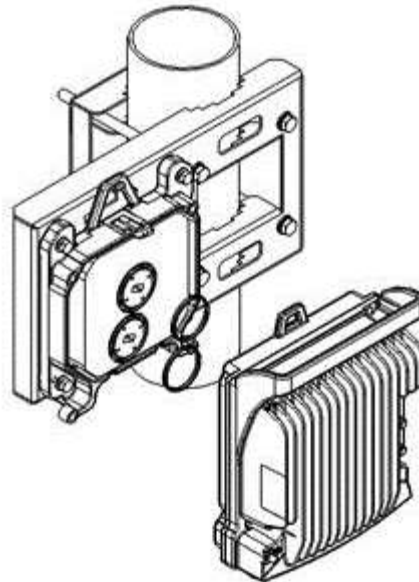

- 4 Connect the Flexible Waveguide and Sealing Gasket supplied with the Flexible Waveguide Imperial Kit to the RFU-C Adaptor plate. Tighten the four screws supplied with the Flexible Waveguide Imperial Kit.

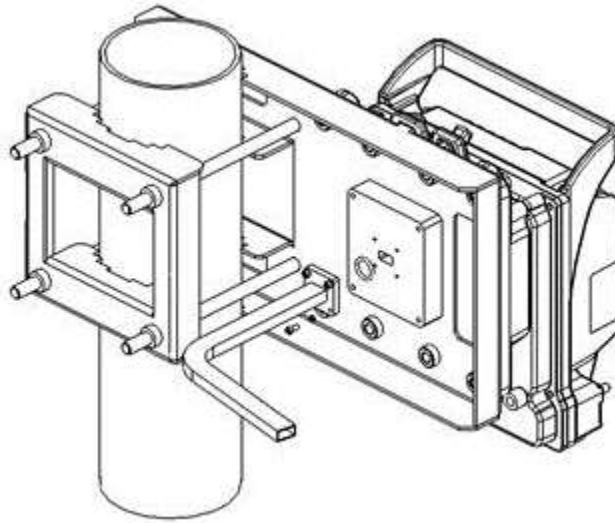

5.4.2 15-42GHz Installation Procedure

- 1 Loosen the two screws, and remove the twist plate from the IP-20C Splitter.

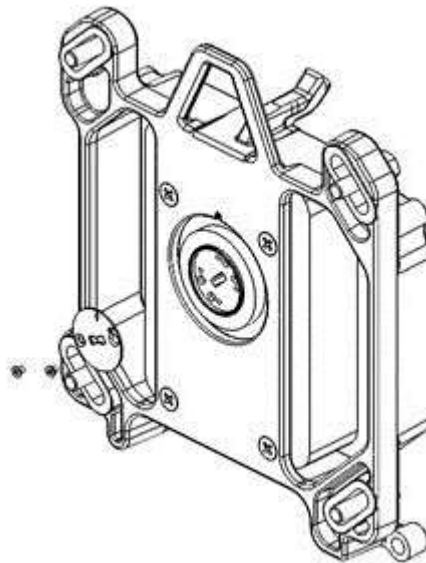

- 2 Mount and tighten the IP-20C Splitter to the RFU-C Remote Pole Mount using the four captive screws and washers that are assembled to the IP-20C Splitter kit.

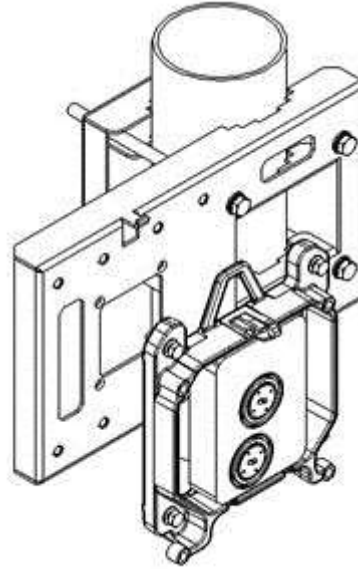

- 3 Mount and tighten the IP-20C radio to the IP-20C Splitter using the four captive screws and washers that are assembled to the IP-20C radio. Make sure the O-rings are mounted on the IP-20C Splitter kit.

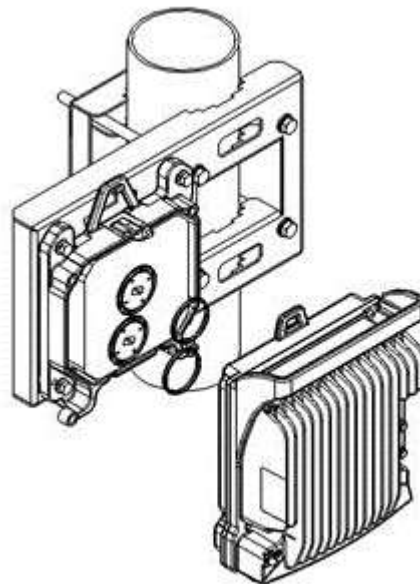

- 4 Connect the Flexible Waveguide and Sealing O-ring supplied with the Flexible Waveguide Imperial Kit to the IP20-C Splitter kit. Tighten the four screws supplied with the RFU-C Adaptation kit to the Flexible Waveguide Imperial.

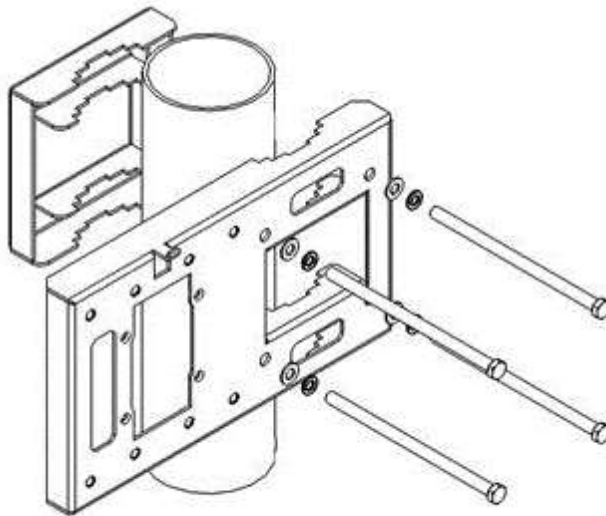
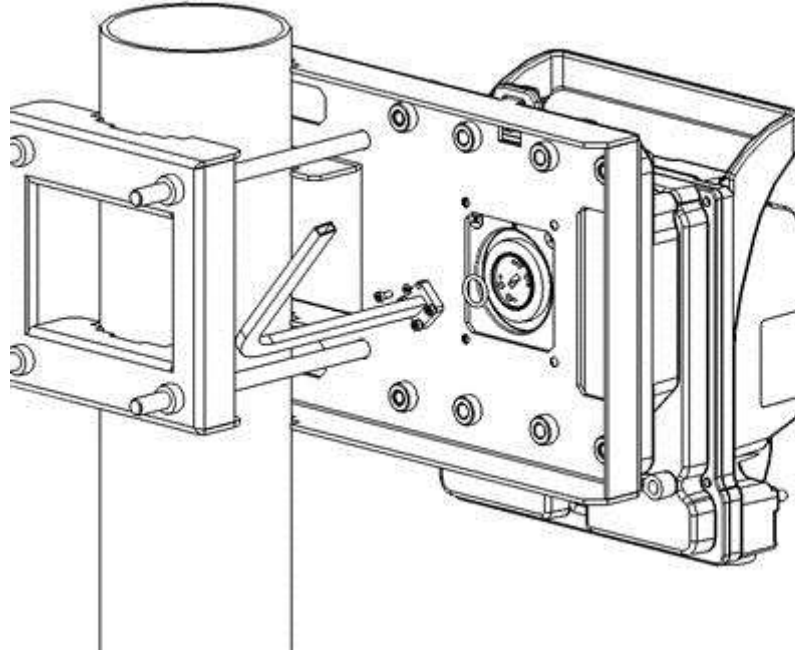

6. Installation Procedures per Configuration Type

6.1 MultiCore 2+0 Dual Polarization Direct Mount

Note! This procedure can also be used for MultiCore 1+0 DP HW ready for MultiCore 2+0 DP configuration.

CCDP

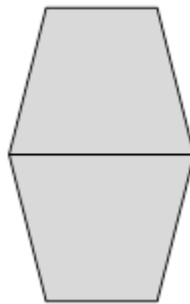

List of Items

Item	Description	Quantity	Remarks
1	IP-20C RADIO	1	
2	IP-20C OMT kit	1	
3	CIRC./CIRC. ADAPTOR	1	Per Antenna Vendor

Required Tools

- Metric offset hexagon key set
- Metric wrench key set

Procedure

- 1 Prior to the installation, follow the antenna manufacturer’s instructions to use the circular adaptor. (Remove the existing rectangular transition, swap the O-ring, and install the circular transition instead.)



- 2 Connect the OMT Kit to the antenna and secure it with four screws. Verify the existence of the O-ring.

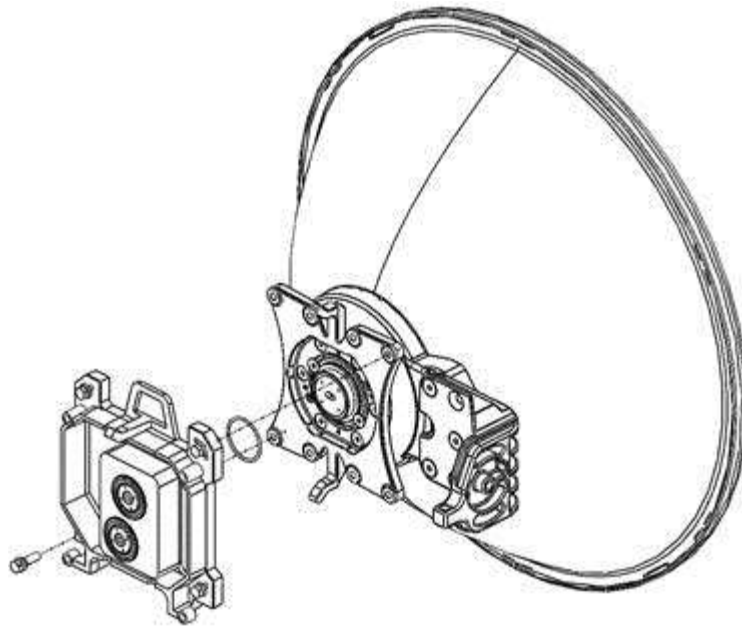

- 3 Connect the IP-20C DC radio to the OMT Kit using the four M8 captive screws and washers supplied, and tighten the screws.

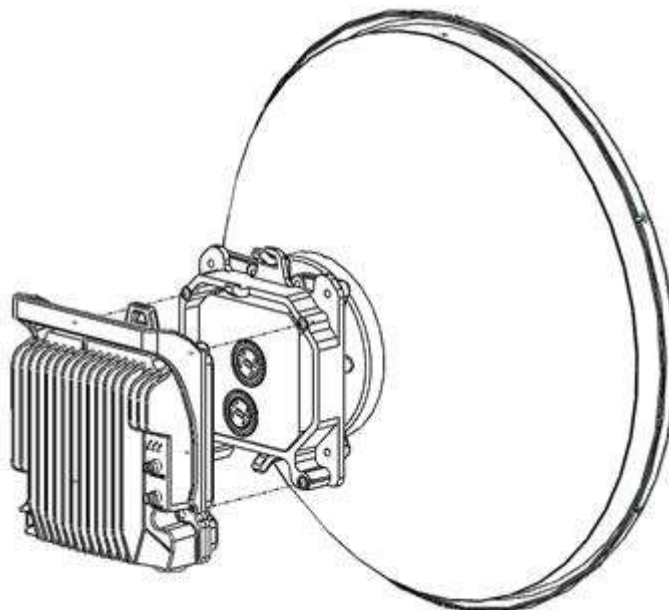

6.2 MultiCore 2+0 Dual Polarization Remote Mount

This procedure is for use with Interface antennas, up to six feet.

For standard interface antennas (six feet and larger), no OMT and no Circ./Circ. Adaptor are used, and the flexible waveguides are connected directly to the antenna flanges. For instructions how to connect the waveguides to the antenna flanges, refer to the antenna vendor's documentation.

Note! This procedure can also be used for MultiCore 1+0 DP HW ready for MultiCore 2+0 DP configurations.

CCDP

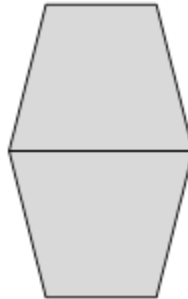

List of Items

Item	Description	Quantity	Remarks
1	IP-20C RADIO	1	
2	IP-20C OMT kit	1	Not used for standard interface antennas (six feet and larger).
3	FLEXIBLE WG KIT	2	
4	IP-20C DC POLE MOUNT KIT	1	
5	IP-20C DC REMOTE MOUNT ADAPTOR KIT	1	From 6-13GHz
6	Circ./Circ. Adaptor	1	Per Antenna Vendor. Not used for standard interface antennas (six feet and larger).

Required Tools

- Metric offset hexagon key set
- Metric wrench key set
- Phillips #1, #2 screwdriver

6.2.1 Common Installation

- 1 Prior to the installation, follow the antenna manufacturer's instructions to use the circular adaptor. (Remove the existing rectangular transition, swap the O-ring, and install the circular transition instead.)



- 2 Connect the OMT Kit to the antenna and secure it with four screws. Verify the existence of the O-ring.

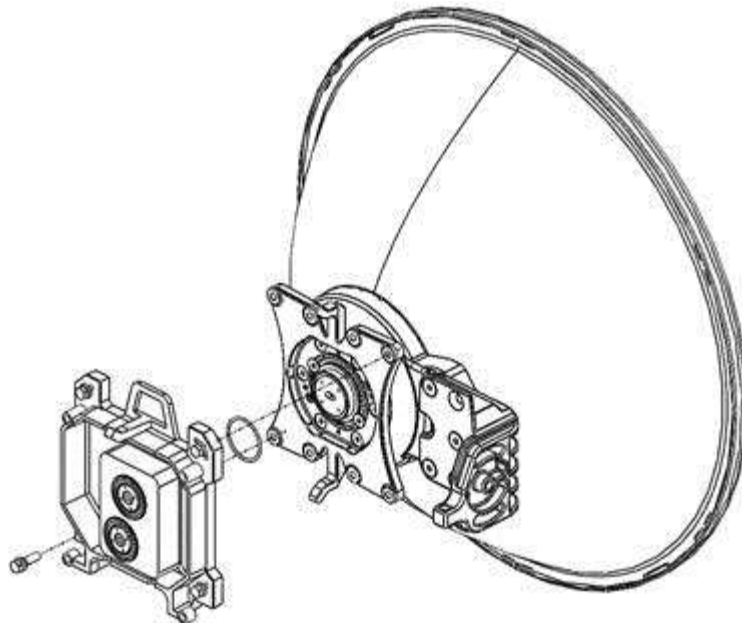

- 3 Mount and tighten the O-ring and the Flexible WG to IP-20C OMT ports using the four screws supplied with the Flexible WG kit.

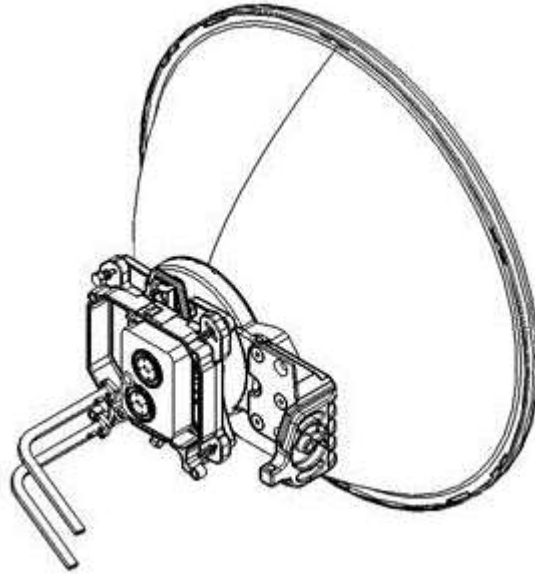

6.2.2 6-13 GHz

- 1 Mount and tighten the IP-20C Remote Mount Adaptor plate (supplied in IP-20C Adaptor Remote Mount kit) to the IP-20C Pole Mount using the four flat screws supplied with the IP-20C Adaptor Remote Mount kit.

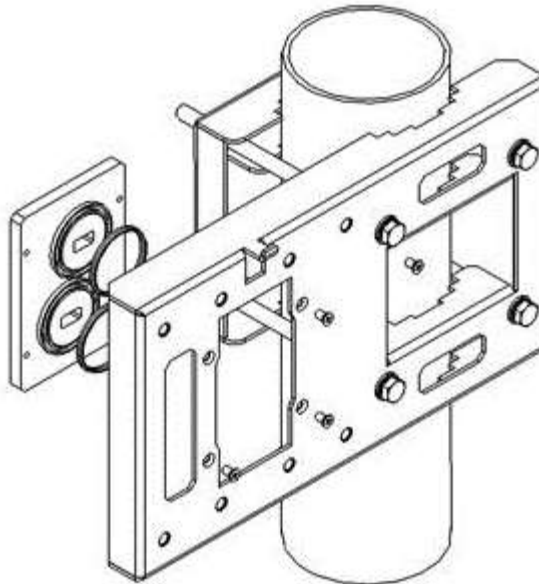

- 2 Mount and tighten the IP-20C to the IP-20C Pole Mount using the four captive screws and washers that are supplied with the IP-20C. Pay attention that the O-rings are mounted on the IP-20C Remote Mount Adaptor.

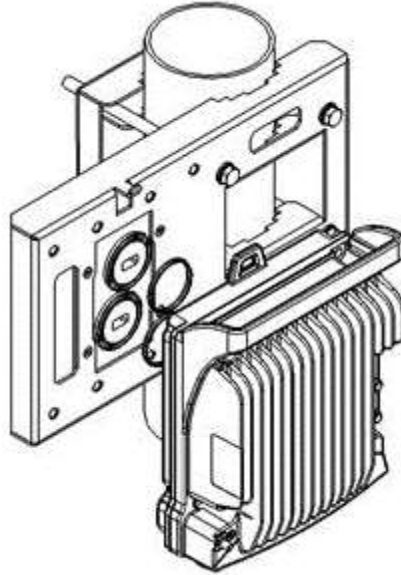

- 3 Mount and tighten both Flexible WGs with their O-ring to the IP-20C Remote Mount Adaptor ports using the four screws supplied with each Flexible WG kit.

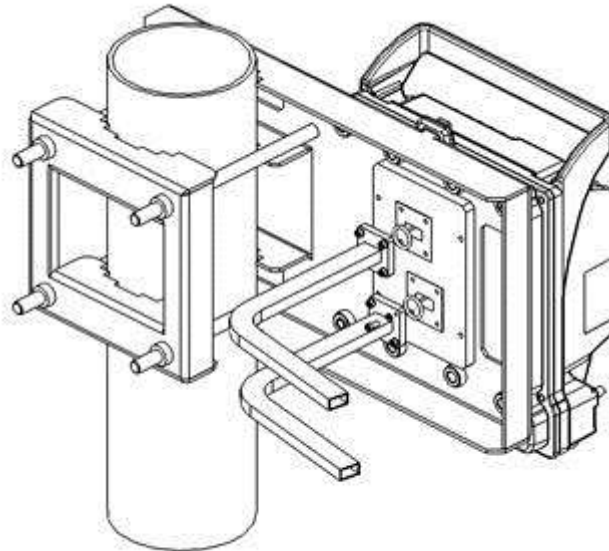

6.2.3 15-42 GHz

- 1 Mount and tighten the IP-20C to the IP-20C DC Pole Mount using the four screws assembled on the IP-20C.

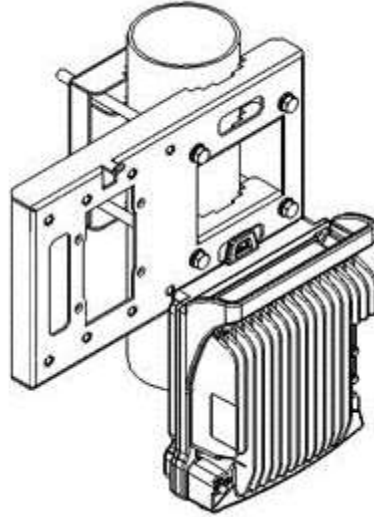

- 2 Mount and tighten the O-ring and the Flexible WG to IP-20C radio ports using the four screws supplied with the Flexible WG kit.

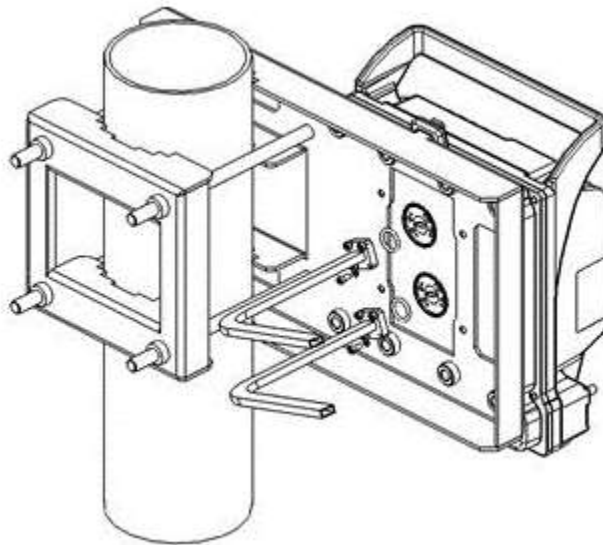

6.3 MultiCore 2+0 Single Polarization Direct Mount

Note! This procedure can also be used for MultiCore 1+0 SP HW ready for MultiCore 2+0 SP configuration.

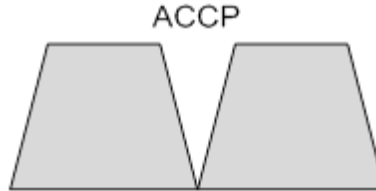

List of Items

Item	Description	Quantity	Remarks
1	IP-20C RADIO	1	
2	IP-20C Splitter KIT	1	

Required Tools

- Metric offset hexagon key set
- Phillips #1, #2 screwdriver

Procedure

- 1 Adjust the twist on the Splitter Kit. Perform one of the following steps, according to the required polarization (horizontal or vertical).
 - For horizontal polarization, locate the holes above and below the letter "H" on the pins and fasten the two screws.

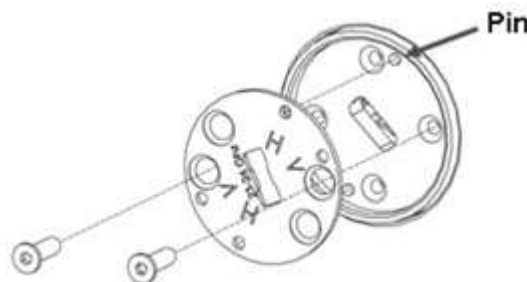

- For vertical polarization, locate the holes above and below the letter “V” on the pins and fasten the two screws.

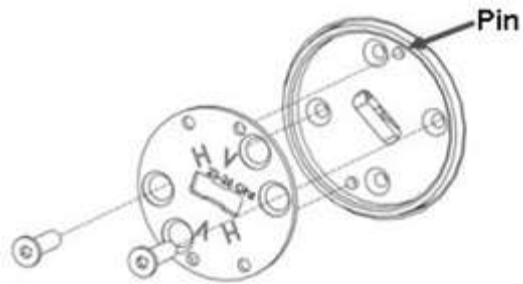

- 2 Mount and tighten the IP-20C Splitter Kit on the antenna using the four M8 screws and washers.
- 3 Mount and tighten the IP-20C to the IP-20C Splitter Kit using the four M8 captive screws and washers supplied.

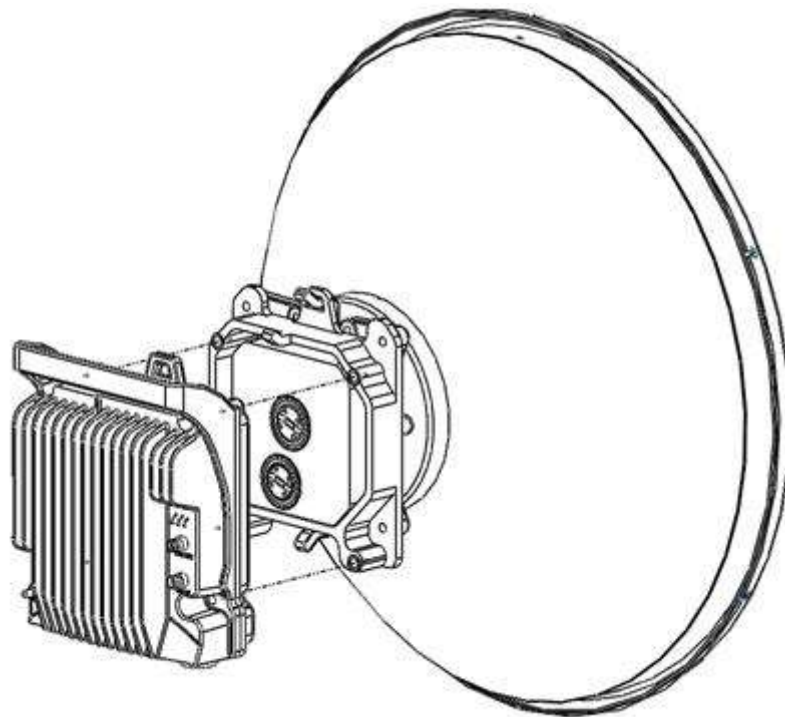

6.4 MultiCore 2+0 Single Polarization Remote Mount

Note! This procedure can also be used for MultiCore 1+0 SP HW ready for MultiCore 2+0 SP configurations.

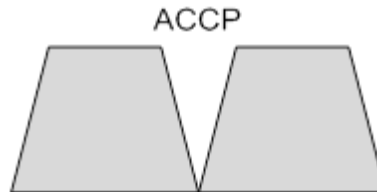

List of Items

Item	Description	Quantity	Remarks
1	IP-20C RADIO	1	
2	RFU-C ADAPTOR REMOTE MOUNT KIT	1	From 6-13 GHz
3	RFU-C POLE MOUNT KIT	1	
4	IP-20C SPLITTER KIT	1	
5	FLEXIBLE WG KIT	1	

Required Tools

- Metric offset hexagon key wrench set
- Phillips #1, #2 screwdriver
- Metric wrench key set

6.4.1 6-13 GHz

- 1 Mount and tighten the RFU-C Remote Mount Adaptor plate (supplied in RFU-C Adaptor Remote Mount kit) to the RFU-C Pole Mount using the four flat screws supplied with the RFU-C Adaptor Remote Mount kit.

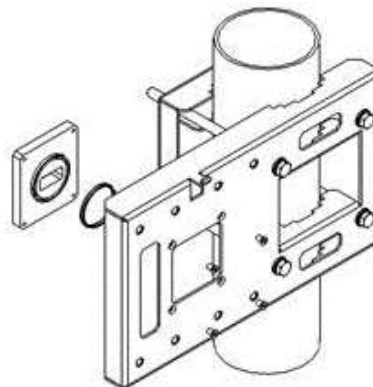

- 2 Mount and tighten the IP-20C Splitter to the RFU-C Pole Mount using the four captive screws and washers that are assembled to the IP-20C Splitter kit.

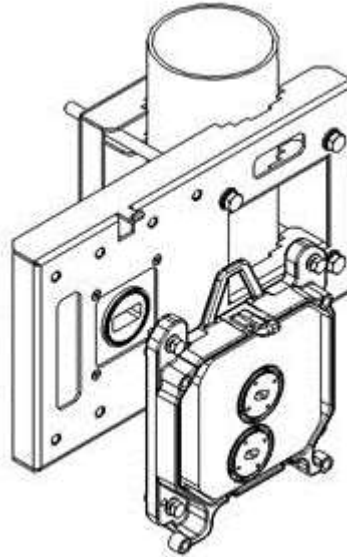

- 3 Mount and tighten the IP-20C to the IP-20C Splitter using the four captive screws and washers that are assembled to the IP-20C radio. Pay attention that the O-rings are mounted on the IP-20C Splitter kit.

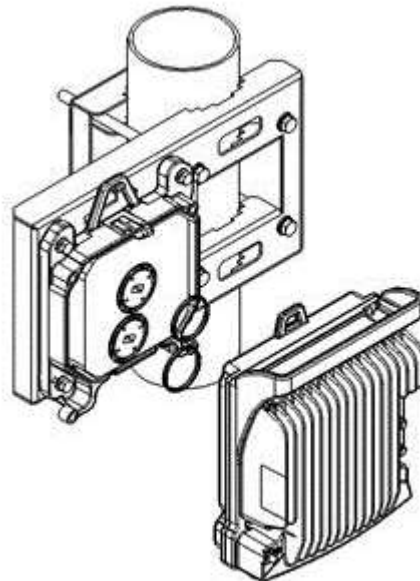

- 4 Connect the Flexible Waveguide and Sealing Gasket supplied with the Flexible Waveguide Kit to the RFU-C Adaptor plate. Tighten the four screws supplied with the Flexible Waveguide Kit.

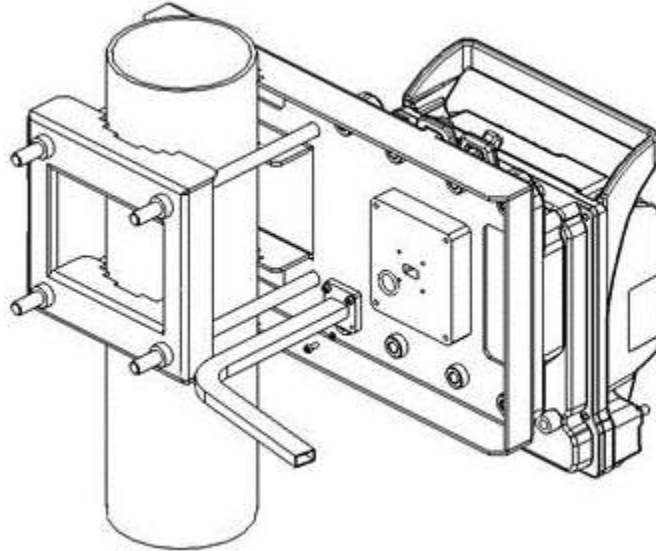

6.4.2 15-42 GHz

- 1 Loosen the two screws and remove the twist plate from the IP-20C Splitter.

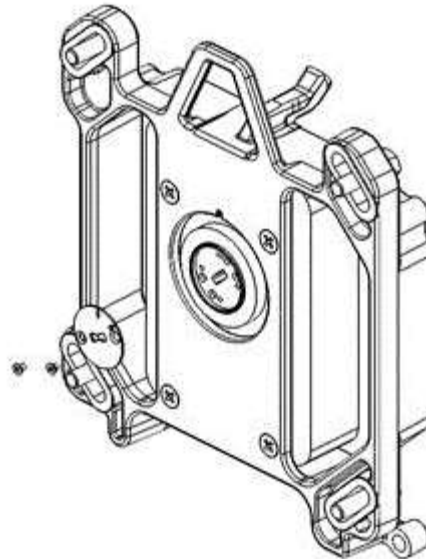

- 2 Mount and tighten the IP-20C Splitter to the RFU-C Pole Mount using the four captive screws and washers that are assembled to the IP-20C Splitter kit.

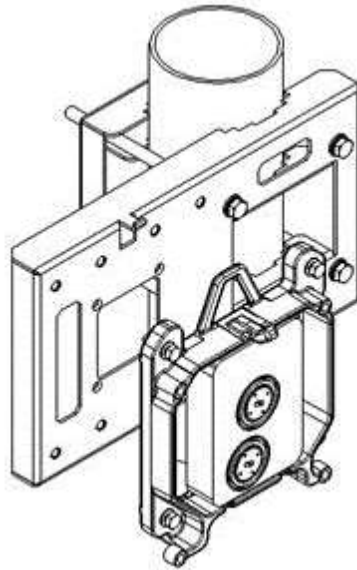

- 3 Mount and tighten the IP-20C to the IP-20C Splitter using the four captive screws and washers that are assembled to the IP-20C. Pay attention that the O-rings are mounted on the IP-20C Splitter kit.

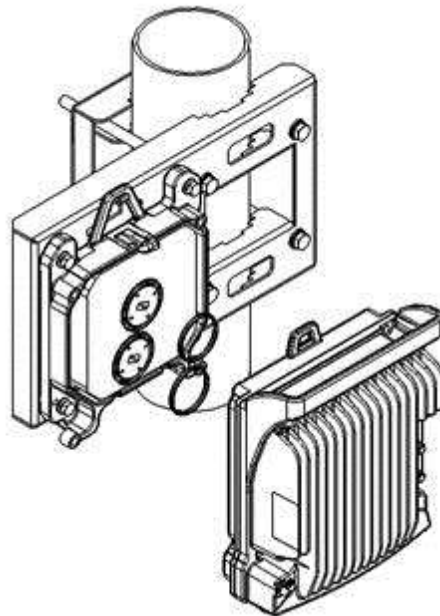

- 4 Connect the Flexible Waveguide and Sealing Gasket supplied with the Flexible Waveguide Kit to the IP20-C Splitter kit. Tighten the four screws supplied with the Flexible Waveguide kit.

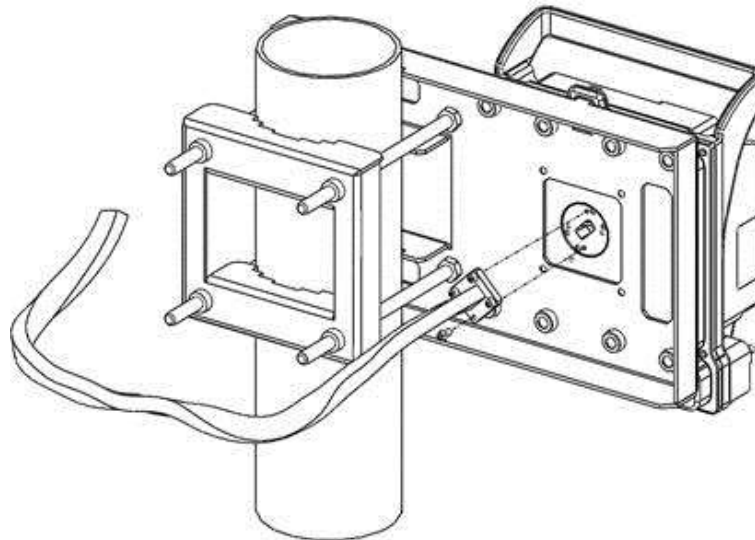

6.5 MultiCore 2+2 HSB Double Polarization Direct Mount

Note! This procedure can also be used for 2 x MultiCore 1+1 HSB DP HW ready for MultiCore 2+2 HSB DP configurations.

CCDP - Protected

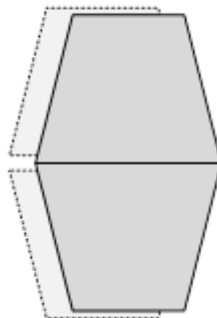

List of Items

Item	Description	Quantity	Remarks
1	IP-20C RADIO	2	
2	IP-20C OMT KIT	1	
3	IP-20C DUAL COUPLER KIT	1	
4	CIRC./CIRC. ADAPTOR	1	Per Antenna Vendor

Required Tools

- Metric offset hexagon key set
- Metric wrench key set

Procedure

- 1 Prior to the installation, follow the antenna manufacturer's instructions to use the circular adaptor. (Remove the existing rectangular transition, swap the O-ring, and install the circular transition instead.)



- 2 Connect the IP-20C OMT Kit to the antenna and secure it with four screws. Verify existence of the O-ring.

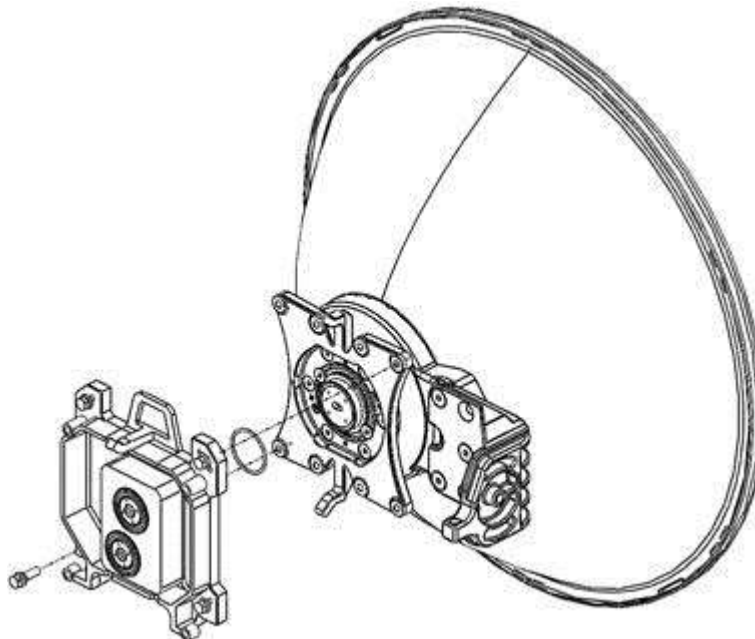

- 3 Connect the IP-20C Dual Coupler Kit to the OMT Kit using four M8 screws and washers, and tighten the screws.

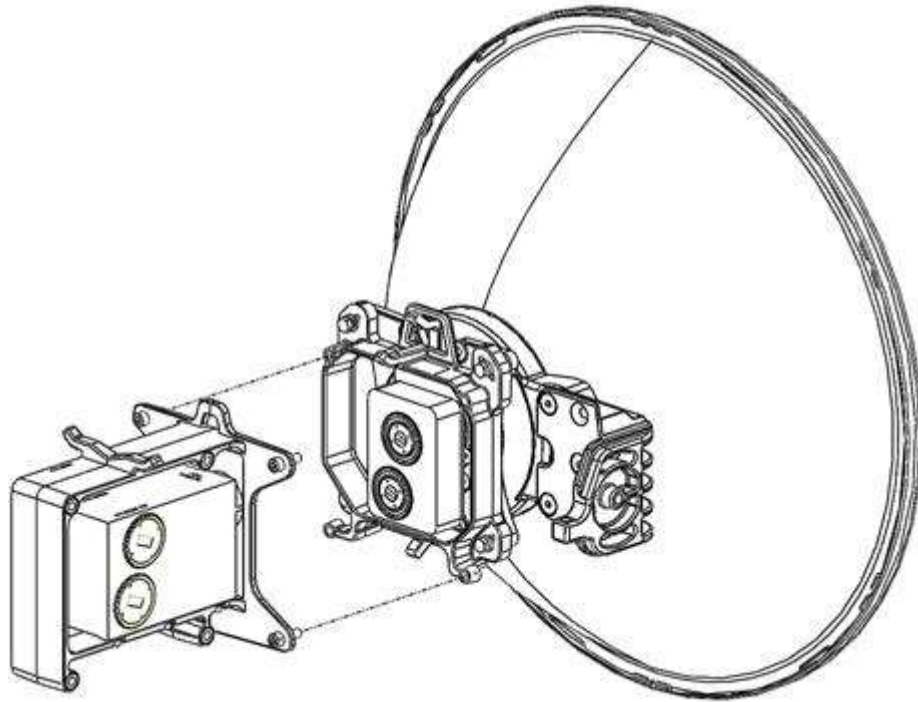

- 4 Mount and tighten the IP-20C DC radio unit to both sides of the Dual Coupler Kit using the supplied captive screws and washers. Pay attention that the O-rings are correctly mounted on the radio ports of the IP-20C Dual Coupler.

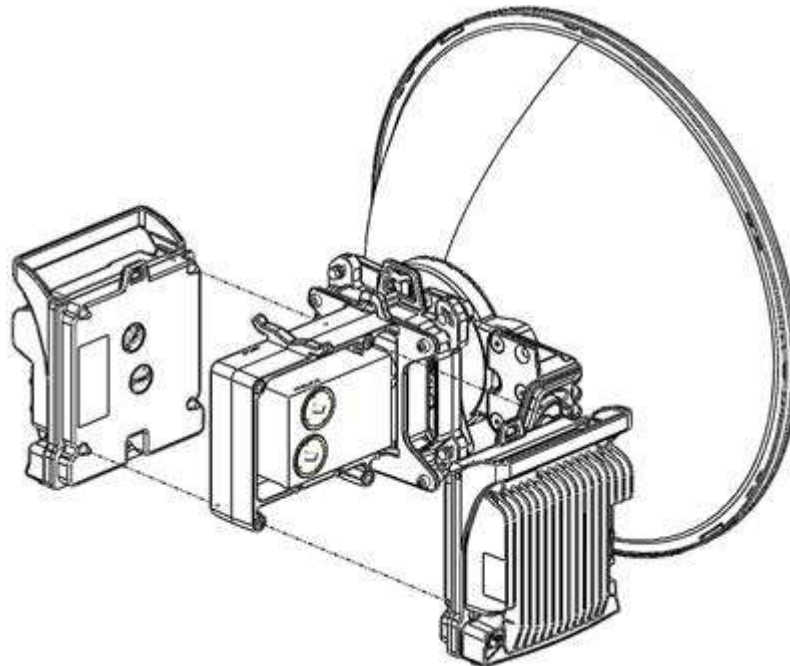

- 5 Connect the MIMO signaling cable between the management ports of both units. For additional instructions on preparing and connecting this cable, refer to *Preparing a MIMO/Protection Signaling Cable* on page 62.

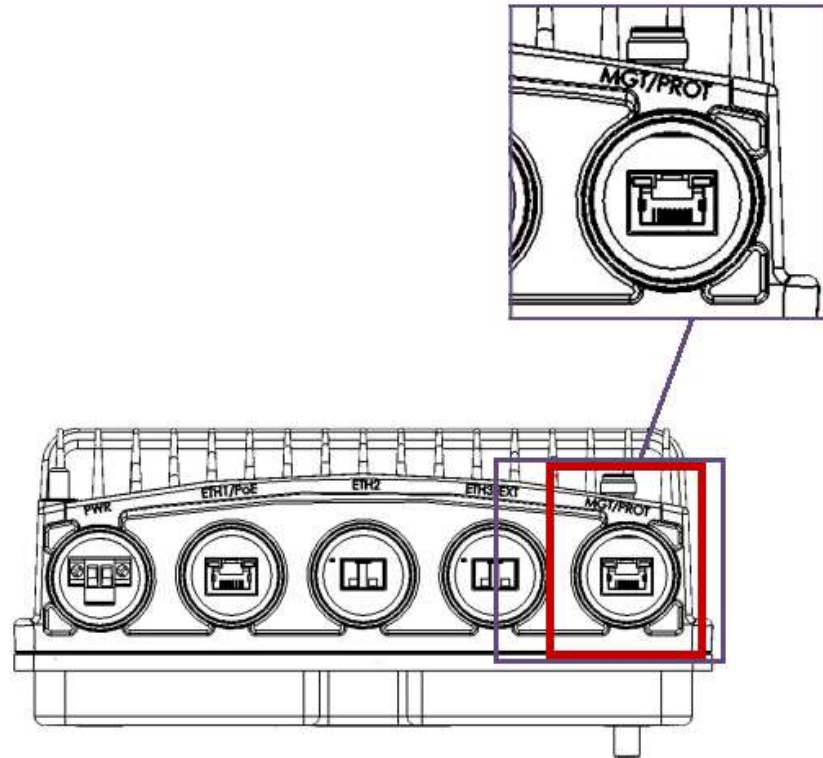

6.6 MultiCore 2+2 HSB Double Polarization Remote Mount

Note! This procedure can also be used for 2x MultiCore 1+1 HSB DP HW ready for MultiCore 2+2 HSB DP configurations.

CCDP - Protected

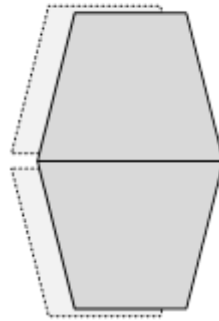

List of Items

Item	Description	Quantity	Remarks
1	IP-20C RADIO	2	
2	IP-20C OMT KIT	1	
3	IP-20C DUAL COUPLER KIT	1	
4	FLEXIBLE WG KIT	2	
5	IP-20C DC POLE MOUNT KIT	1	
6	IP-20C DC REMOTE MOUNT ADAPTOR KIT	1	From 6-13GHz
7	CIRC./CIRC. ADAPTOR	1	Per Antenna Vendor.

Required Tools

- Metric offset hexagon key set
- Metric wrench key set
- Phillips #1, #2 screwdriver

6.6.1 Common Installation

- 1 Prior to the installation, follow the antenna manufacturer's instructions to use the circular adaptor. (Remove the existing rectangular transition, swap the O-ring, and install the circular transition instead.)



- 2 Connect the OMT Kit to the antenna and secure it with four screws. Verify the existence of the O-ring.

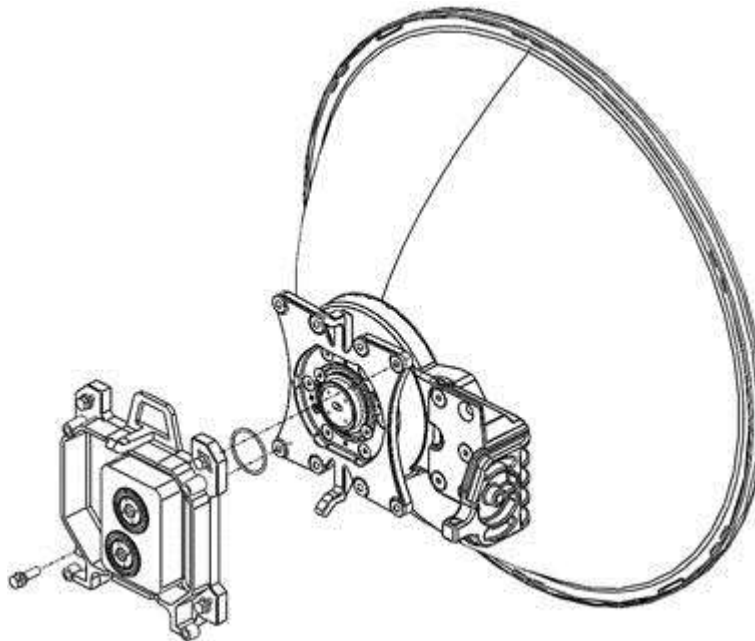

- 3 Mount and tighten the O-ring and the Flexible WG to IP-20C OMT ports using the four screws supplied with the Flexible WG kit.

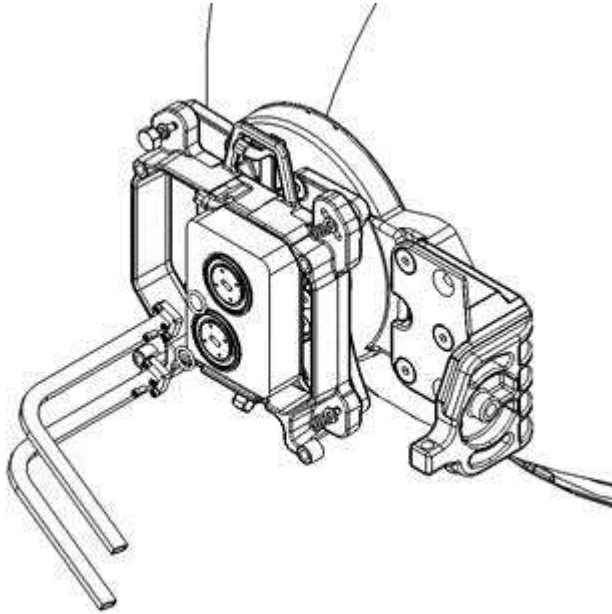

- 4 Connect the protection signaling cable between the management ports of both units. For additional instructions on preparing and connecting this cable, refer to *Preparing a MIMO/Protection Signaling Cable* on page 62.

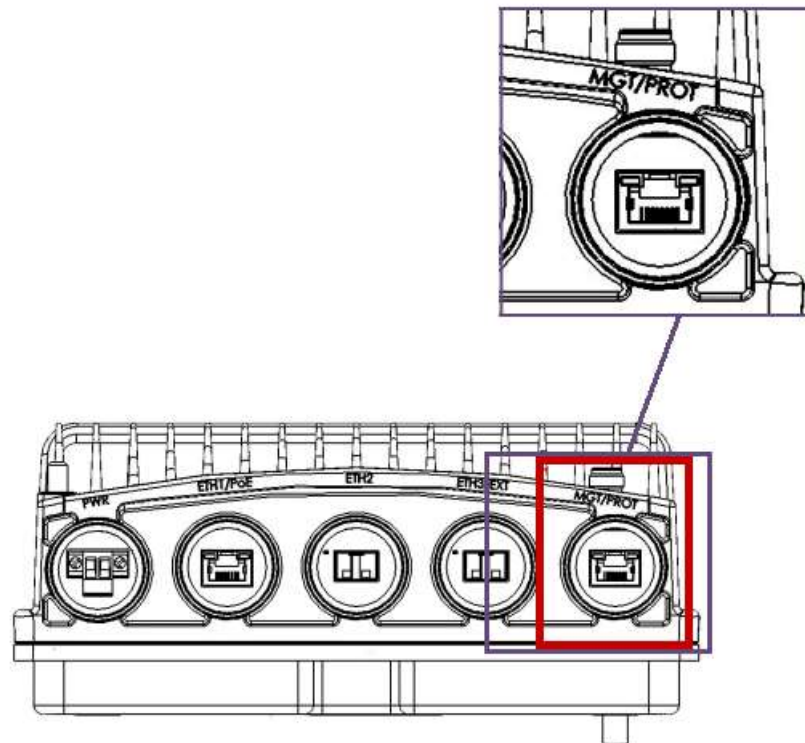

6.6.2 6-13 GHz

- 1 Mount and tighten the IP-20C Remote Mount Adaptor plate (supplied in IP-20C Adaptor Remote Mount kit) to the IP-20C Pole Mount using the four flat screws supplied with the IP-20C Adaptor Remote Mount kit.

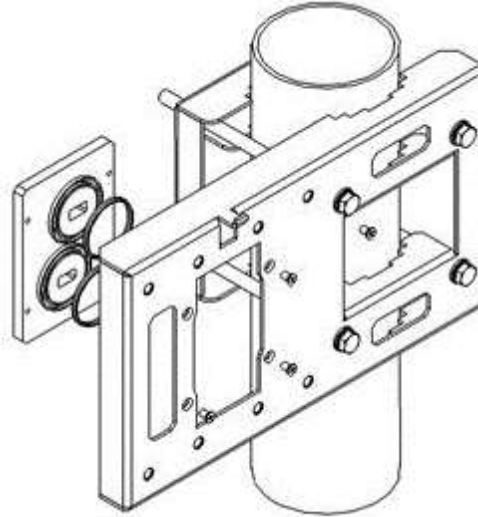

- 2 Mount and tighten the IP-20C Dual Coupler to the IP-20C Pole Mount using the four screws and washers that are supplied with the IP-20C Dual Coupler kit. Pay attention that the O-rings are mounted on the IP-20C Remote Mount Adaptor.

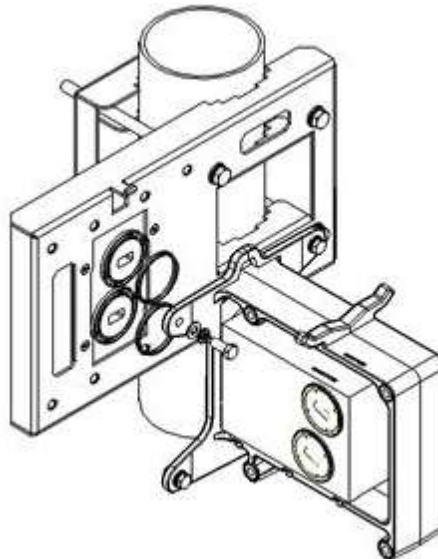

- 3 Mount and tighten the IP-20C radios on each side of the IP-20C Dual Coupler using the screws assembled on IP-20C radio. Pay attention that the O-rings are correctly assembled on the radio port of the IP-20C Dual coupler.

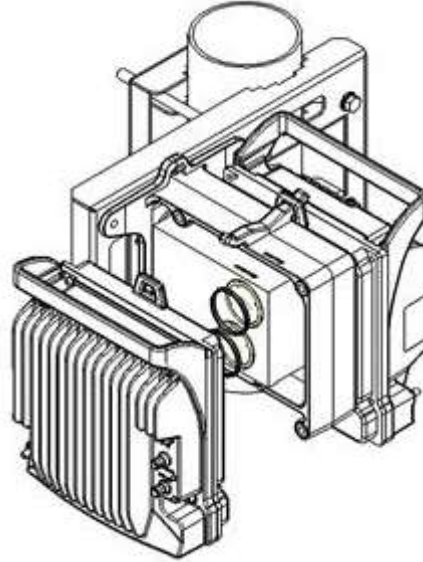

- 4 Connect both Flexible Waveguides and Sealing Gaskets supplied with each Flexible Waveguide Kit to the IP-20C Dual Coupler antenna ports. Tighten the screws and washers supplied with the Flexible Waveguide Kit.

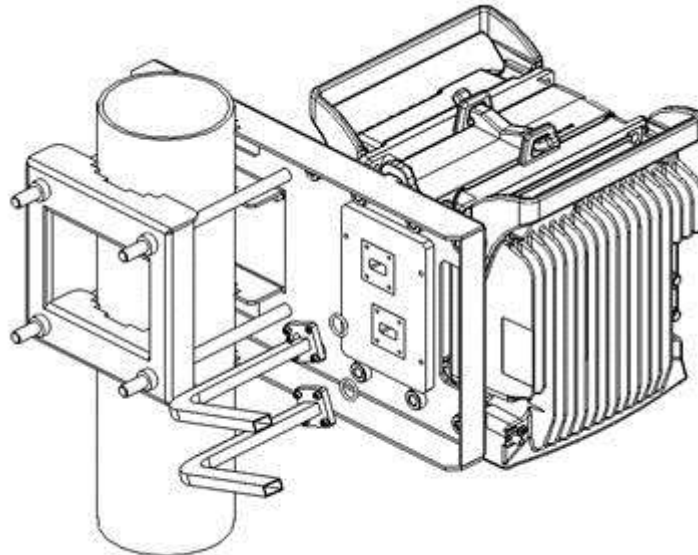

6.6.3 15-42 GHz

- 1 Mount and tighten the IP-20C Dual Coupler to IP-20C DC Pole Mount using the four screws and washers supplied with IP-20C Dual Coupler kit.

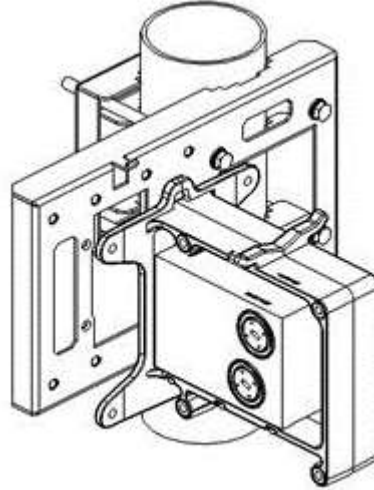

- 2 Mount and tighten the IP-20C radios on each side of the IP-20C Dual Coupler using the screws assembled on Ip-20C radio. Pay attention that the O-rings are correctly assembled on the radio port of the IP-20C Dual coupler.

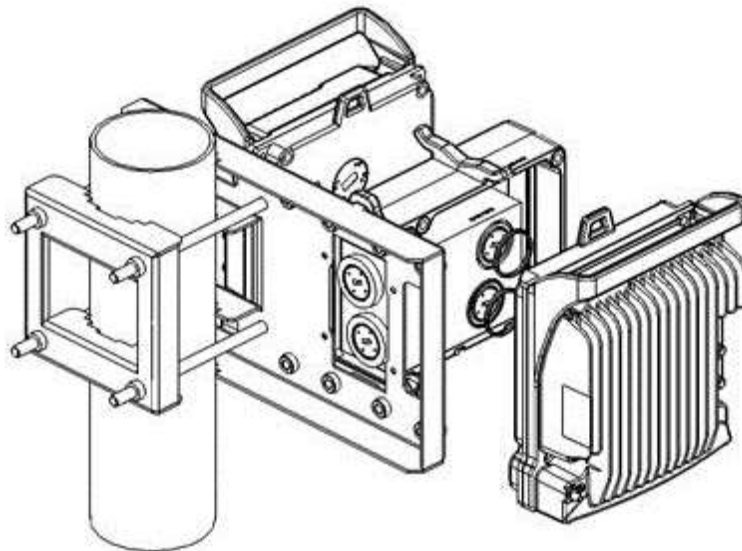

- 3 Mount the O-ring and the Flexible WG to IP-20C Dual Coupler ports using the four screws supplied with the Flexible WG kit.

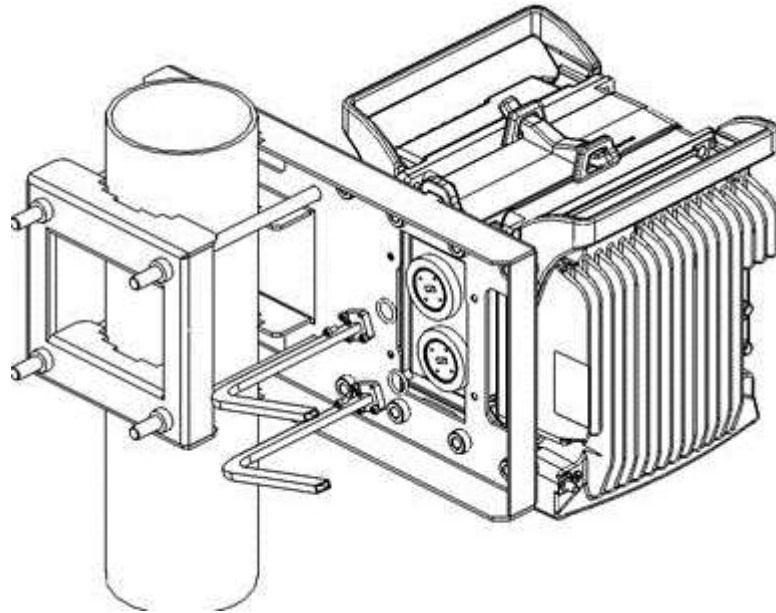

6.7 MultiCore 2+2 HSB Single Polarization Direct Mount

Note! This procedure can also be used for 2 x MultiCore 1+1 HSB SP HW ready for MultiCore 2+2 HSB SP configurations.

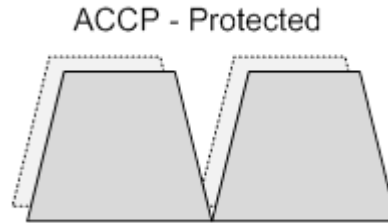

List of Items

Item	Description	Quantity	Remarks
1	IP-20C RADIO	2	
2	IP-20C SPLITTER KIT	1	
3	DUAL COUPLER KIT	1	

Required Tools

- Metric offset hexagon key set
- Metric wrench key set
- Phillips #1 screwdriver

Procedure

- 1 Adjust the twist on the Splitter Kit. Perform one of the procedures below, according to the required polarization (horizontal or vertical).

Horizontal polarization: Locate the holes above and below the letter “H” on the pins and fasten the two screws.

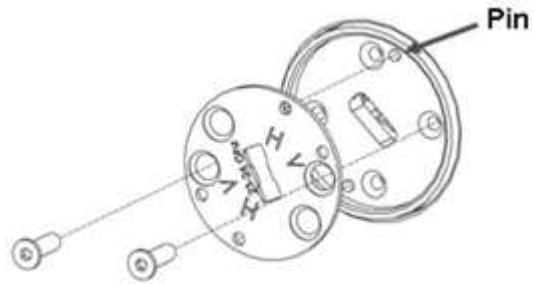

Vertical polarization: Locate the holes above and below the letter “V” on the pins and fasten the two screws.

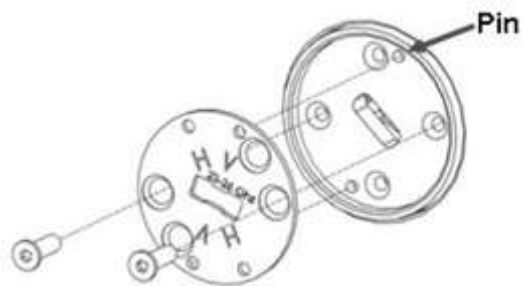

- 2 Mount the Splitter Kit on the antenna using four M8 screws and washers and tighten the screws.

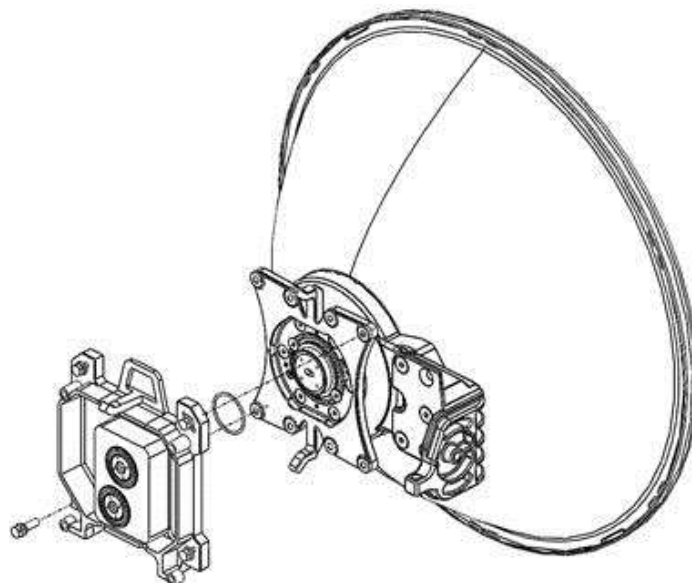

- 3 Connect the IP-20C Dual Coupler Kit to the IP-20C Splitter Kit using four M8 screws and washers and tighten the screws.

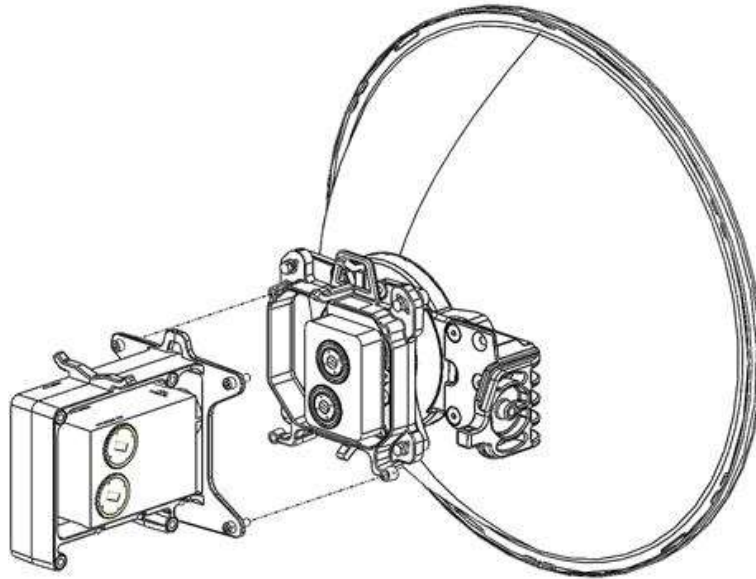

- 4 Connect the IP-20C DC radio unit to both sides of the Dual Coupler Kit using the supplied captive screws and washers and tighten the screws.

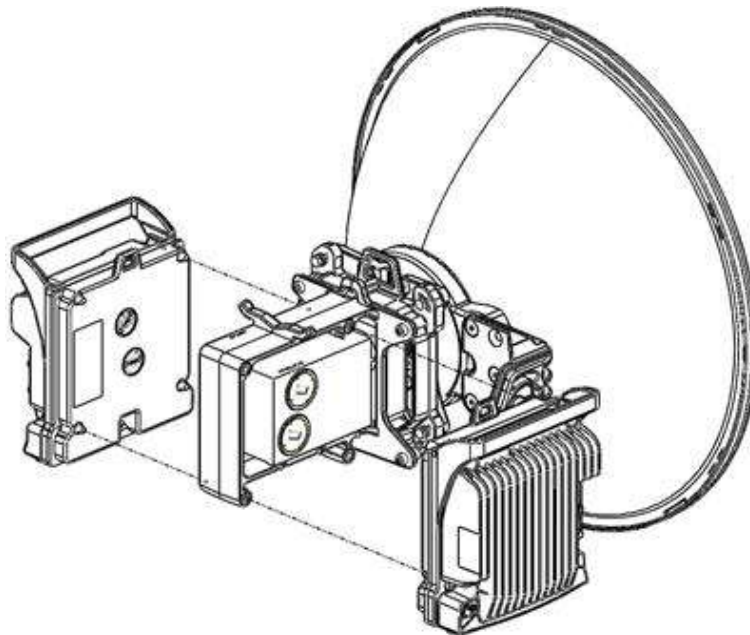

- 5 Connect the protection signaling cable between the management ports of both units. For additional instructions on preparing and connecting this cable, refer to *Preparing a MIMO/Protection Signaling Cable* on page 62.

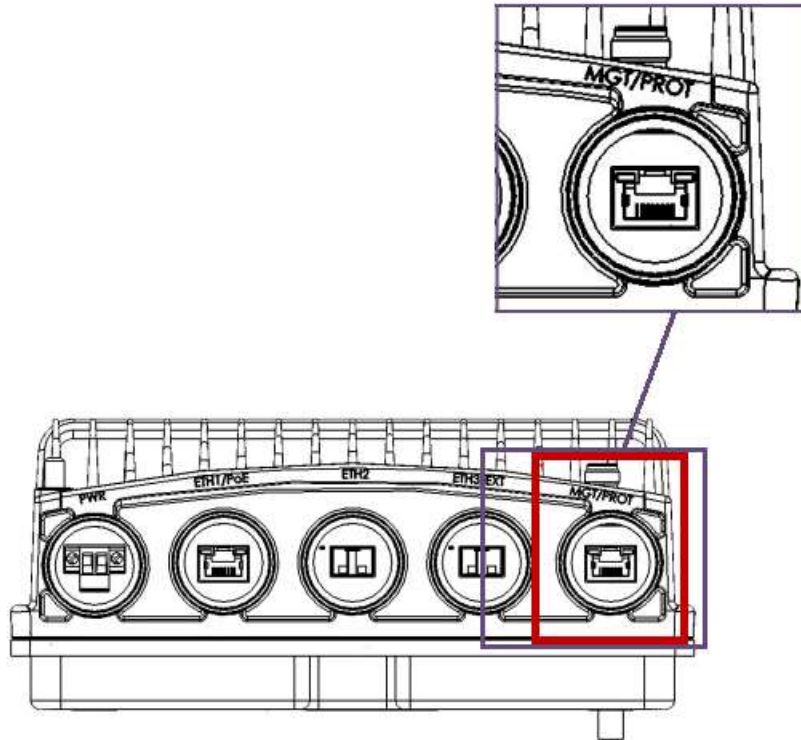

6.8 MultiCore 2+2 HSB Single Polarization Remote Mount

Note! This procedure can also be used for 2 x MultiCore 1+1 HSB SP HW ready for 2+2 HSB SP configuration.

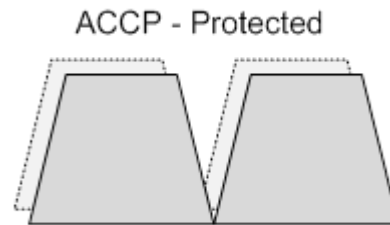

List of Items

Item	Description	Quantity	Remarks
1	IP-20C RADIO	2	
2	IP-20C SPLITTER KIT	1	
3	IP-20C DUAL COUPLER KIT	1	
4	FLEXIBLE WG KIT	2	
5	RFU-C POLE MOUNT KIT	1	
6	RFU-C REMOTE MOUNT ADAPTOR	1	From 6-13 GHz.

Required Tools

- Metric offset hexagon key set
- Metric wrench key set
- Phillips #1, #2 screwdriver

6.8.1 6-13 GHz

- 1 Mount and tighten the RFU-C Remote Mount Adaptor plate (supplied in RFU-C Adaptor Remote Mount kit) to the RFU-C Pole Mount using the four flat screws supplied with the RFU-C Adaptor Remote Mount kit.

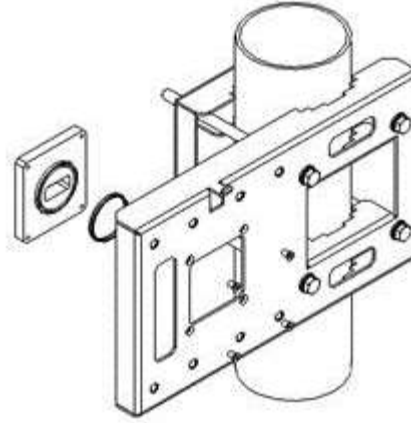

- 2 Mount and tighten the IP-20C Splitter to the RFU-C Pole Mount using the four captive screws and washers that are assembled to the IP-20C Splitter kit.

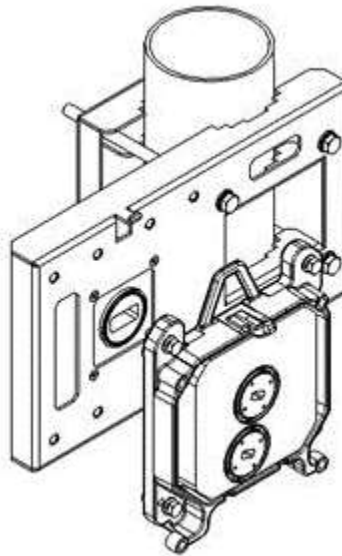

- 3 Mount and tighten the IP-20C Dual Coupler to the IP-20C Splitter using the four captive screws and washers that are supplied with the IP-20C Dual Coupler kit. Pay attention that the O-rings are mounted on the IP-20C Splitter.

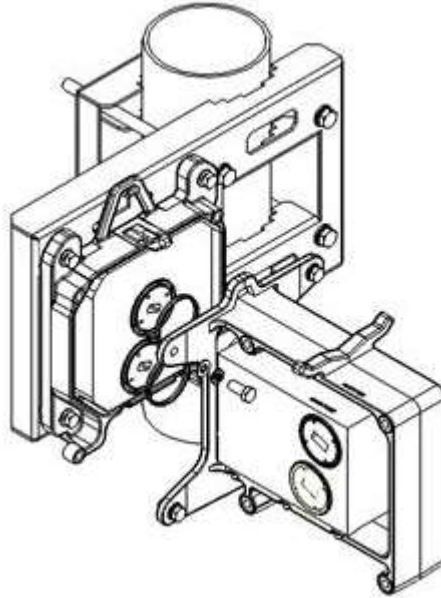

- 4 Mount and tighten the IP-20C Radio to the IP-20C Dual Coupler using the four screws and washers that are assembled to the IP-20C Radio. Pay attention that the O-rings are mounted on the IP-20C Dual Coupler.

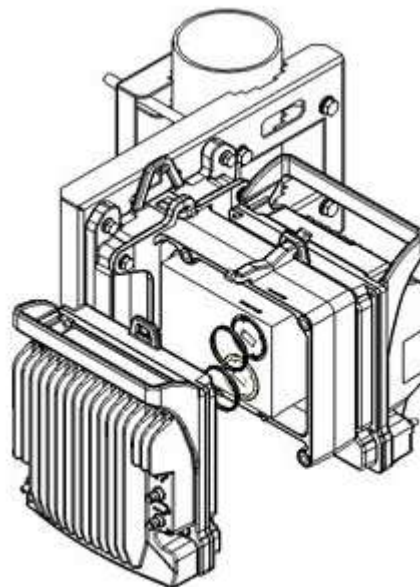

- 5 Connect the Flexible Waveguide and Sealing Gasket supplied with the Flexible Waveguide Kit to the RFU-C Adaptor plate. Tighten the four screws supplied with the Flexible Waveguide Kit.

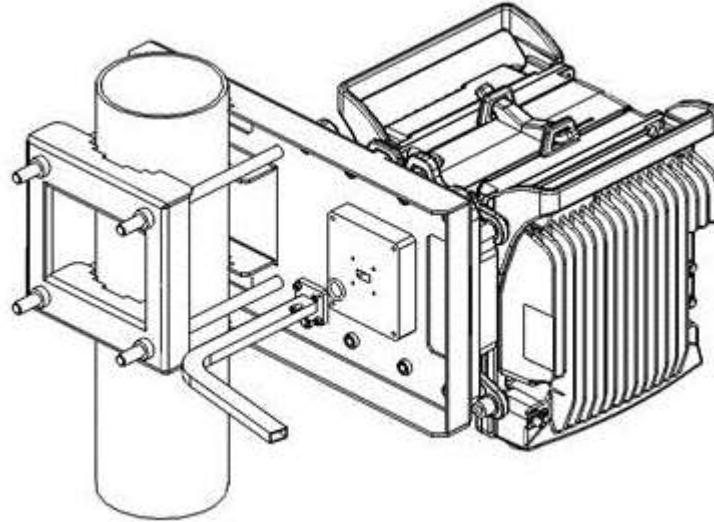

- 6 Connect the protection signaling cable between the management ports of both units. For additional instructions on preparing and connecting this cable, refer to *Preparing a MIMO/Protection Signaling Cable* on page 62.

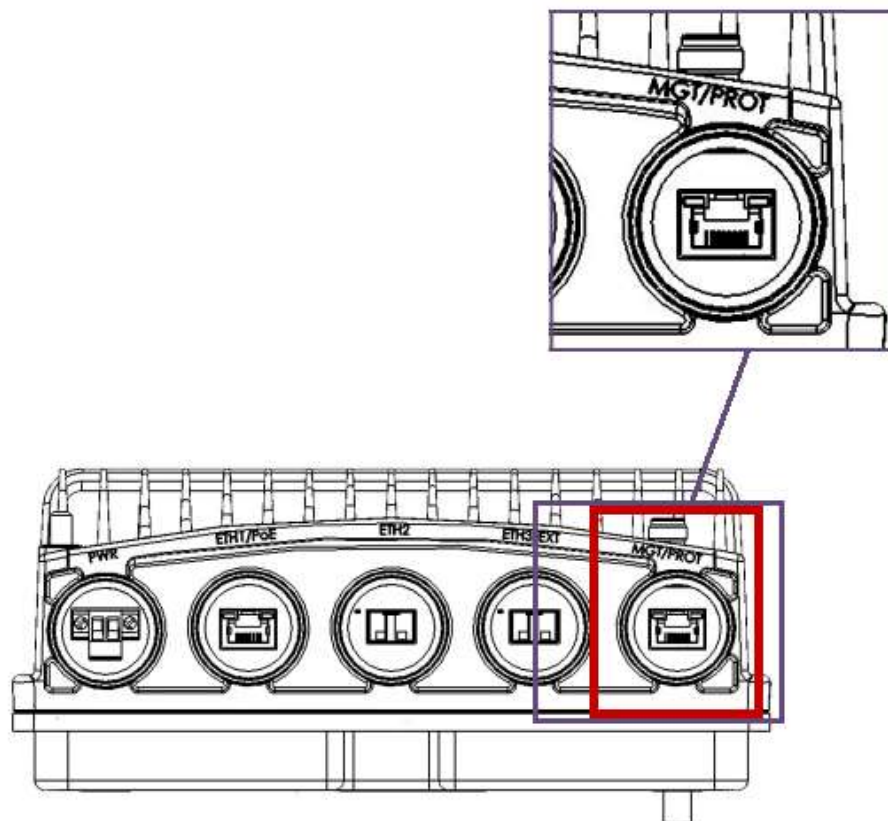

6.8.2 15-42 GHz

- 1 Loosen the two screws, and remove the twist plate from the IP-20C Splitter.

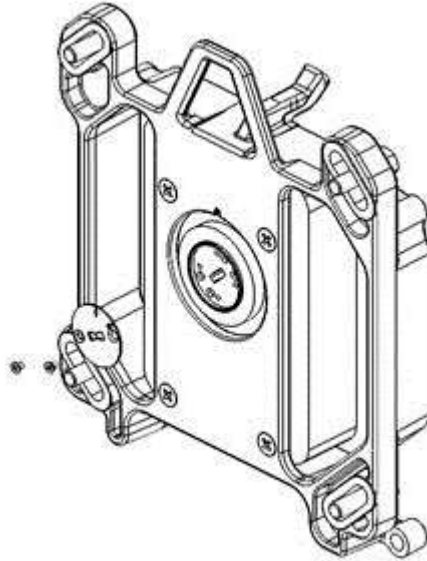

- 2 Mount and tighten the IP-20C Splitter to the RFU-C Pole Mount using the four captive screws and washers that are assembled to the IP-20C Splitter kit.

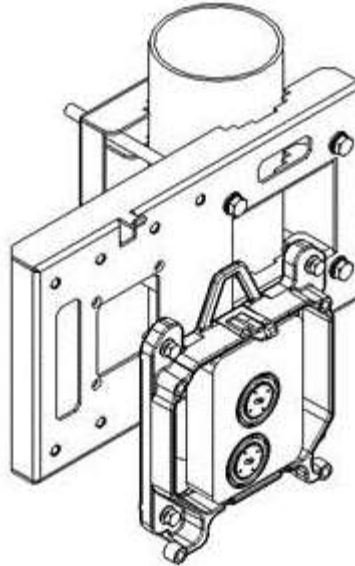

- 3 Mount and tighten the IP-20C Dual Coupler to the IP-20C Splitter using the four captive screws and washers that are supplied with the IP-20C Dual Coupler kit. Pay attention that the O-rings are mounted on the IP-20C Splitter.

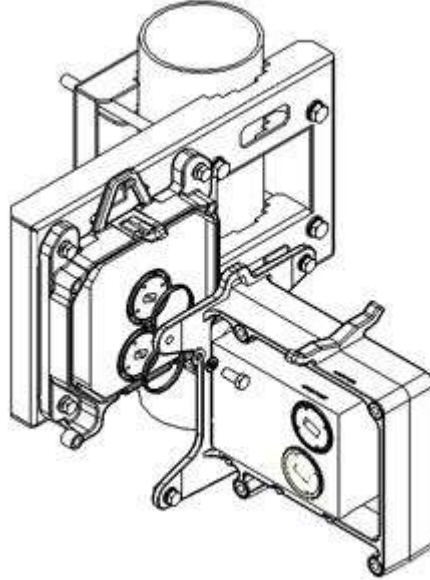

- 4 Mount and tighten the IP-20C Radio to the IP-20C Dual Coupler using the four screws and washers that are assembled to the IP-20C radio. Pay attention that the O-rings are mounted on the IP-20C Dual Coupler.

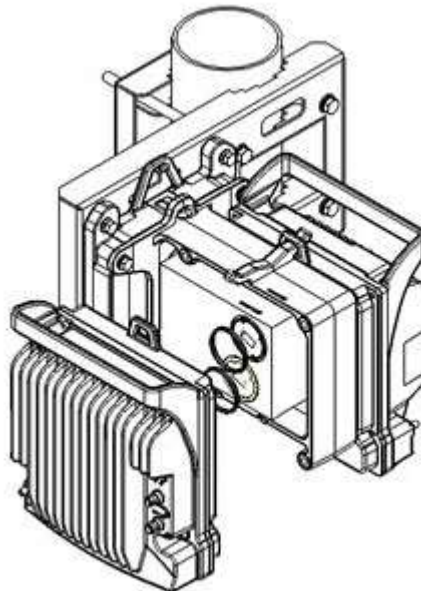

- 5 Connect the Flexible Waveguide and Sealing Gasket supplied with the Flexible Waveguide Kit to the IP-20C Dual Coupler antenna port. Tighten the four screws supplied with the Flexible Waveguide kit.

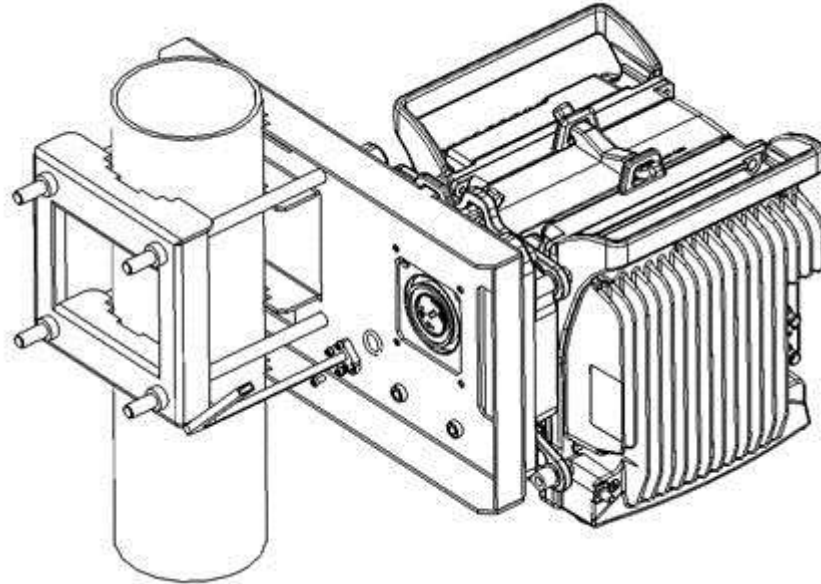

- 6 Connect the protection signaling cable between the management ports of both units. For additional instructions on preparing and connecting this cable, refer to *Preparing a MIMO/Protection Signaling Cable* on page 62.

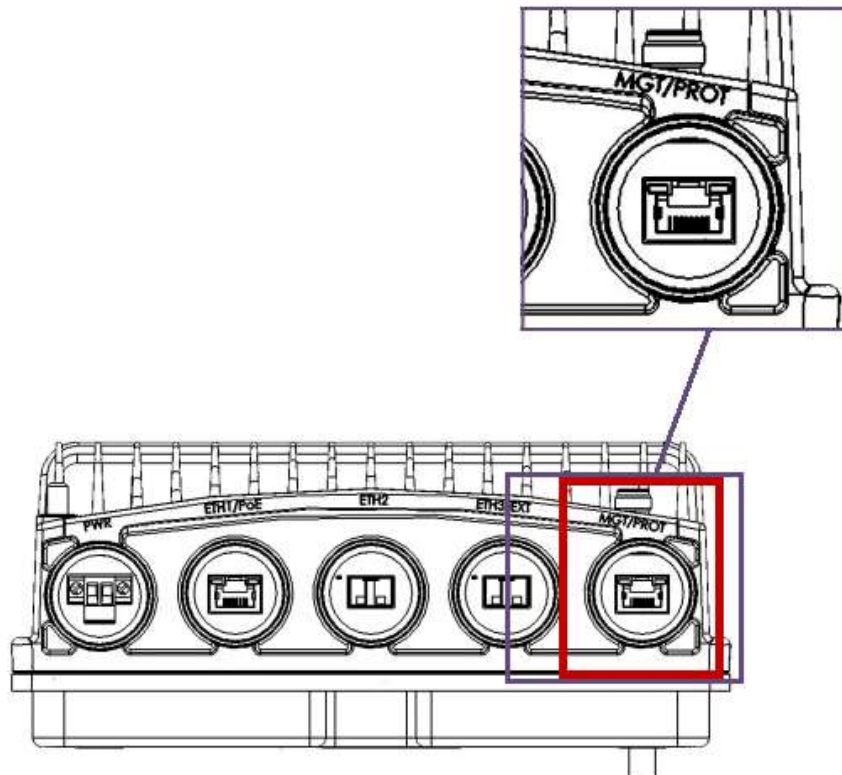

6.9 2 x MultiCore 2+0 Dual Polarization Direct Mount

Note! This procedure can also be used for MultiCore 2+0 DP HW ready for 2 x MultiCore 2+0 DP configurations.

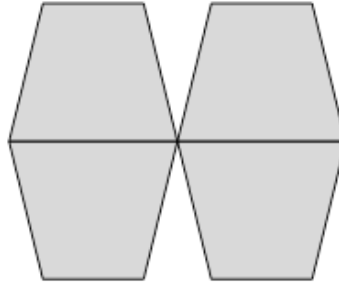

List of Items

Item	Description	Quantity	Remarks
1	IP-20C RADIO	2	
2	IP-20C OMT KIT	1	
3	IP-20C DUAL COUPLER or SPLITTER KIT	1	
4	CIRC./CIRC. ADAPTOR	1	Per Antenna Vendor

Required Tools

- Metric offset hexagon key set
- Metric wrench key set

Procedure

- 1 Prior to the installation, follow the antenna manufacturer's instructions to use the circular adaptor. (Remove the existing rectangular transition, swap the O-ring, and install the circular transition instead.)



- 2 Connect the IP-20C OMT Kit to the antenna and secure it with four screws. Verify existence of the O-ring.

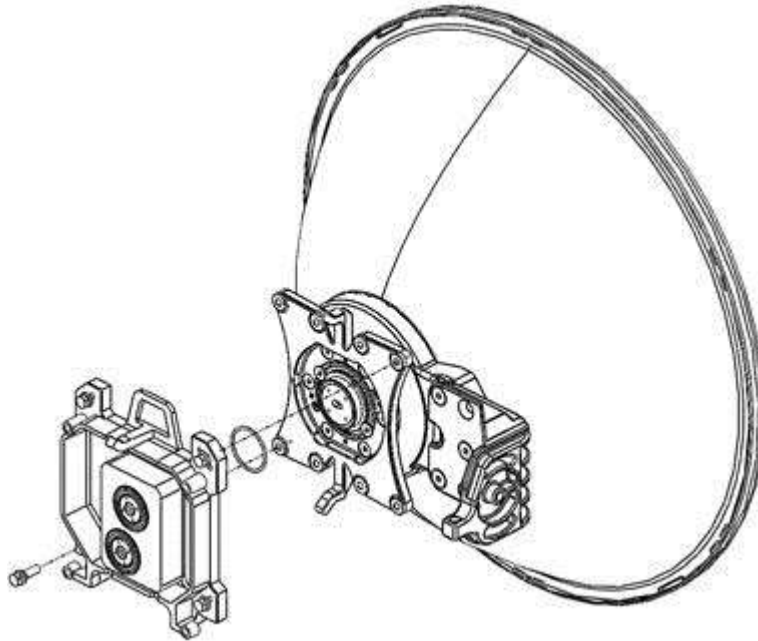

- 3 Connect the IP-20C Dual Coupler Kit to the OMT Kit using four M8 screws and washers, and tighten the screws.

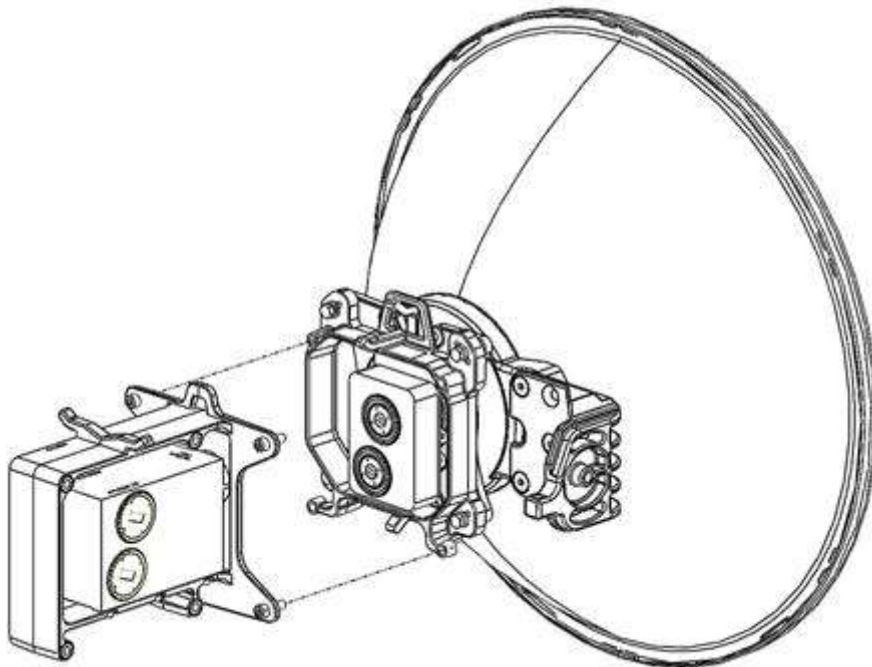

- 4 Mount and tighten the IP-20C DC radio unit to both sides of the Dual Coupler Kit using the supplied captive screws and washers. Pay attention that the O-rings are correctly mounted on the radio ports of the IP-20C Dual Coupler.

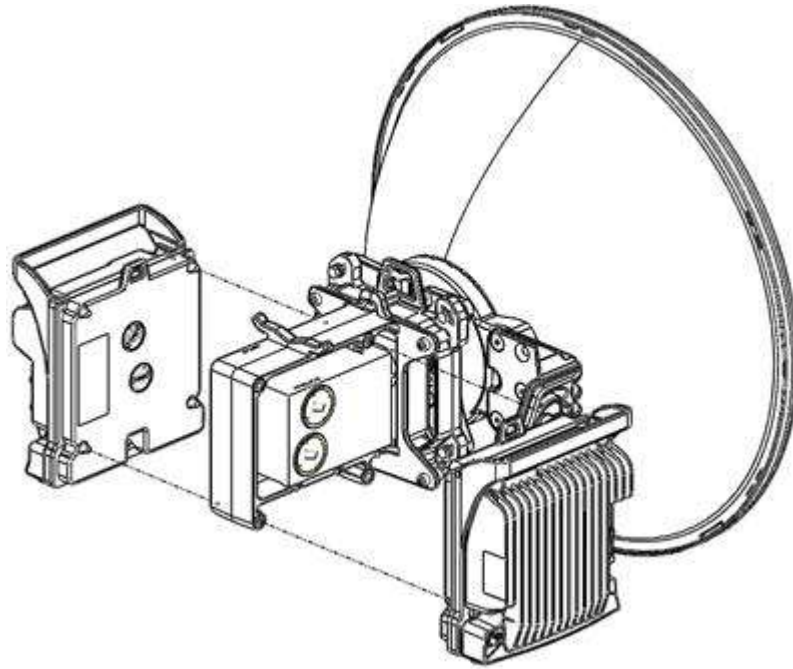

6.10 2 x MultiCore 2+0 Dual Polarization Remote Mount

Note! This procedure can also be used for 2 x MultiCore 1+0 DP HW ready for 2 x MultiCore 2+0 DP configurations.

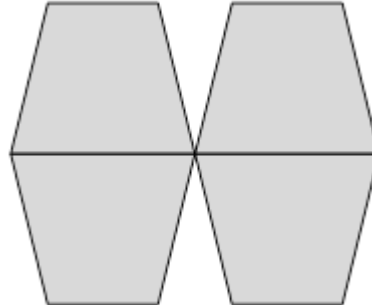

List of Items

Item	Description	Quantity	Remarks
1	IP-20C RADIO	2	
2	IP-20C OMT KIT	1	
3	IP-20C DUAL COUPLER OR DUAL SPLITTER KIT	1	
4	FLEXIBLE WG KIT	2	
5	IP-20C DC POLE MOUNT KIT	1	
6	IP-20C DC REMOTE MOUNT ADAPTOR KIT	1	From 6-13GHz
7	CIRC./CIRC. ADAPTOR	1	Per Antenna Vendor

Required Tools

- Metric offset hexagon key set
- Metric wrench key set
- Phillips #1, #2 screwdriver

6.10.1 Common Installation Procedure

- 1 Prior to the installation, follow the antenna manufacturer's instructions to use the circular adaptor. (Remove the existing rectangular transition, swap the O-ring, and install the circular transition instead.)



- 2 Connect the OMT Kit to the antenna and secure it with four screws. Verify the existence of the O-ring.

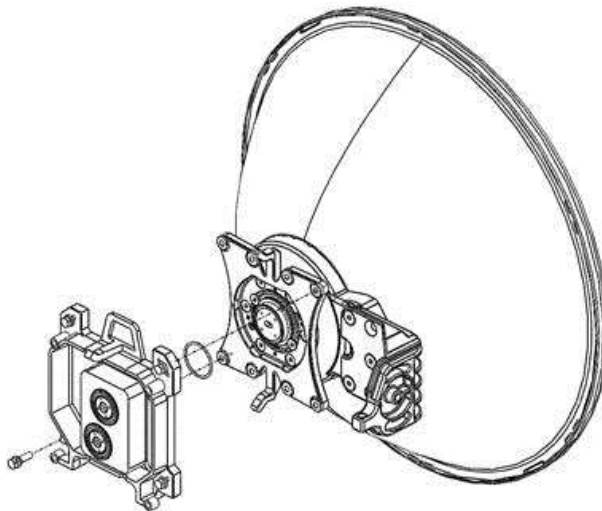

- 3 Mount and tighten the O-ring and the Flexible WG to IP-20C OMT ports using the four screws supplied with the Flexible WG kit.

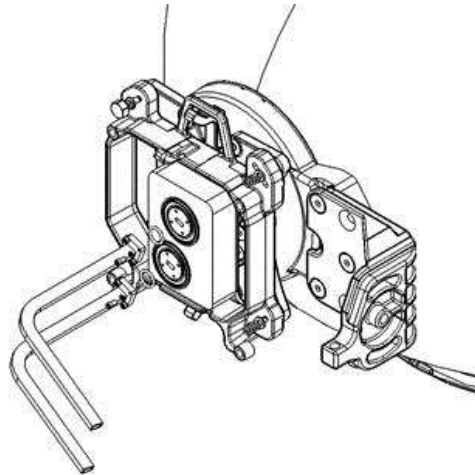

6.10.2 6-13 GHz

- 1 Mount and tighten the IP-20-C Remote Mount Adaptor plate (supplied in IP-20C Adaptor Remote Mount kit) to the IP-20C Pole Mount using the four flat screws supplied with the IP-20C Adaptor Remote Mount kit.

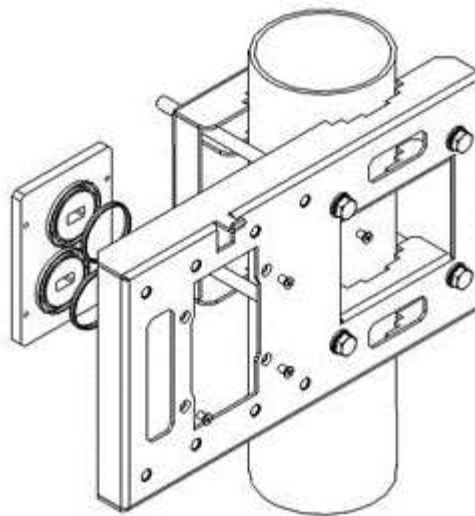

- 2 Mount and tighten the IP-20C Dual Coupler to the IP-20C Pole Mount using the four screws and washers that are supplied with the IP-20C Dual Coupler kit. Pay attention that the O-rings are mounted on the IP-20C Remote Mount Adaptor.

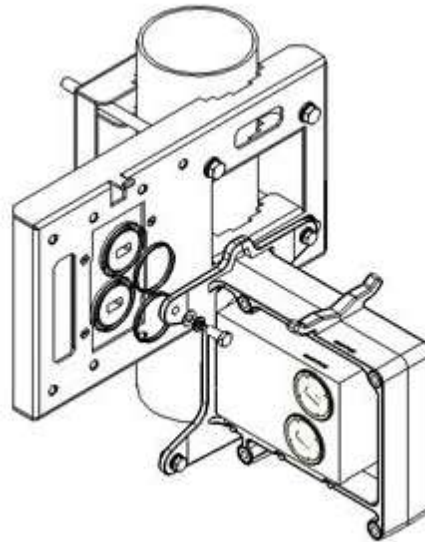

- 3 Mount and tighten the IP-20C radios on each side of the IP-20C Dual Coupler using the screws assembled on IP-20C radio. Make sure that the O-rings are correctly assembled on the radio port of the IP-20C Dual Coupler.

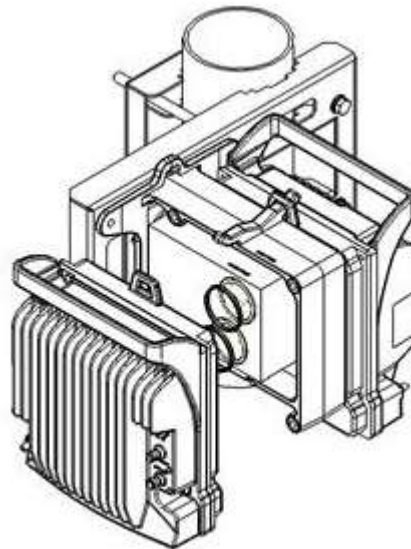

- 4 Connect both Flexible Waveguides and Sealing Gaskets supplied with each Flexible Waveguide Kit to the IP-20C Dual Coupler antenna ports. Tighten the screws and washers supplied with the Flexible Waveguide Kit.

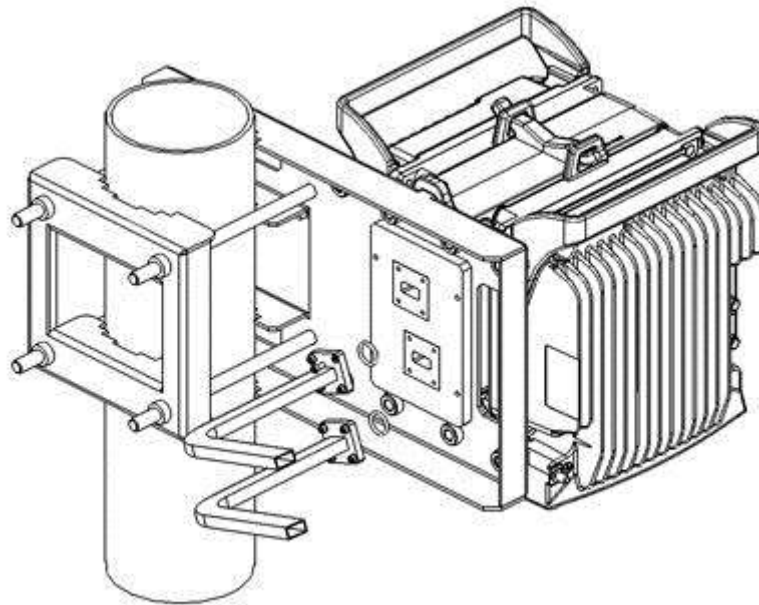

6.10.3 15-42 GHz

- 1 Mount and tighten the IP-20C Dual Coupler to IP-20C DC Pole Mount using the four screws and washers supplied with IP-20C Dual Coupler kit.

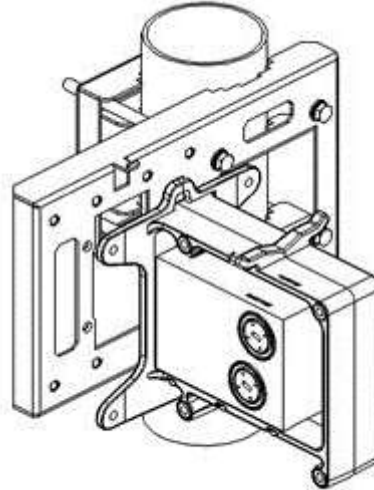

- 2 Mount and tighten the IP-20C radios on each side of the IP-20C Dual Coupler using the screws assembled on IP-20C radio. Pay attention that the O-rings are correctly assembled on the radio port of the IP-20C Dual Coupler.

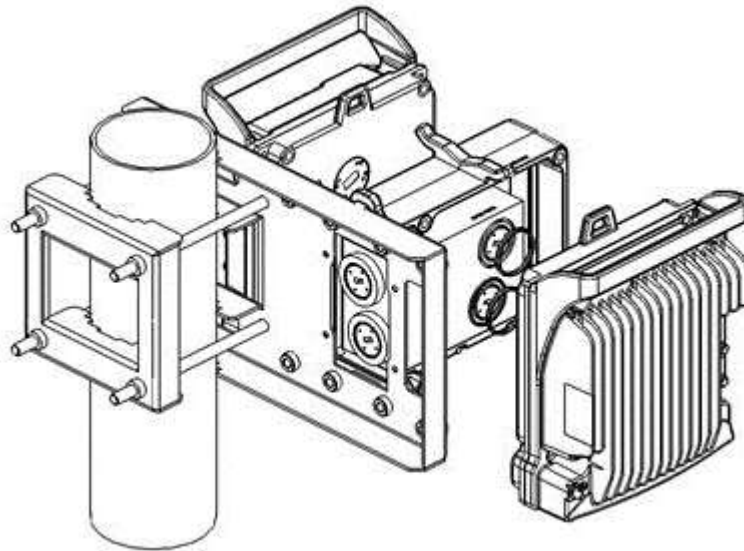

- 3 Mount the O-ring and the Flexible WG to IP-20C Dual Coupler ports using the four screws supplied with the Flexible WG kit.

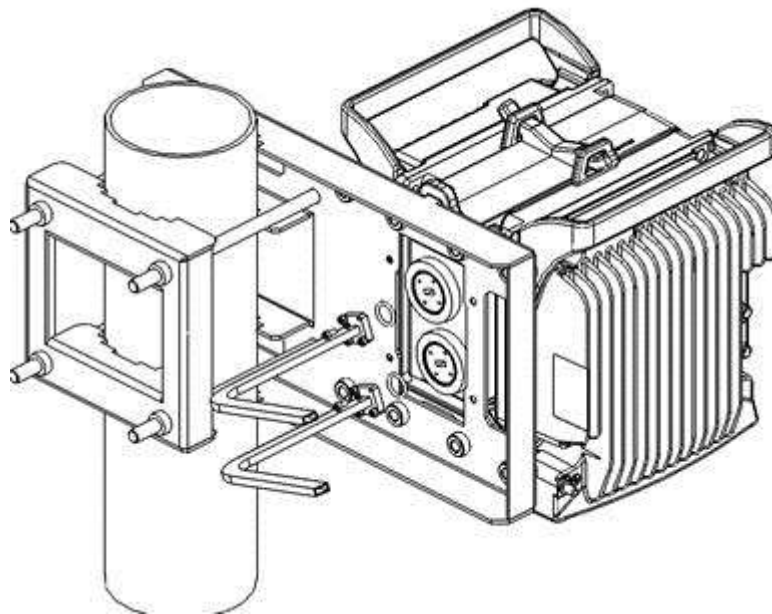

6.11 2 x MultiCore 2+0 Single Polarization Direct Mount

Note! This procedure can also be used for 2 x MultiCore 1+0 SP HW ready for 2 x MultiCore 2+0 SP configurations.

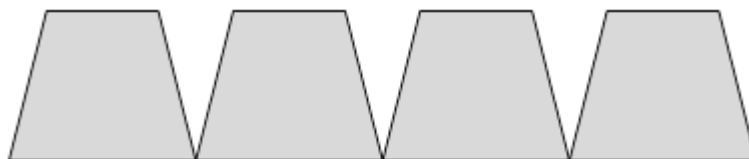

List of Items

Item	Description	Quantity	Remarks
1	IP-20C RADIO	2	
2	IP-20C Splitter Kit	1	
3	IP-20C Dual Splitter Kit	1	

Required Tools

- Metric offset hexagon key set
- Metric wrench key set
- Phillips #1 screwdriver

Procedure

- 1 Adjust the twist on the IP-20C Splitter Kit. Perform one of the procedures below according to the required polarization

Horizontal polarization: Locate the holes above and below the letter “H” on the pins and fasten the two screws.

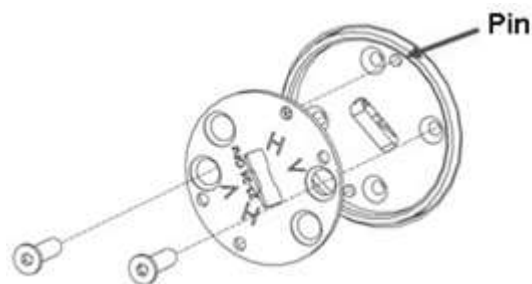

Vertical polarization: Locate the holes above and below the letter “V” on the pins and fasten the two screws.

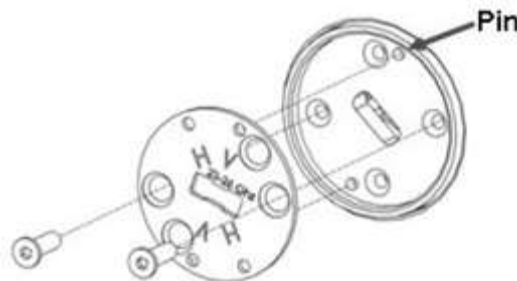

- 2 Mount the Splitter Kit on the antenna using four M8 screws and washers and tighten the screws.

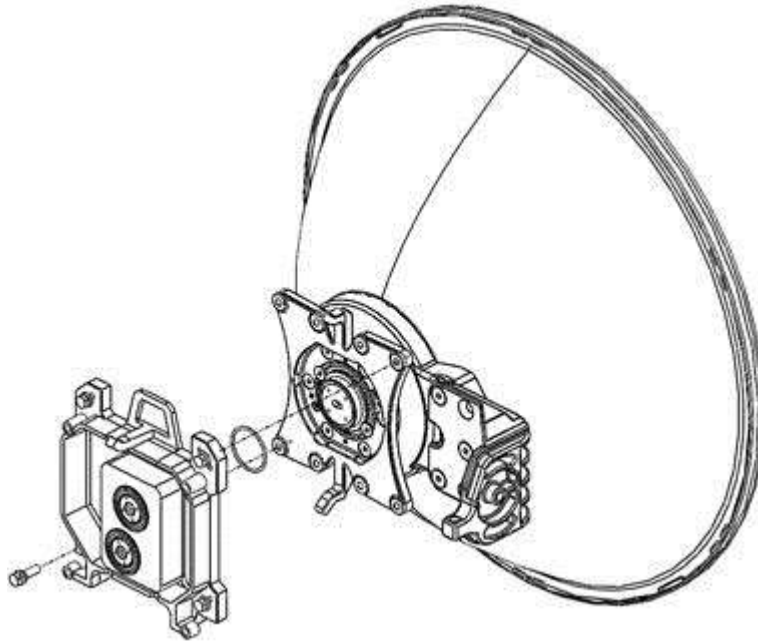

- 3 Connect the IP-20C Dual Coupler Kit to the IP-20C Splitter Kit using four M8 screws and washers and tighten the screws.

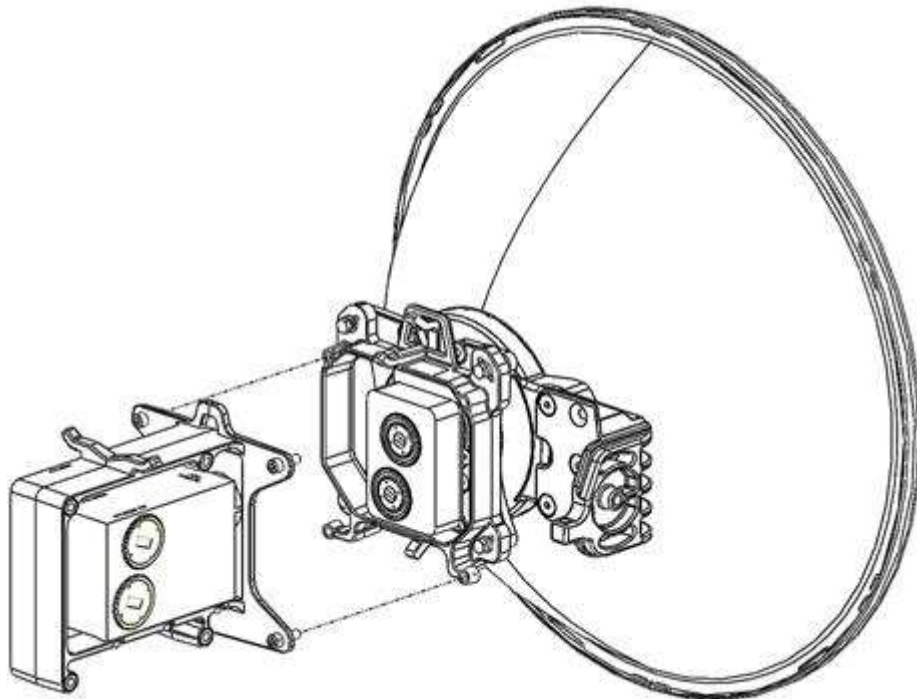

- 4 Connect the IP-20C DC radio unit to both sides of the Dual Coupler Kit using the supplied captive screws and washers and tighten the screws.

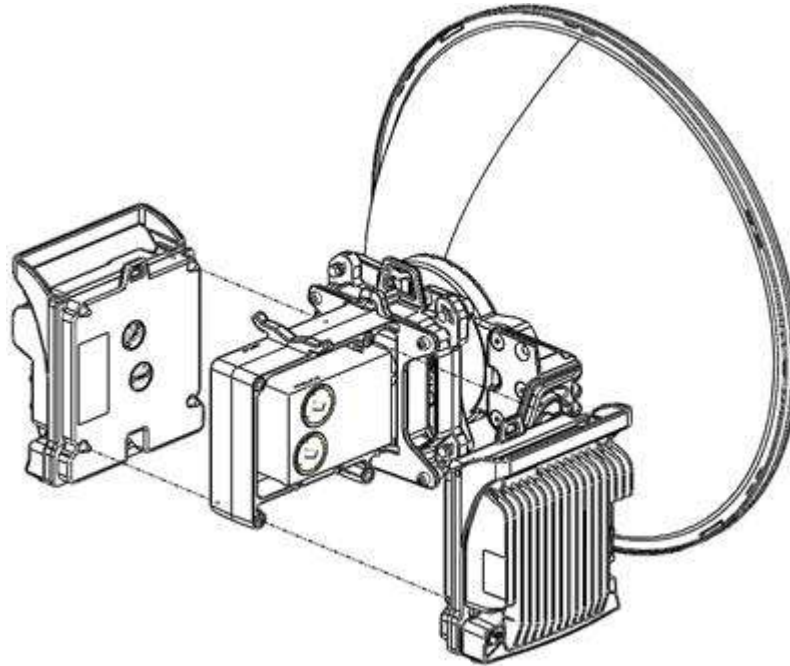

6.12 2x2 LoS MIMO Direct Mount

Note! This procedure can also be used for 1+0 SD configurations.

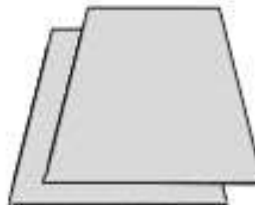

List of Items

Item	Description	Quantity	Remarks
1	IP-20C Radio	1	
2	IP-20C Dual Core Kit	1	
3	Flexible WG Kit	1	Optional
4	Coax to WG Kit	1	Optional

Required Tools

- Metric offset hexagon key set
- Phillips #1, #2 screwdriver

Procedure

- 1 Adjust the twist on the dual core kit according to the required polarization.

Important: Make sure the polarization mounting direction of the twist to the dual core is according to the antenna polarization.

- For horizontal polarization, locate the holes above and below the letter “H” on the pins and fasten the two screws.

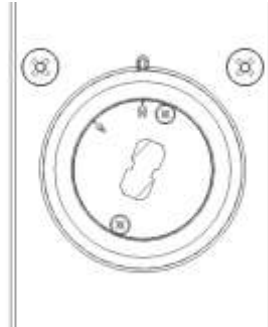

- For vertical polarization, locate the holes above and below the letter “V” on the pins and fasten the two screws.

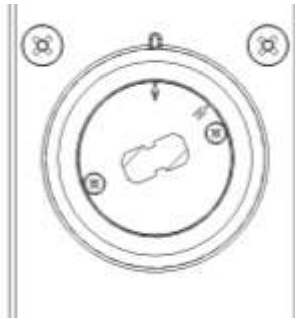

- 2 If not required, remove the plate assembled to the bended part of the dual core kit.

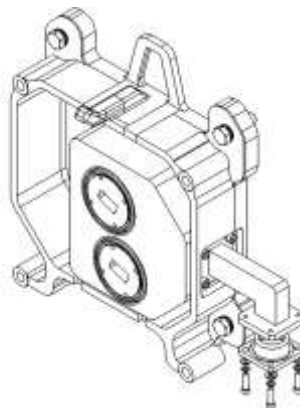

- 3 Mount and tighten the IP-20C dual core kit on the antenna using the four M8 screws and washers.

Important: Verify that the O-ring is properly mounted between the antenna transition and the dual core.



- 4 Connect the IP-20C radio to the IP-20C dual core kit using four M8 screws and washers and tighten the screws.

Important: Verify that the O-rings are properly mounted between the dual core and the radio.

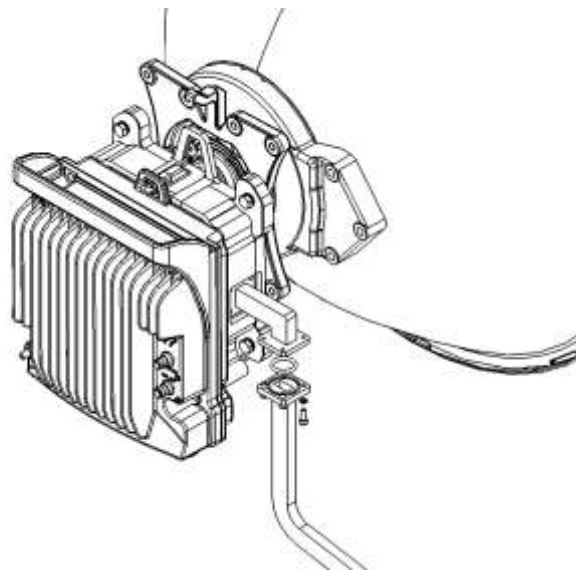

- 5 You can switch the orientation of the dual core flange connection by removing screws and rotating the bended part. Place back O-ring and tighten back screws.

Important: Verify that the O-rings are properly mounted between the dual core and the Coax to WG flange.

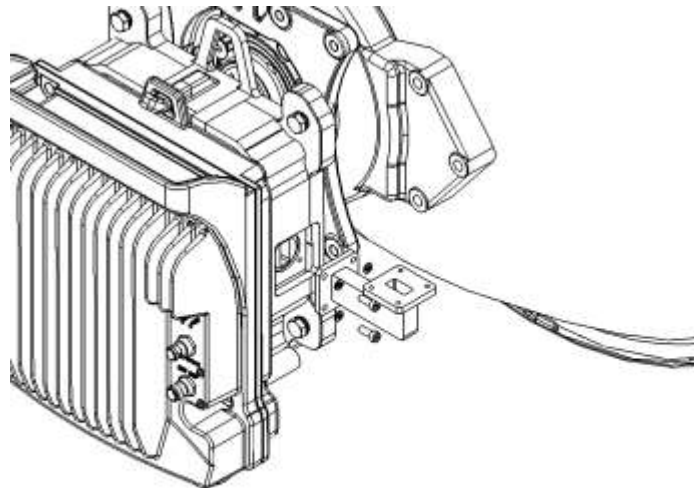

- 6 Connect the flexible waveguide to the IP-20C dual core kit using O-ring, screws and washers supplied with flexible waveguide kit and tighten the screws.

Important: Verify that the O-rings are properly mounted between the dual core and the flexible waveguide flange.

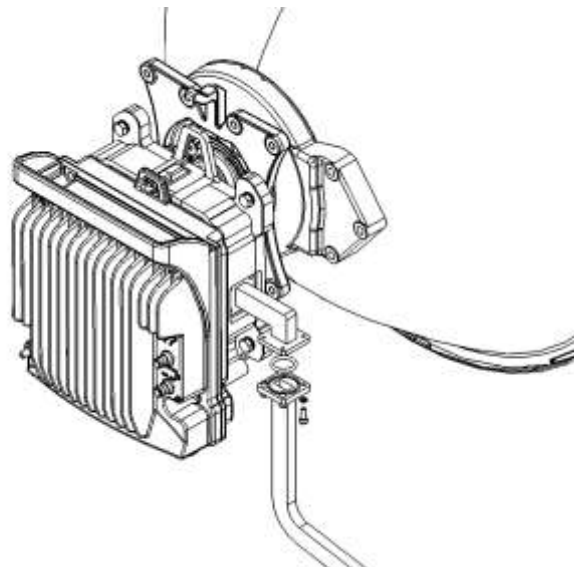

- 7 You can also connect the dual core flange to coax to WG adapter supplied separately. Place O-ring and tighten screws and washers supplied with Coax to WG adapter kit.

Important: Verify that the O-rings are properly mounted between the dual core and the Coax to WG flange.

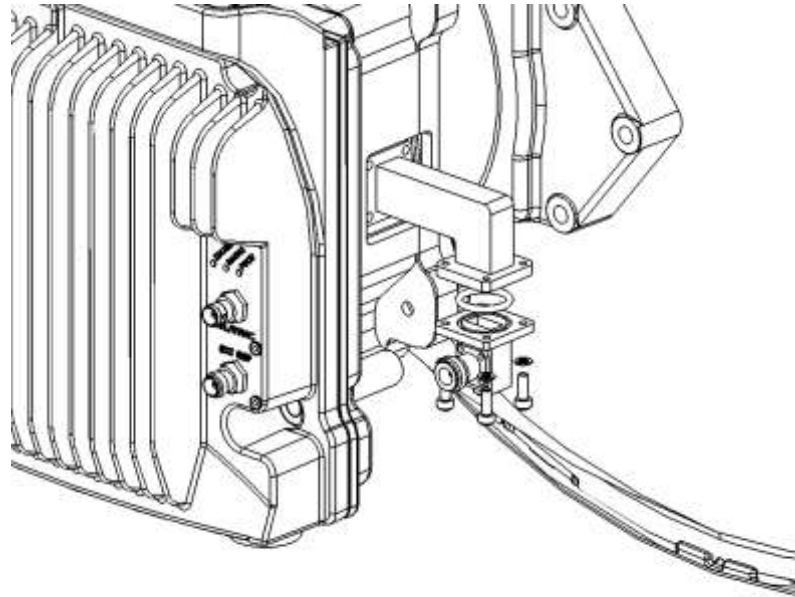

6.13 2x2 LoS MIMO Remote Mount

Note! This procedure can also be used for 1+0 SD configurations.

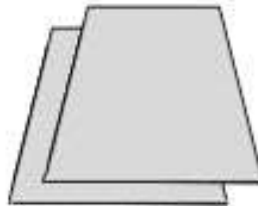

List of Items

Item	Description	Quantity	Remarks
1	IP-20C RADIO	1	
2	IP-20C REMOTE MOUNT ADAPTOR KIT	1	From 6-13GHz

Required Tools

- Metric offset hexagon key set
- Metric wrench key set

6.13.1 For 6-13 GHz

- 1 Mount and tighten the IP-20-C Remote Mount Adaptor plate (supplied in IP-20C Adaptor Remote Mount kit) to the IP-20C Pole Mount using the four flat screws supplied with the IP-20C Adaptor Remote Mount kit.

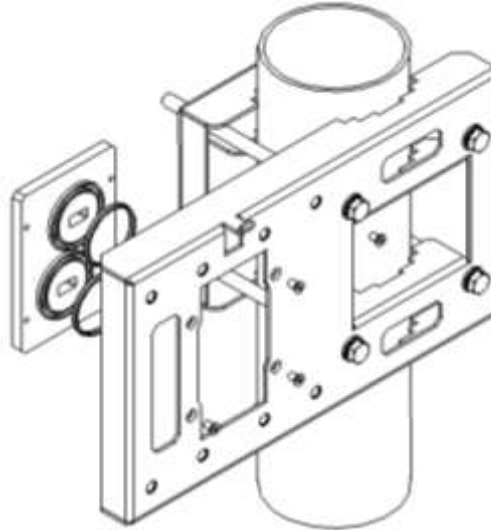

- 2 Mount and tighten the IP-20C Radio to the IP-20C Pole Mount using the four captive screws and washers that are supplied with the IP-20C Radio. Pay attention that the O-rings are mounted on the IP-20C Remote Mount Adaptor.

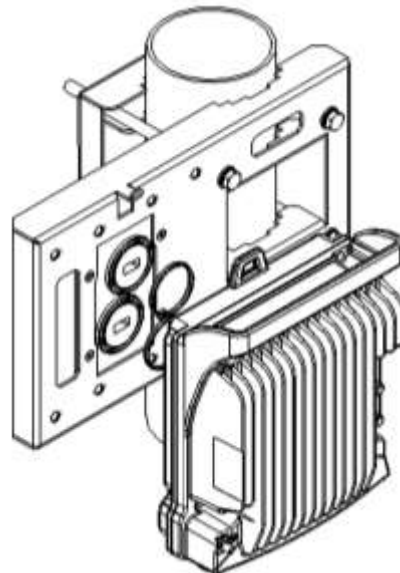

- 3 Mount and tighten both Flexible WGs with their O-ring to the IP-20C Remote Mount Adaptor ports using the four screws supplied with each Flexible WG kit.

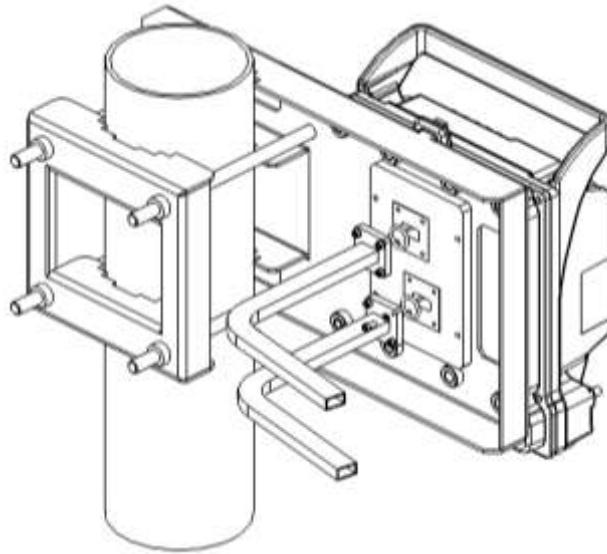

6.13.2 15-42GHz

- 1 Mount and tighten the IP-20C radio to the IP-20C DC Pole Mount using the four screws assembled on the IP-20C radio.

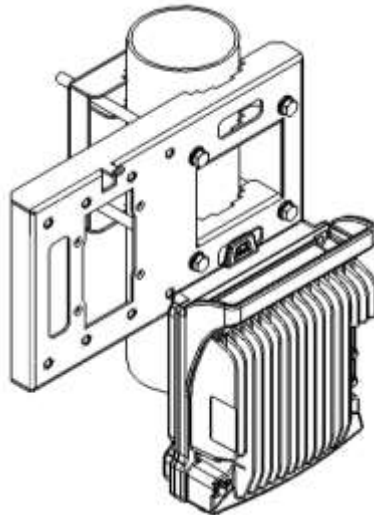

- 2 Mount and tighten the O-ring and the Flexible WG to IP-20C radio ports using the four screws supplied with the Flexible WG kit.

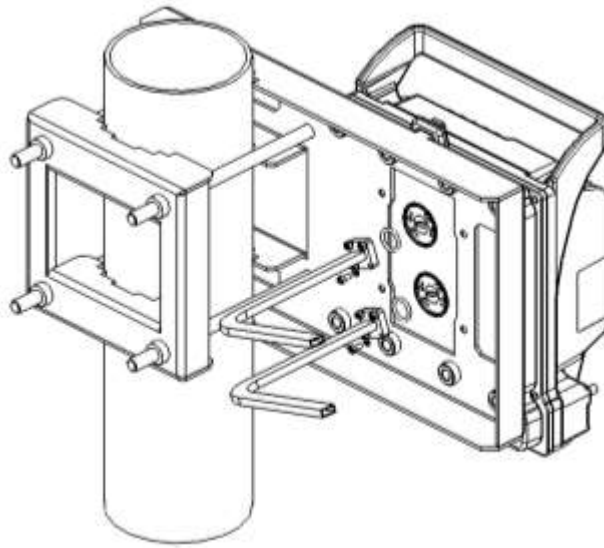

- 3 Mount and tighten the O-ring and flexible WG to both antenna ports using the four screws supplied with the flexible WG kit.

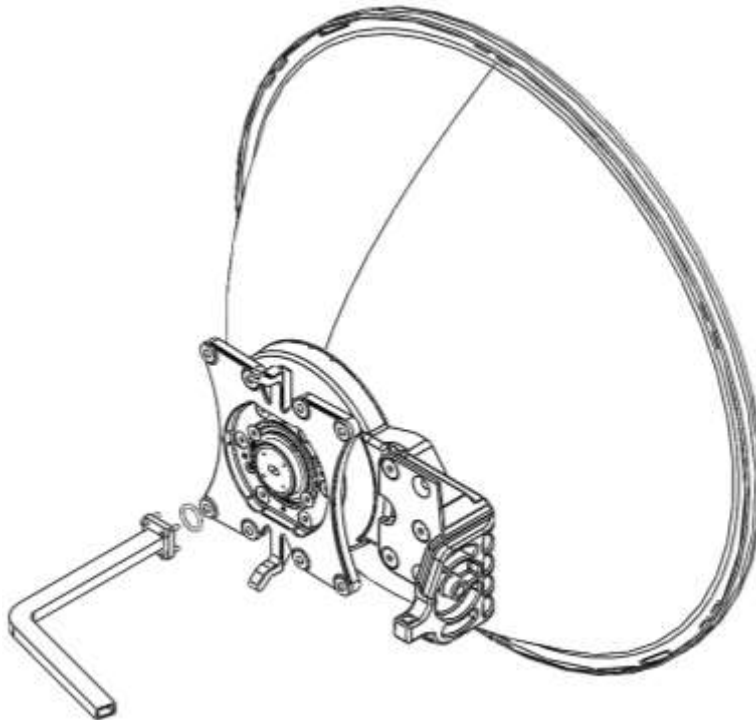

6.14 4x4 LoS MIMO Direct Mount

- Notes:**
- 1) This procedure can also be used for MultiCore 2+0 SP HW ready for 2 x MultiCore 2+0 SP configurations.
 - 2) This procedure can also be used for 2+2 SD configurations.

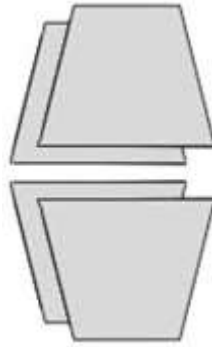

List of Items

Item	Description	Quantity	Remarks
1	IP-20C RADIO	2	
2	IP-20C OMT KIT	2	
3	MIMO DATA CABLE	1	
4	SOURCE SHARING CABLE	1	
5	CAT5E MIMO SIGNALING CABLE	1	
6	CIRC./CIRC. ADAPTOR	1	Per Antenna Vendor

Required Tools

- Metric offset hexagon key set
- Metric wrench key set

Procedure

- 1 For instructions on installation of the IP 20C OMT and radios, see *MultiCore 2+0 Dual Polarization Direct Mount* on page 81.

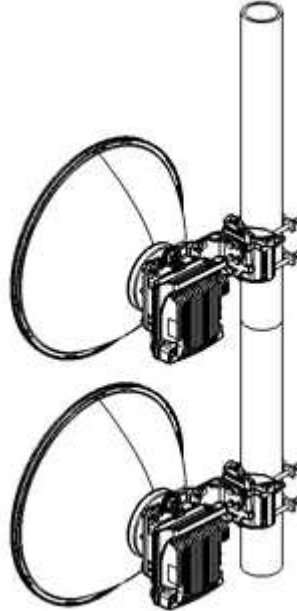

- 2 Connect the source sharing cable between both EXT REF IP-20C radio connectors. The maximum torque for connecting this cable to the radio is 5Lb.in (0.5N.m).

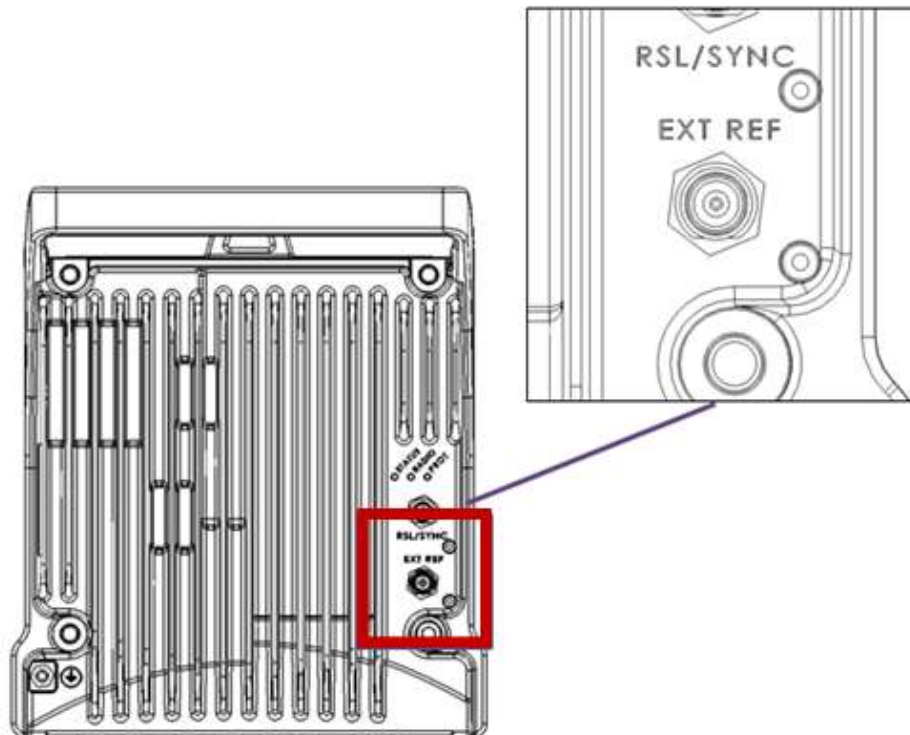

- 3 Connect the MIMO data sharing cable between both ETH3/EXT IP-20C radio connectors.

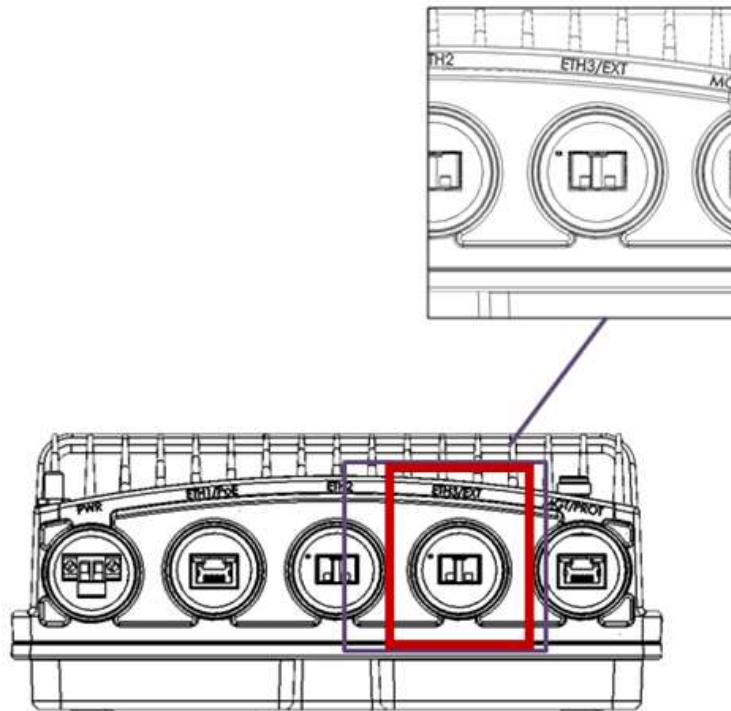

- 4 Connect the MIMO signaling cable between the management ports of both units. For additional instructions on preparing and connecting this cable, refer to *Preparing a MIMO/Protection Signaling Cable* on page 62.

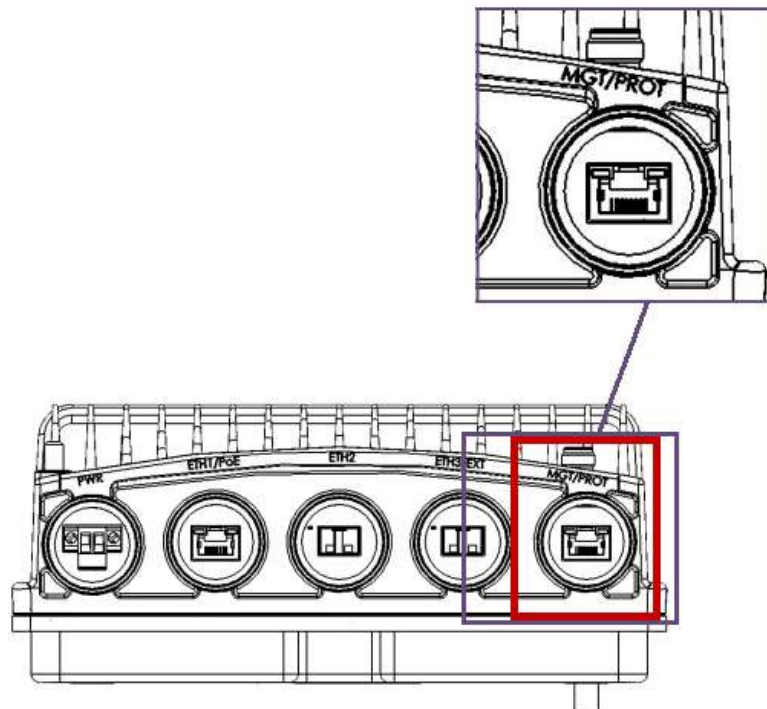

6.15 4+0 Dual Polarization, 2+2HSB Single/Dual Polarization Direct Mount

List of Items

Item	Description	Quantity	Remarks
1	IP-20C Dual Coupler/Splitter/Circulator	1	
2	IP-20C OMT/Splitter Kit	1	
3	IP-20C Radios	2	

Required Tools

- Metric offset hexagon key set
- Metric wrench key set

Procedure

- 1 Once the OMT/Splitter is mounted to the antenna, connect the IP-20C Dual Coupler/Splitter kit to the OMT kit using four M8 screws and washers, and tighten the screws.

Important: Verify that the O-ring is properly mounted between the OMT/Splitter ports and the Dual Coupler/Splitter.

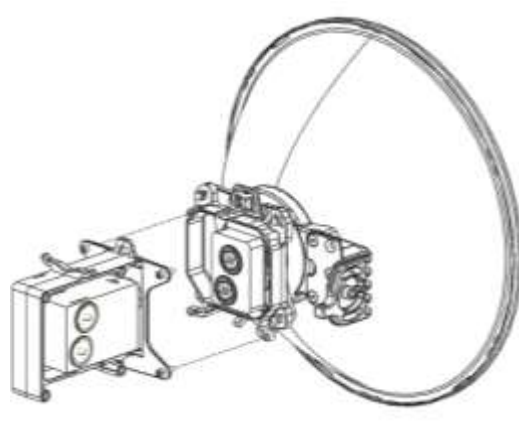

- 2 Connect the IP-20C DC radios using the four M8 captive screws and washers supplied, and tighten the screws.

Important: Verify that the O-rings are properly mounted between the Dual Coupler/Splitter ports and the radio.

6.15.1 4+0 with Dual Circulator (6-11GHz) Direct Mount

The following example illustrates a typical configuration, assuming that:

- The regulation specifies a channelization of 8 consecutive 28/38MHz channels (1-8 ch).
- The actual channels in use are channels 1,5.

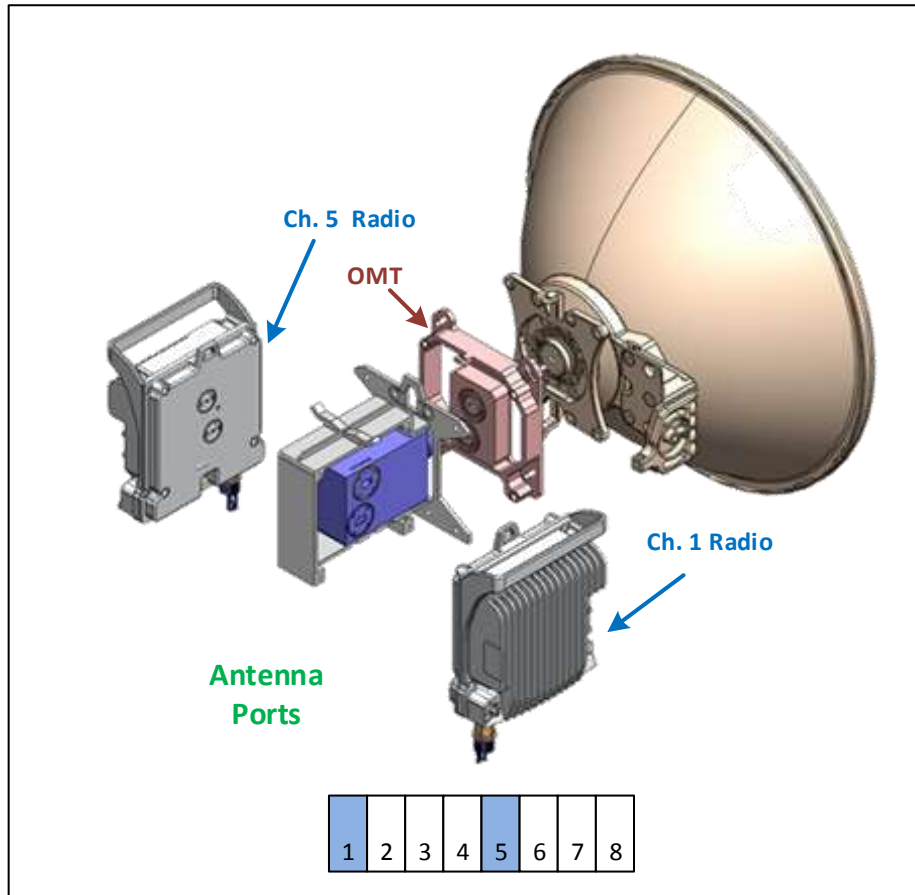

Figure 29: 4+0 with Dual Circulator (6-11GHz) Direct Mount

6.16 4+0 Dual Polarization, 2+2HSB Dual Polarization Remote Mount

List of Items

Item	Description	Quantity	Remarks
1	IP-20C OMT Kit	1	
2	Flexible Waveguide Kit	2	
3	IP-20C Dual Coupler/Splitter	1	

Required Tools

- Metric offset hexagon key set
- Metric wrench key set

Common Installation

- 1 Connect the OMT kit to the antenna and secure it with four screws.

Important: Verify that the O-ring is properly mounted between the antenna transition and the OMT.

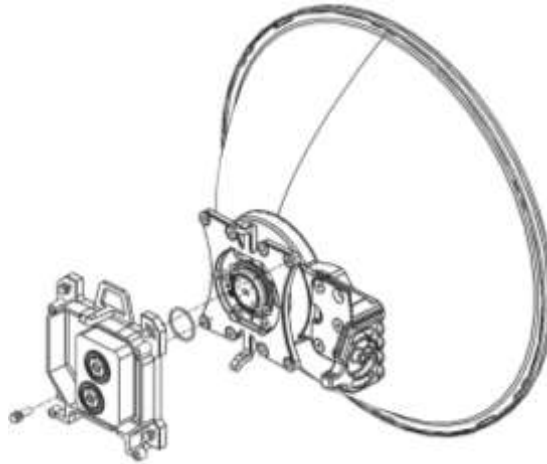

6.16.1 6-13GHz

- 1 Mount and tighten the IP-20-C Remote Mount Adaptor plate (supplied in IP-20C Adaptor Remote Mount kit) to the IP-20C Pole Mount using the four flat screws supplied with the IP-20C Adaptor Remote Mount kit.

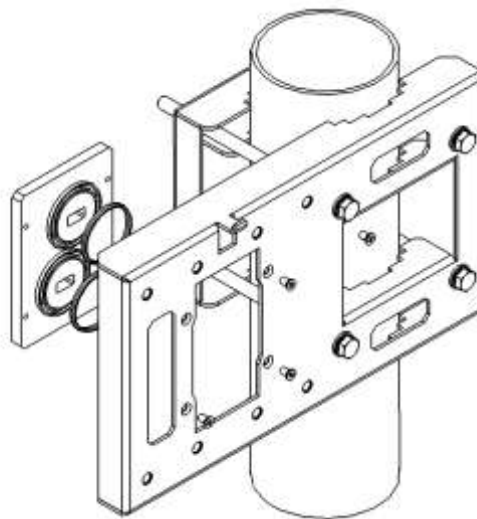

- 2 Mount and tighten the IP-20C Dual Coupler to the IP-20C Pole Mount using the four screws and washers that are supplied with the IP-20C Dual Coupler kit. Pay attention that the O-rings are mounted on the IP-20C Remote Mount Adaptor.

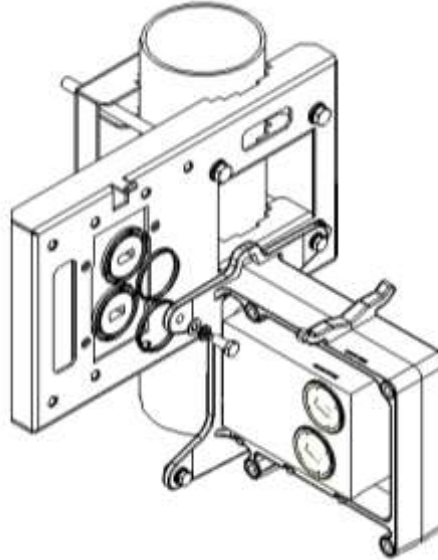

- 3 Mount and tighten the IP-20C radios on each side of the IP-20C Dual Coupler using the screws assembled on IP-20C radio. Make sure that the O-rings are correctly assembled on the radio port of the IP-20C dual coupler.

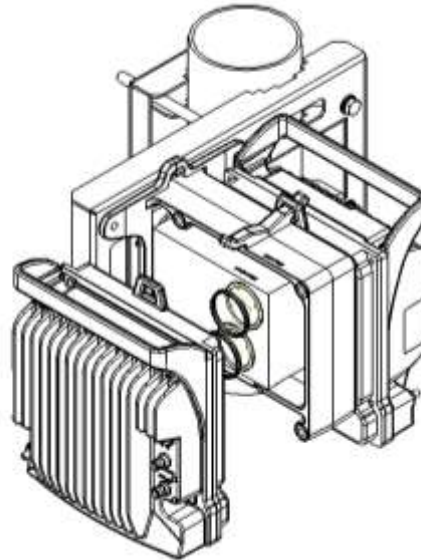

- 4 Connect both Flexible Waveguides and Sealing Gaskets supplied with each Flexible Waveguide Kit to the IP-20C Dual Coupler antenna ports. Tighten the screws and washers supplied with the Flexible Waveguide Kit.

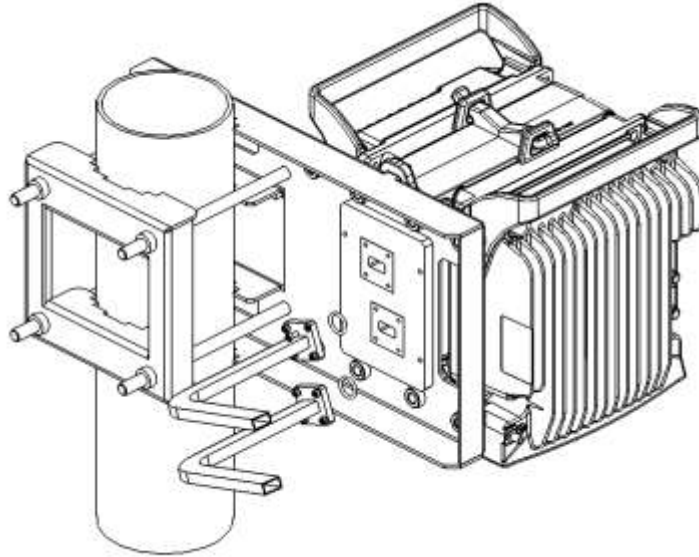

6.16.2 15-42GHz

- 1 Mount and tighten the IP-20C Dual Coupler to the IP-20C DC Pole Mount using the four screws and washers supplied with the IP-20C Dual Coupler kit.

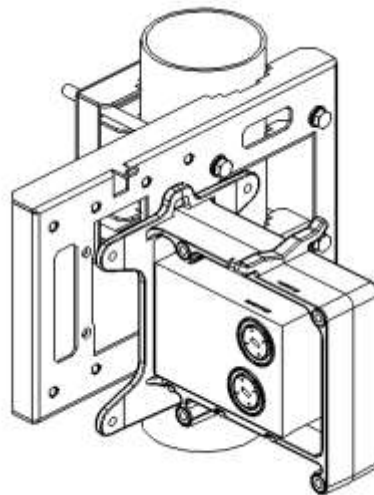

- 2 Mount and tighten the IP-20C radios on each side of the IP-20C Dual Coupler using the screws assembled on the IP-20C unit. Make sure that the O-rings are correctly assembled on the radio port of the IP-20C Dual Coupler.

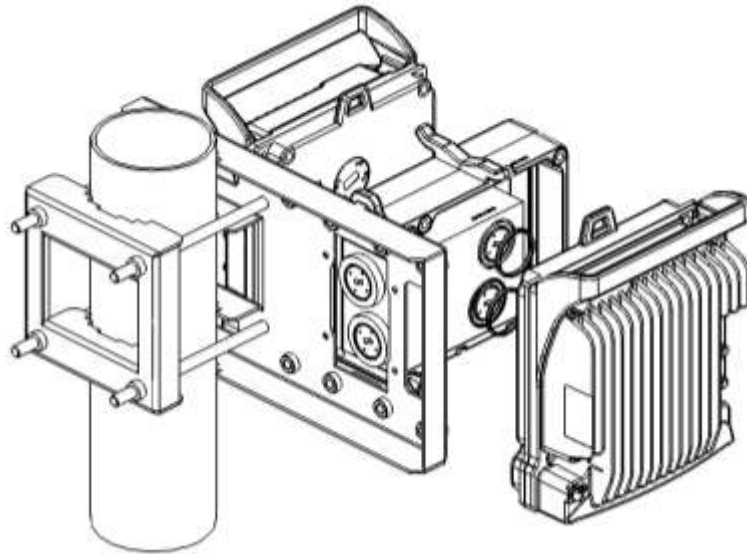

- 3 Mount the O-ring and the Flexible Waveguides to the IP-20C Dual Coupler ports using the four screws supplied with the Flexible Waveguide kits.

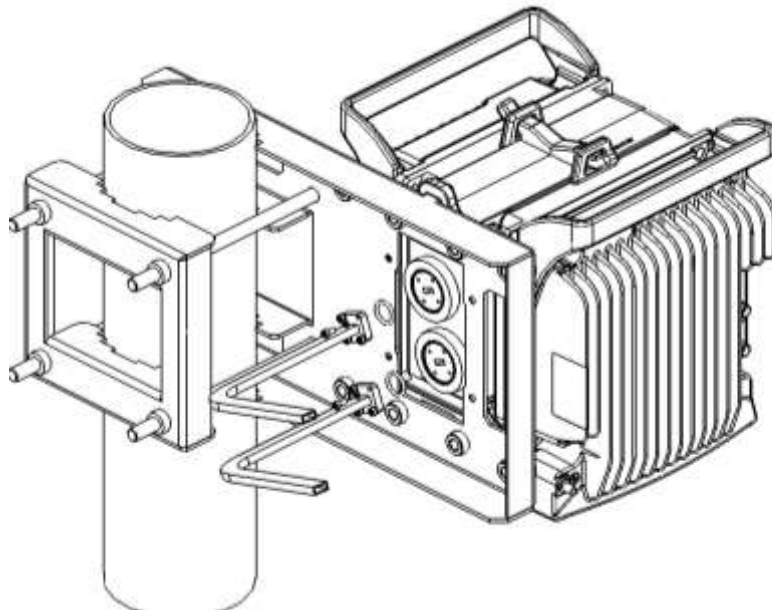

- 4 Mount and tighten the O-ring and the Flexible Waveguides to the IP-20C OMT ports using the four screws supplied with the Flexible Waveguide kits.

Important: Verify that the O-rings are correctly mounted between the OMT ports and each Flexible Waveguide.

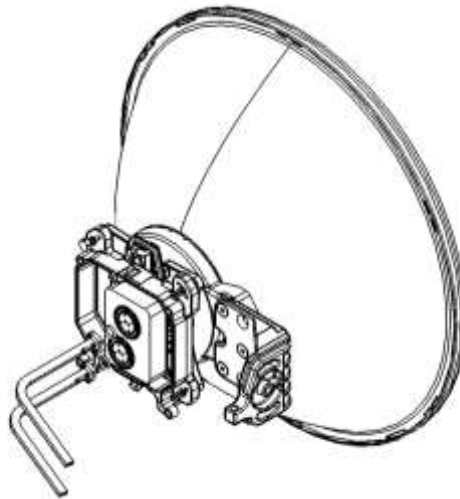

6.16.3 4+0 with Dual Circulator (6-11GHz) Remote Mount

The following example illustrates a typical configuration, assuming that:

- The regulation specifies a channelization of 8 consecutive 28/38MHz channels (1-8 ch).
- The actual channels in use are channels 1,5.

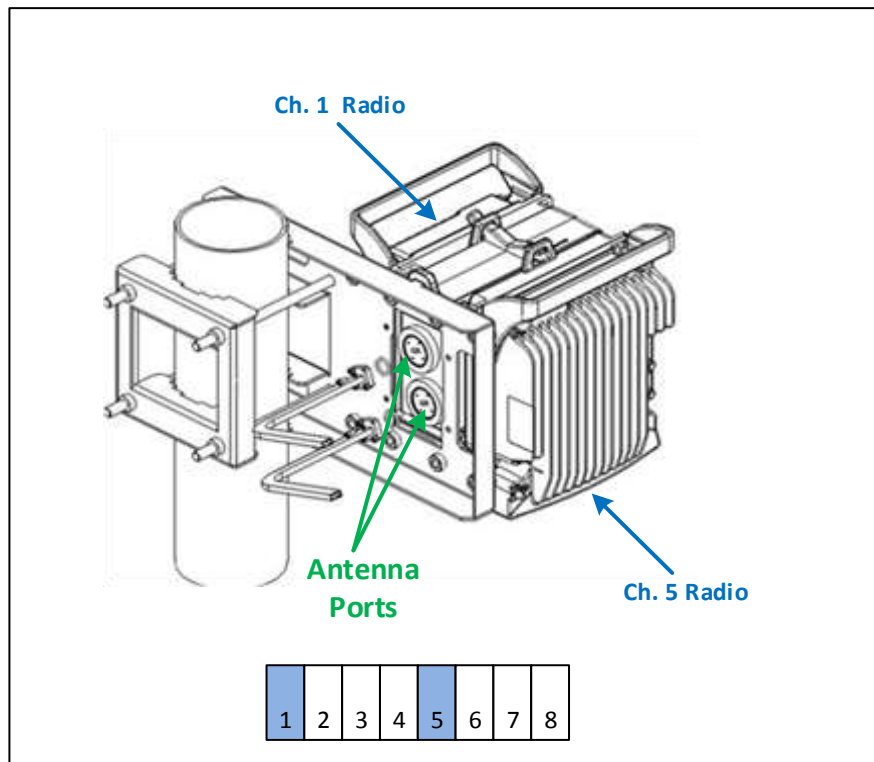

6.17 2+2HSB Single Polarization Remote Mount

Note: This procedure can also be used for 1+1HSB SP HW ready for 2+2HSB SP configurations.

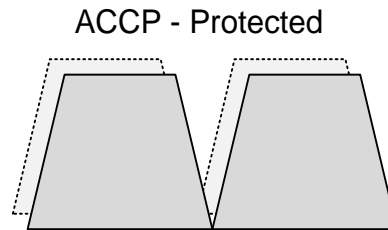

List of Items

Item	Description	Quantity	Remarks
1	IP-20C RADIO	2	
2	IP-20C SPLITTER KIT	1	
3	IP-20C DUAL COUPLER KIT	1	
4	FLEXIBLE WG KIT	2	
5	RFU-C POLE MOUNT KIT	2	

Required Tools

- Metric offset hexagon key set
- Metric wrench key set
- Phillips #1, #2 screwdriver

6.17.1 6-13GHz

- 1 Mount and tighten the RFU-C Remote Mount Adaptor plate (supplied in the RFU-C Adaptor Remote Mount kit) to the RFU-C Pole Mount using the four flat screws supplied with the RFU-C Adaptor Remote Mount kit.

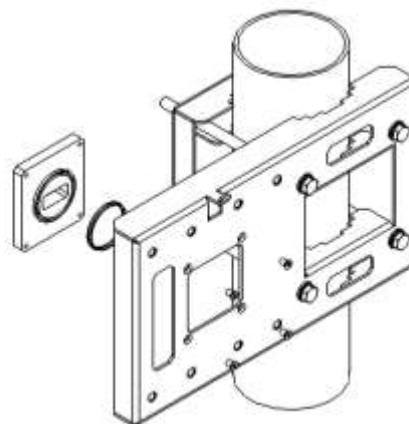

- 2 Mount and tighten the IP-20C Splitter to the RFU-C Pole Mount using the four captive screws and washers that are assembled to the IP-20C Splitter kit.

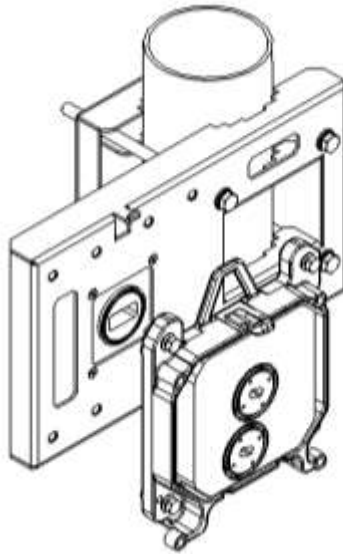

- 3 Mount and tighten the IP-20C Dual Coupler to the IP-20C Splitter using the four captive screws and washers that are supplied with the IP-20C Dual Coupler kit. Make sure that the O-rings are mounted on the IP-20C Splitter.

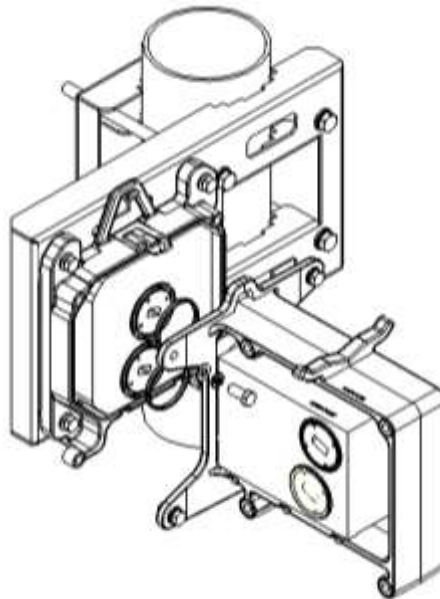

- 4 Mount and tighten the IP-20C unit to the IP-20C Dual Coupler using the four screws and washers that are assembled to the IP-20C unit. Make sure that the O-rings are mounted on the IP-20C Dual Coupler.

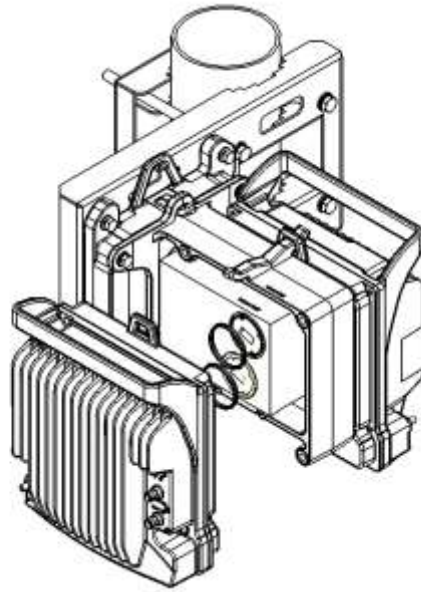

- 5 Connect the Flexible Waveguide and Sealing Gasket supplied with the Flexible Waveguide kit to the RFU-C Adaptor plate. Tighten the four screws supplied with the Flexible Waveguide kit.

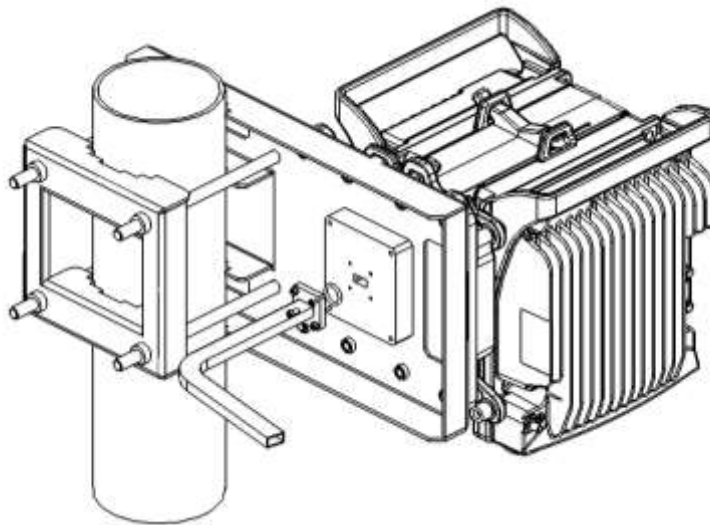

6.18 1+1 HSB-SD

List of Items

Item	Description	Quantity	Remarks
1	Flexible Waveguide Kit	2	
2	IP-20C Dual Coupler/Splitter	1	

Required Tools

- Metric offset hexagon key set
- Metric wrench key set

6.18.1 6-13GHz

- 1 Mount and tighten the IP-20-C Remote Mount Adaptor plate (supplied in IP-20C Adaptor Remote Mount kit) to the IP-20C Pole Mount using the four flat screws supplied with the IP-20C Adaptor Remote Mount kit.

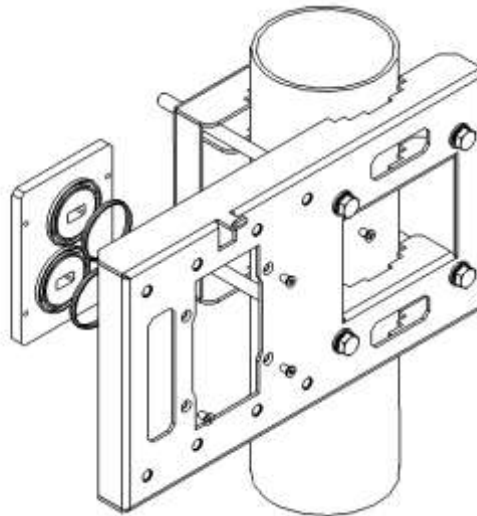

- 2 Mount and tighten the IP-20C Dual Coupler to the IP-20C Pole Mount using the four screws and washers that are supplied with the IP-20C Dual Coupler kit. Pay attention that the O-rings are mounted on the IP-20C Remote Mount Adaptor.

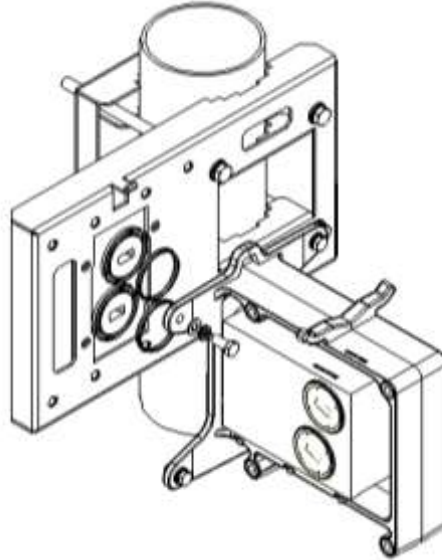

- 3 Mount and tighten the IP-20C radios on each side of the IP-20C Dual Coupler using the screws assembled on IP-20C radio. Make sure that the O-rings are correctly assembled on the radio port of the IP-20C dual coupler.

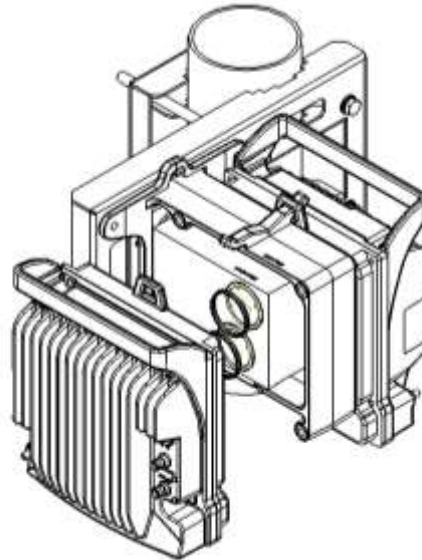

- 4 Connect both Flexible Waveguides and Sealing Gaskets supplied with each Flexible Waveguide Kit to the IP-20C Dual Coupler antenna ports. Tighten the screws and washers supplied with the Flexible Waveguide Kit.

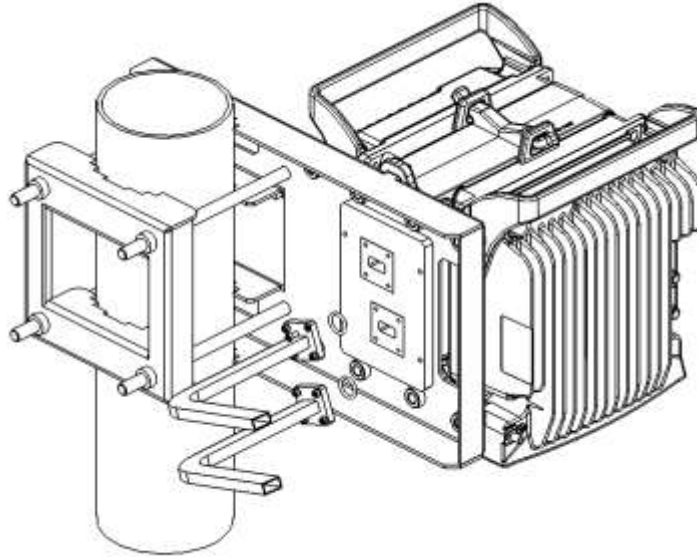

6.18.2 15-42GHz

- 1 Mount and tighten the IP-20C Dual Coupler to the IP-20C DC Pole Mount using the four screws and washers supplied with the IP-20C Dual Coupler kit.

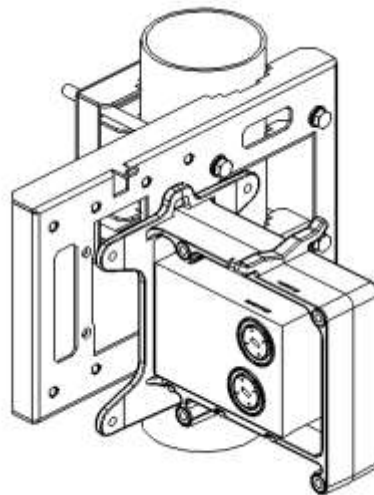

- 2 Mount and tighten the IP-20C radios on each side of the IP-20C Dual Coupler using the screws assembled on the IP-20C unit. Make sure that the O-rings are correctly assembled on the radio port of the IP-20C Dual Coupler.

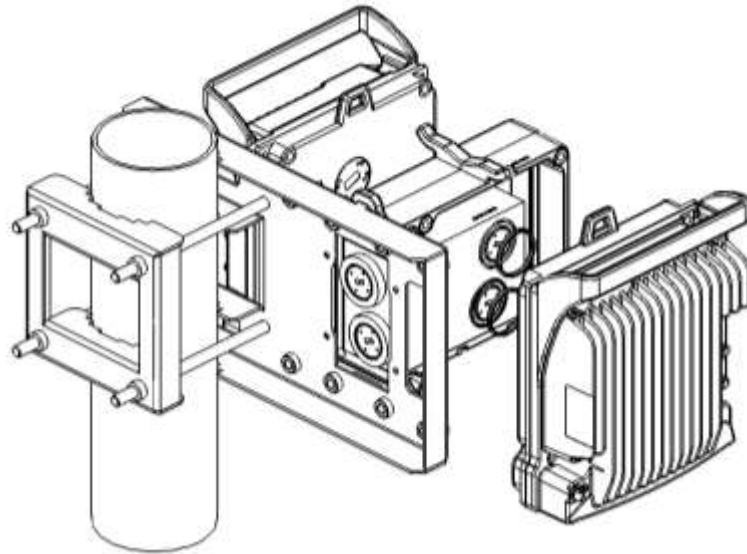

- 3 Mount the O-ring and the Flexible Waveguides to the IP-20C Dual Coupler ports using the four screws supplied with the Flexible Waveguide kits.

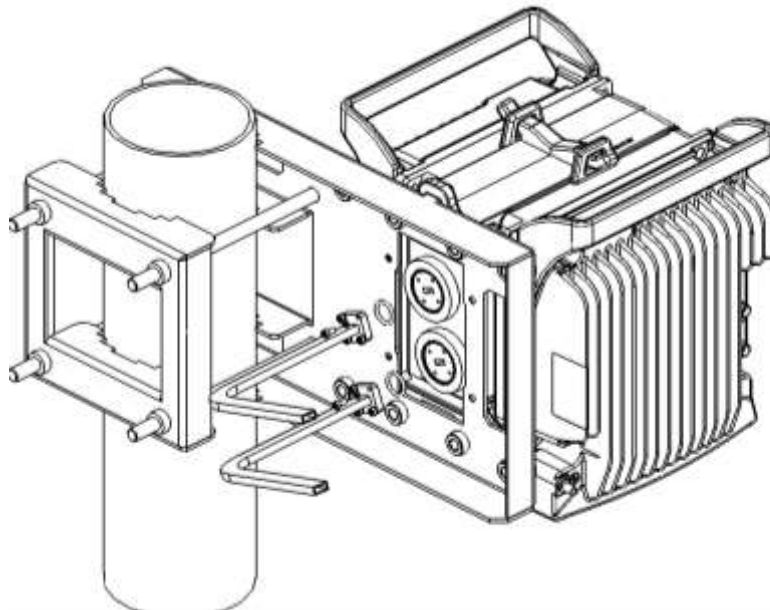

- 4 Mount and tighten the O-ring and the Flexible Waveguides to the antenna ports on the primary and diversity antennas using the four screws supplied with the Flexible Waveguide kits.

Important: Verify that the O-rings are correctly mounted between the OMT ports and each Flexible Waveguide.

6.19 Dual Circulator Multi-Carrier Kit Installation

List of Items

Item	Description	Quantity	Remarks
1	IP-20C RADIO	4	
2	IP-20C_DUAL_CIRC_kit_xxG	2	
3	IP-20C_MC_DUAL_CIRC_kit_xxG	1	

Required Tools

- Metric offset hexagon key set
- Metric wrench key set

Procedure

- 1 Mount and tighten the pillar adapter brackets to pole (supplied in IP-20C Adaptor Remote Mount kit). Tighten the four M10 Hex screws and washers supplied within the kit.

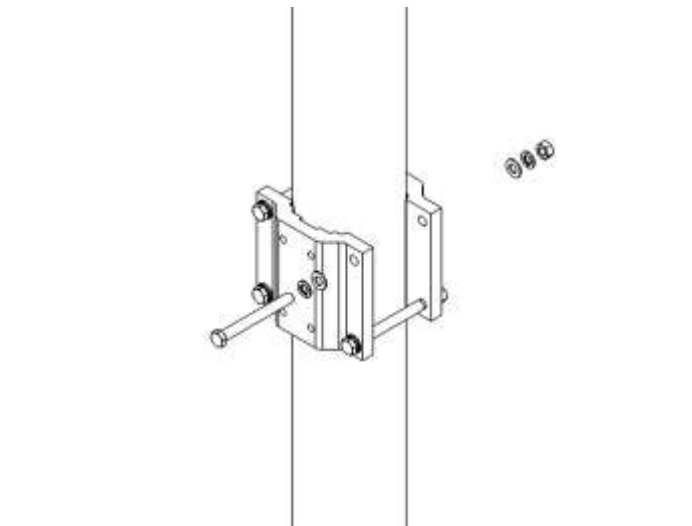

6.19.1 6-8 GHz

- 1 Mount and tighten the IP-20C MC Dual Cir to the IP-20C pillar adapter bracket using the four M8 Hex screws and washers supplied within the kit.

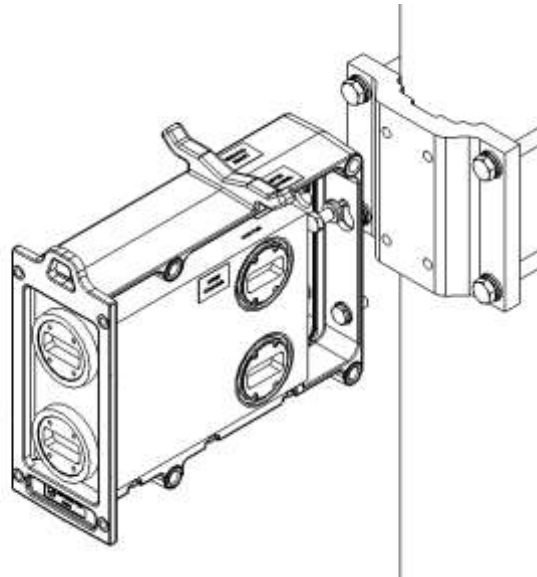

6.19.2 11 GHz only

- 1 Mount and tighten the IP-20C MC extender to the IP-20C pillar adapter bracket using the four M8 Hex screws and washers supplied within the kit.

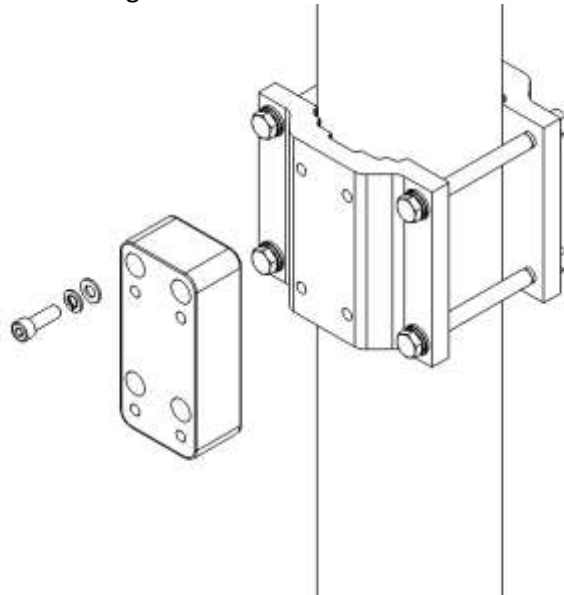

- 2 Mount and tighten the IP-20C MC Dual Cir to the IP-20C MC Extender using the four M8 Hex screws and washers supplied within the kit.

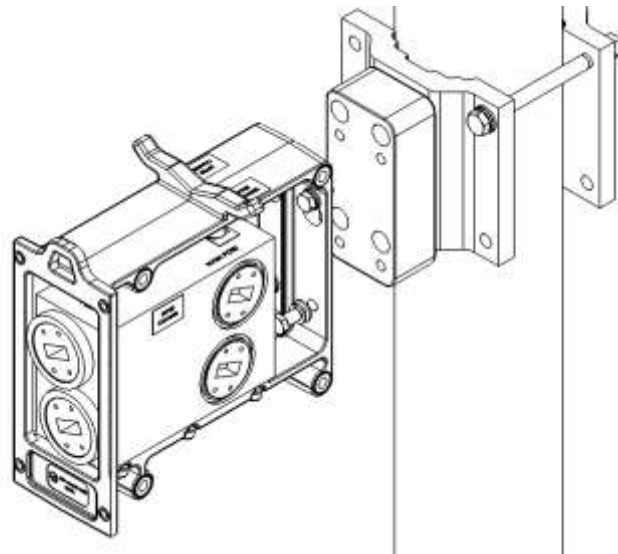

6.19.3 6-11GHz

- 1 Mount and tighten the IP-20C Dual Circ to each side of the IP-20 MC Dual Circ using the four M8 Hex screws and washers supplied in the IP-20 Dual Circ kit. Pay attention that the O-rings on the IP-20C MC Dual Circ are well in place during the mounting.

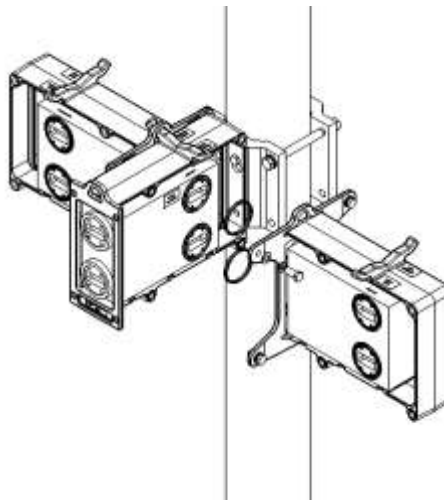

- 2 Mount and tighten the IP-20C radios to each IP-20C Dual Circ radio port using the four screws assembled on the IP-20C radio. Pay attention that the O-rings on the IP-20C Dual Circ are well in place during the mounting.

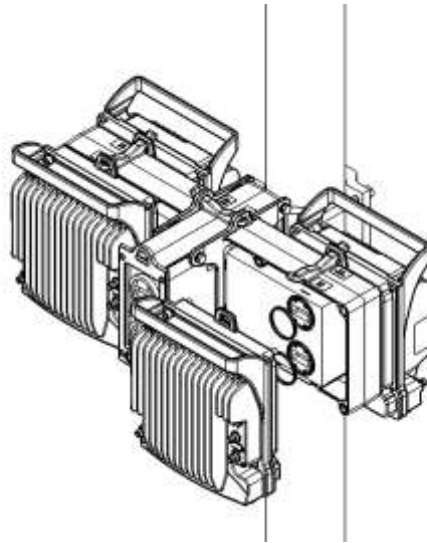

- 3 Mount and tighten the IP-20C MC Remote mount adapter to the IP-20C MC Dual Circ antenna ports using the four screws assembled on the IP-20C radio. Pay attention that the O-rings on the IP-20C MC Remote mount adapter are well in place during the mounting.

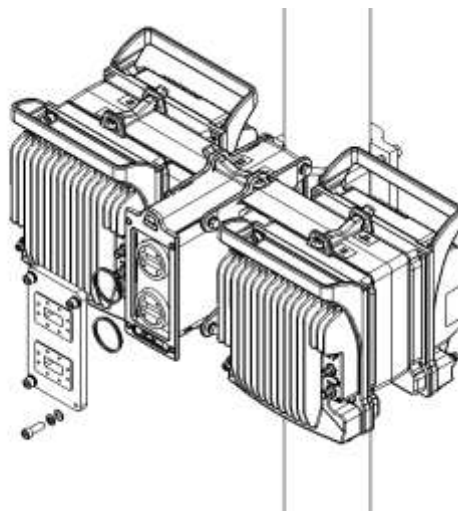

- 4 Mount and tighten the O-ring and the Flexible WG to the IP-20C MC Remote mount adapter ports using the four screws supplied with the Flexible WG kit.
- 5 Mount and tighten the O-ring and flexible WG to both antenna ports using the four screws supplied with the flexible WG kit.

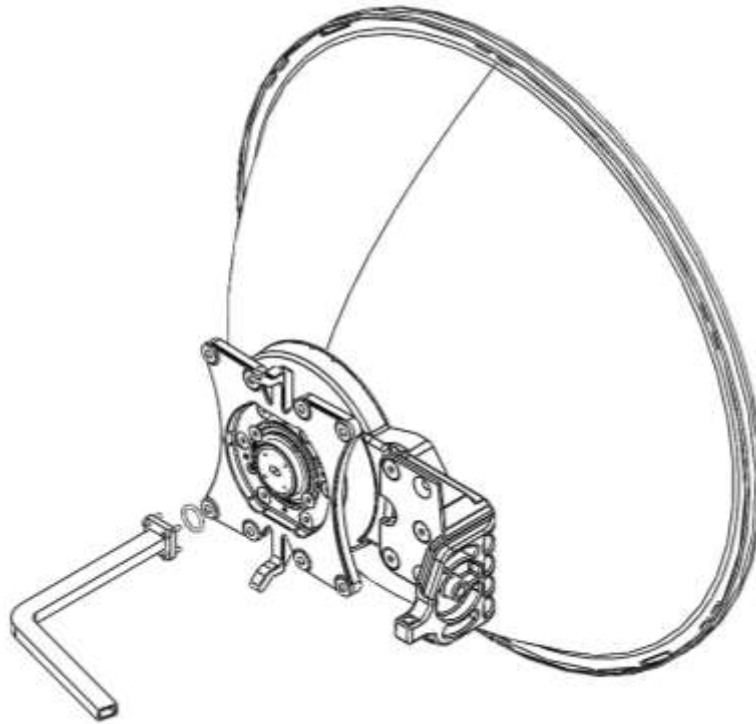

The following example illustrates a typical configuration, assuming:

- The regulation specifies a channelization of 8 consecutive 28/30 MHz channels (1-8ch).
- The actual channels in use are channels 1, 5.

4+0 Configuration

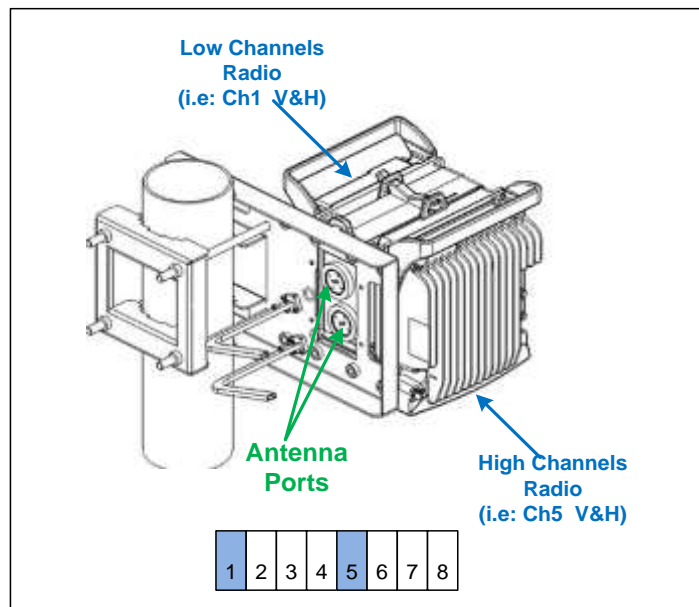

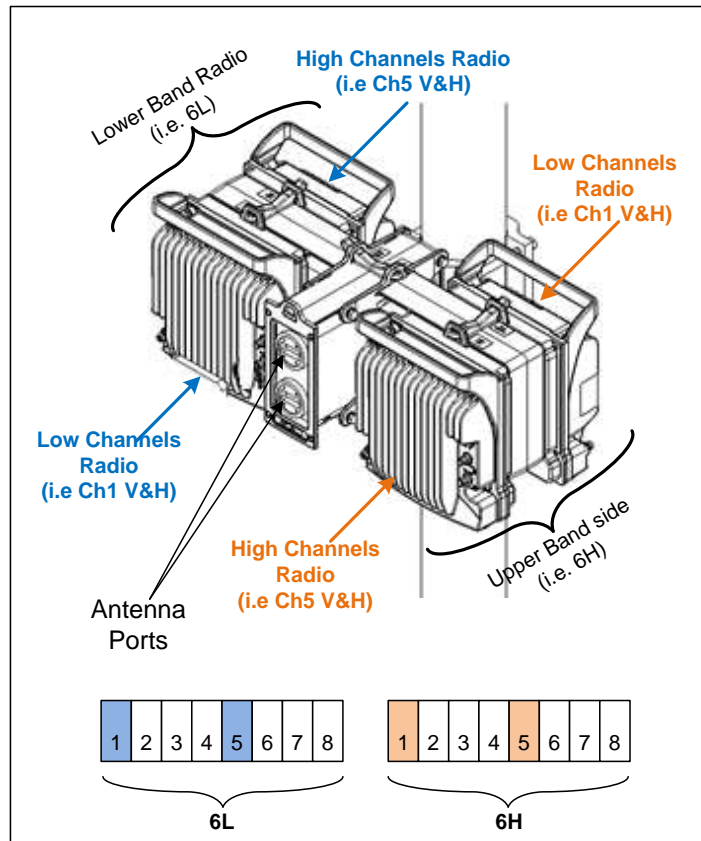

6.20 AFR 1+0 Hub Site

In an AFR 1+0 configuration, a Multicore FibeAir IP-20C unit is deployed at the hub site and two FibeAir IP-20C or IP-20S units are deployed in two tail sites.

The hub site utilizes a single FibeAir IP-20C unit with two radio carriers. Each carrier is in a link, via its own directional antenna, with a tail site that consists of a FibeAir IP-20C or IP-20S unit.

Note: The links should be located so as to ensure that the two radio paths do not cross.

The tail site unit is installed as a simple 1+0 configuration.

The hub site unit is installed as a remote mount configuration in which two flexible waveguides are used to connect the two Remote Mount Adaptor ports to an antenna. This chapter describes a hub site installation.

For standard interface antennas (six feet and larger), no OMT and no Circ./Circ. Adaptor are used, and the flexible waveguides are connected directly to the antenna flanges. For instructions how to connect the waveguides to the antenna flanges, refer to the antenna vendor's documentation.

List of Items

Item	Description	Quantity	Remarks
1	IP-20C RADIO	1	
3	FLEXIBLE WG KIT	2	
4	IP-20C DC POLE MOUNT KIT	1	
5	IP-20C DC REMOTE MOUNT ADAPTOR KIT	1	From 6-13GHz
6	Circ./Circ. Adaptor	1	Per Antenna Vendor. Not used for standard interface antennas (six feet and larger).

Required Tools

- Metric offset hexagon key set
- Metric wrench key set
- Phillips #1, #2 screwdriver

6.20.1 Common Installation

- 1 Prior to the installation, follow the antenna manufacturer's instructions to use the circular adaptor. (Remove the existing rectangular transition, swap the O-ring, and install the circular transition instead.)



- 2 Mount and tighten the Flexible WG to the antenna port using the four screws supplied with the Flexible WG kit.

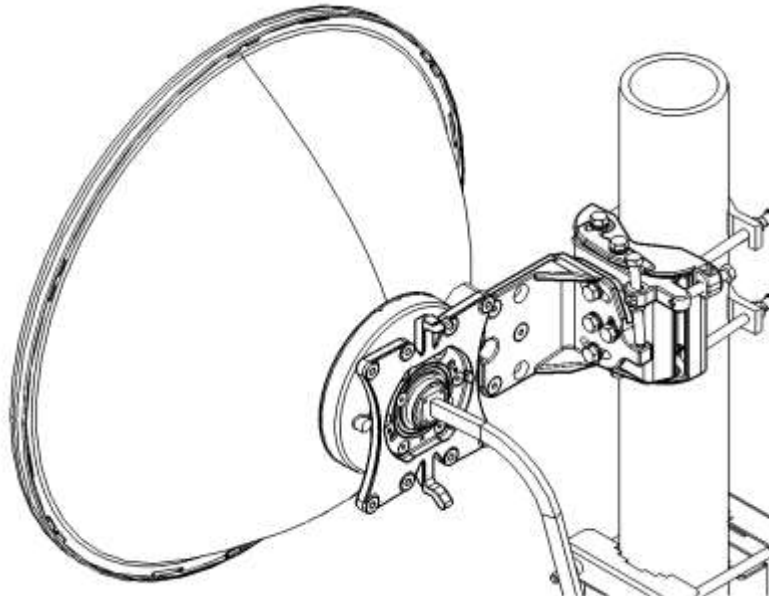

6.20.2 6-13 GHz

- 1 Mount and tighten the IP-20C Remote Mount Adaptor plate (supplied in IP-20C Adaptor Remote Mount kit) to the IP-20C Pole Mount using the four flat screws supplied with the IP-20C Adaptor Remote Mount kit.

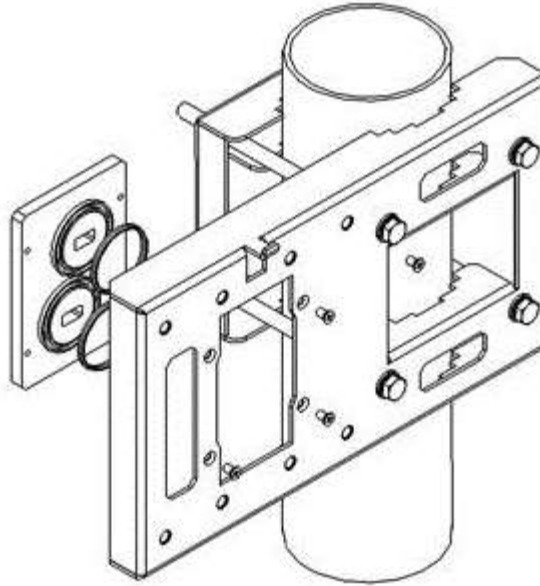

- 2 Mount and tighten the IP-20C to the IP-20C Pole Mount using the four captive screws and washers that are supplied with the IP-20C. Pay attention that the O-rings are mounted on the IP-20C Remote Mount Adaptor.

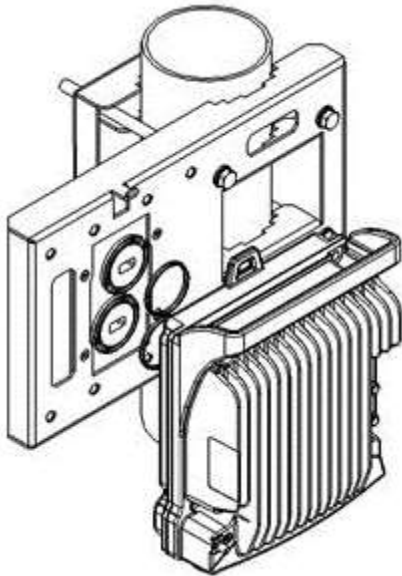

- 3 Mount and tighten both Flexible WGs with their O-ring to the IP-20C Remote Mount Adaptor ports using the four screws supplied with each Flexible WG kit.

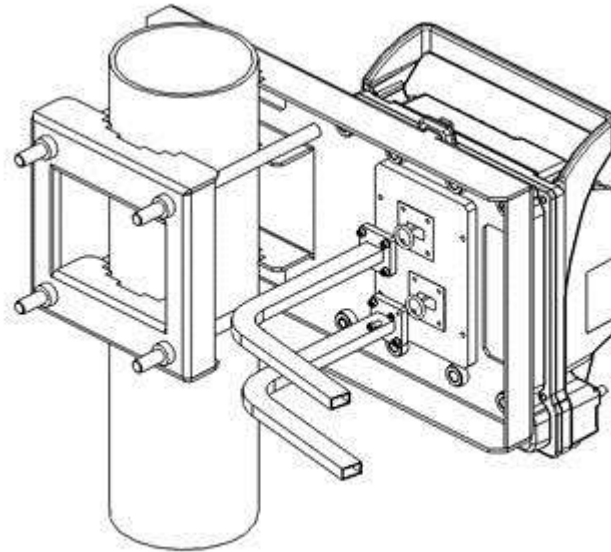

6.20.3 15-42 GHz

- 1 Mount and tighten the IP-20C to the IP-20C DC Pole Mount using the four screws assembled on the IP-20C.

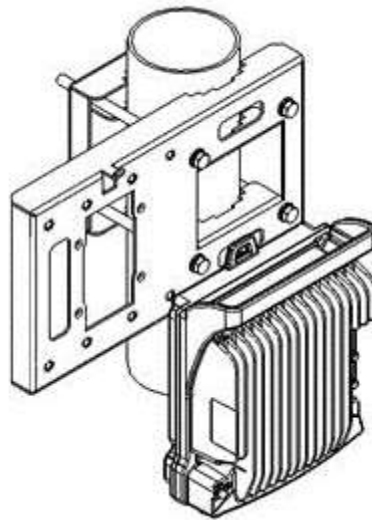

- 2 Mount and tighten the O-ring and the Flexible WG to IP-20C radio ports using the four screws supplied with the Flexible WG kit.

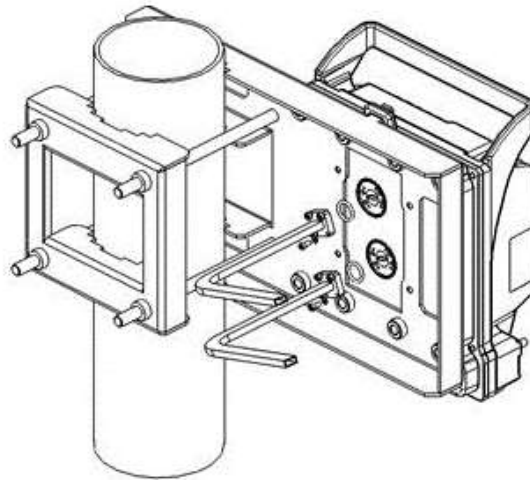

The following figure shows the complete installation.

Note: This figure shows an installation with horizontal polarization. Vertical polarization can also be used. The same polarization must be used for both links.

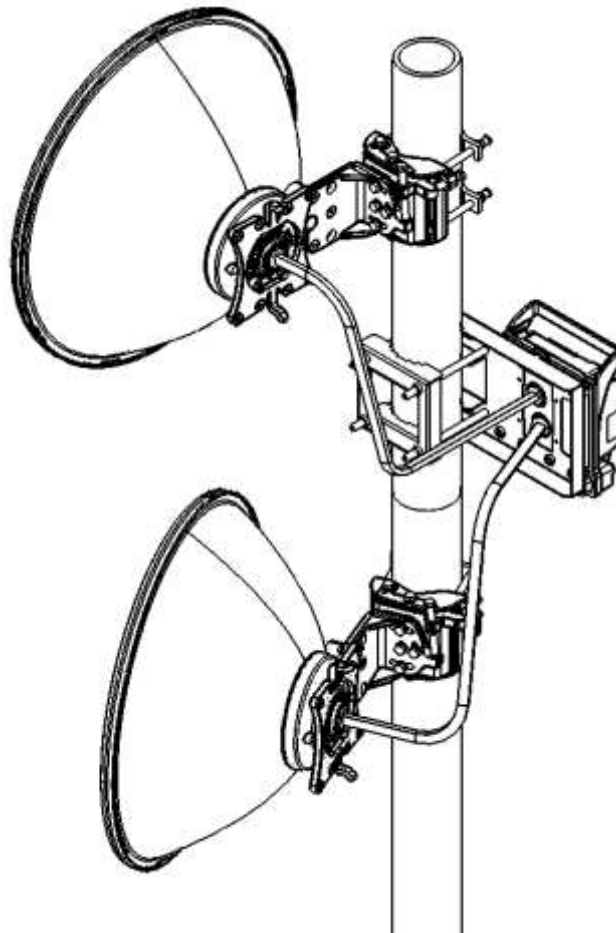

7. Installing IP-20C on Third-Party Antenna Adaptors

Since the IP-20C uses the same antennas as RFU-C, it can utilize the 3rd party mediation devices much in the same way they are used with RFU-C installations.

Special attention must be taken in assembling these configurations, as the 3rd party adaptors can be used only for single polarization configurations. Dual polarization configurations can be accommodated neither with RFU-C nor with IP-20 C.

In general, once the correct 3rd party adaptor has been selected and installed on the antenna, the interface now is identical to a generic single pol. RFU-C interface. From this moment forth it is ready for any subsequent IP-20C configuration.

The following tables describe available adaptors:

Table 32: 3rd-Party Adaptors, 6 GHz – 15 GHz

Other Vendors Antennas	6GHz	7-8GHz	10-11GHz	13GHz	15GHz
RFU-C - NEC Adaptor kit (PASOLINK NEO)				ADPT_RFU-C13_15-NC_ANT	
RFU-C - ERICSSON Adaptor kit (RAU1)				ADPT_RFU-C13-ERCS_RAU1_ANT	ADPT_RFU-C15-ERCS_RAU1_ANT
RFU-C - ERICSSON Adaptor kit (RAU2)				ADPT_RFU-C13-ERCS_ANT	ADPT_RFU-C15-ERCS_ANT
RFU-C - SRAL (SIEMENS) Adaptor kit		MK-4161-0		MK-4162-0	MK-4163-0
RFU-C-NSN (Flexihopper) ADAPTOR KIT		ADPT_RFU-C7_8-N_ANT		ADPT_RFU-C13-N_ANT	ADPT_RFU-C15-N_ANT
RFU-C - ALU Adapter Kit				ADPT_RFU-C13-ALU_Melody	
RFU-C – Huawei Adapter Kit		ADPT_RFU-C7_8-HUAW_ANT	ADPT_RFU-C10_11-HUAW_ANT		
IP-20C/S and RFU-C - Dragonwave Adapter Kit			ADPT-CIRC-RFU-C_11-DW	ADPT-CIRC-RFU-C_13-DW	
Kit for converting a ValuLine 3 antenna for integration with RFU-C (ValuLine 3 antennas only). For important information when these kits can be used, see <i>Special Note on Converting ValuLine 3 Antennas</i> on page 164.	VINTA-6W-CR4	VINTA-7W-CR4	VINTA-11W-CR4	VINTA-13-CR4	VINTA-15-CR4

Table 33: 3rd-Party Adaptors, 18 GHz – 38 GHz

Other Vendors Antennas	18GHz	23GHz	26GHz	28-31GHz	32GHz	38GHz
RFU-C - NEC Adaptor kit (PASOLINK NEO)	ADPT_RFU-C18_26-NEC_ANT					
RFU-C - ERICSSON Adaptor kit (RAU1)	ADPT_RFU-C18-ERCS_RAU1_ANT	ADPT_RFU-C23-26-ERCS_RAU1_ANT	ADPT_RFU-C28-38-ERCS_RAU1_ANT			
RFU-C - ERICSSON Adaptor kit (RAU2)	ADPT_RFU-C18-ERCS_ANT	ADPT_RFU-C23-ERCS_ANT	ADPT_RFU-C28_38-ERCS_ANT			
RFU-C - SRAL (SIEMENS) Adaptor kit	ADPT_RFU-C18_26-SRAL_ANT			ADPT_RFU-C28_38-SRAL_ANT		
RFU-C-NSN (Flexihopper) ADAPTOR KIT	ADPT_RFU-C18_26-N_ANT					ADPT_RFU-C38-N_ANT
RFU-C - ALU Adapter Kit	ADPT_RFU-C18-ALU_Melody					
IP-20C/S and RFU-C - Dragonwave Adapter Kit	ADPT-CIRC-RFU-C_18-DW	ADPT-CIRC-RFU-C_23-DW				
RFU-C – SIAE ADAPTOR KIT – Single Polarization	ADPT_RFU-C18_SIAE_ANT_SP					
RFU-C – SIAE ADAPTOR KIT – Dual Polarization	ADPT_RFU-C18_SIAE_ANT_DP					
Kit for converting a ValuLine 3 antenna for integration with RFU-C (ValuLine 3 antennas only). For important information on when these kits can be used, see <i>Special Note on Converting ValuLine 3 Antennas</i> on page 164.	VINTA-18-CR4	VINTA-23-CR4	VINTA-26-CR4	VINTA-28-CR4	VINTA-32-CR4	VINTA-38-CR4

Note: For instructions how to install these third-party adaptors, refer to the FibeAir RFU-C Installation Guide, DOC-00017708.

7.1 Special Note on Converting ValuLine 3 Antennas

Part numbers for ValuLine 3 antenna conversion kits are valid for most ValuLine 3 antennas, integrated or non-integrated. These conversion kits can also be used to convert CommScope ValuLine 3 antennas with the old Nera Evolution interface to RFU-C. The kits support the majority of CommScope's ValuLine 3 antennas, 1-6ft. However, since there are some unique cases in which CommScope provided special antennas which are not supported by these adaptors, it is recommended that you supply your Ceragon representative with a picture of the current antenna (back plain side), in order to confirm the antenna's compatibility prior to implementing this solution.

You can also check the following to determine whether the antenna is compatible with the conversion kit:

- Verify that the antenna is, in fact, a ValuLine 3 antenna.
- Verify that the back plate of the antenna has in its holding plate the six mounting holes shown in red in the figure below.

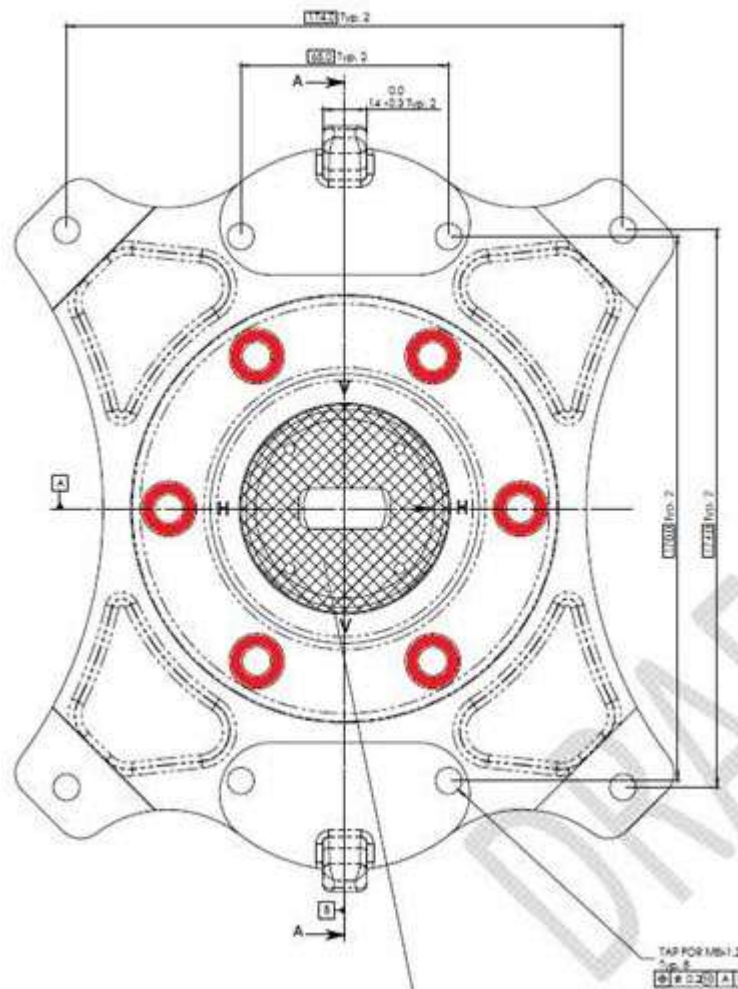

8. **Appendix A: Acceptance & Commissioning Procedures**

This chapter provides Ceragon's recommended Acceptance and Commissioning Procedure for IP-20. Acceptance and commissioning should be performed after initial setup is complete.

The purpose of this procedure is to verify correct installation and operation of the installed link and the interoperability with customer end equipment.

Ceragon's Acceptance and Commissioning procedure includes the following stages:

- Site Acceptance Procedure
- Commissioning of Radio Link

The Site Acceptance Procedure is a checklist that summarizes the installation requirements of the site at which the products were installed.

The commissioning tests cover the required configuration information that should be recorded, and the tests that should be performed on the radio link.

8.1 Site Acceptance Procedure

The purpose of the following procedures is to verify that all installation requirements were noted and checked. Following this procedure will ensure proper, long-lasting, and safe operation of the product.

The checklist below summarizes the installation requirements of the site.

SITE ACCEPTANCE CHECKLIST	
1. SITE INFORMATION	
Customer:	
Radio model:	
Site name:	
Site code:	
Radio link code:	
Site address:	
2. ANTENNA MOUNTING	
Antenna mount type:	
Mount is of sufficient height to clear local obstructions	OK
Mount is safely positioned to not cause a safety hazard	OK
Mount is secure and perpendicular	OK
Mount is grounded as per site specifications	OK
All steelwork is Galvanized or Stainless Steel as appropriate	OK
3. ANTENNA	
Antenna type (model and size):	
Antenna is securely fixed to mount	OK
Antenna is grounded as per site specifications	OK
Antenna sway braces are installed correctly (where applicable)	OK
Antenna Radome is securely fitted (where applicable)	OK
Water drain plugs are fitted and removed, as appropriate	OK
Antenna sealing O-Ring is properly fitted and not damaged	OK
Antenna/Launch unit polarization is as per link requirements	OK

SITE ACCEPTANCE CHECKLIST (continued)
--

4. OUTDOOR UNIT	
Type of ODU mount:	(Direct or Remote mount)
ODU is securely mounted to the antenna or pole	OK
ODU is grounded as per installation instructions	OK
ODU's polarization is as per link requirements	OK
ODU is installed properly and has no physical damage	OK
<i>For Remote-Mount Only:</i>	
Remote mount kit is securely mounted to the pole	OK
Flexible waveguide has no physical damage and connectors are sealed	OK
All flexible waveguide bolts are secured using washers and lock-washers, as appropriate	OK
Flexible waveguide is secured to the pole	OK
6. CAT5/Fiber Optic CABLE	
Overall cable length:	
Cable type:	
CAT5 connectors assembled properly on the cable	OK
Cable connected securely to ODU and IDU	OK
Cable connector is covered by gland and secure by cable tie at the ODU	OK
At the ODU, cable has a service/drip loop to prevent moisture from entering the connector	OK
Cable is secured using suitable restraints to fixed points at regular intervals (0.5 m recommended)	OK
Cable has no sharp bends, kinks, or crushed areas. All bends are per manufacturer specifications	OK
Grounding is as per site specifications	OK
Cable point-of-entry to building/shelter is weather-proof	OK
Cable ends are properly labeled	OK

SITE ACCEPTANCE CHECKLIST (continued)	
7. FLEXIBLE WAVEGUIDE	
Overall flexible WG length:	
Flexible WG type:	
Flexible WG is connected securely to ODU and Antenna	OK
Flexible WG connector is weather-proofed (sealed) at the ODU	OK
At the ODU, the flexible WG has a service/drip loop to prevent moisture from entering the connector	OK
Flexible WG is secured using suitable restraints to fixed points at regular intervals (0.5 m recommended)	OK
Flexible WG has no sharp bends, kinks, or crushed areas. All bends are per manufacturer specifications	OK
Flexible WG point-of-entry to building/shelter is weather-proof	OK
Flexible WG ends are properly labeled	OK
8. DC POWER SUPPLY - Two Inputs	
Measured DC voltage input to the IDU:	(-40.5 to -60 VDC)
Power-Supply maximum current:	
Power-Supply is properly grounded	OK
DC power backup type:	
IDU DC connector is secure and the DC input leads are correctly terminated (no bare wires are visible)	OK
IDU DC connector (+) and (GND) leads are shorted and GND is grounded	OK
9. RACK INSTALLATION	
Rack is mounted to the shelter floor with four screws	OK
Rack is mounted to the shelter wall with two screws	OK

SITE ACCEPTANCE CHECKLIST (continued)	
10. REMARKS/NOTES	
11. GENERAL INFORMATION	
Site accepted by:	Name:
	Title:
	Company:
	Signature:
	Date:
Site approved by:	Name:
	Title:
	Company:
	Signature:
	Date:

8.2 Site Acceptance Checklist Notes

The following notes provide important additional information about the Site Acceptance Checklist.

1 Antenna Mounting

- Mounting pole is of sufficient height to clear local obstructions, such as parapets, window cleaning gantries, and lift housings.
- Mounting Pole is of sufficient height, and is safely positioned, so as not to cause a safety hazard. No person should be able to walk in front of, or look directly into the path of the microwave radio beam. Where possible, the pole should be away from the edge of the building.
- Mounting pole is secure and perpendicular. A pole that is not perpendicular may cause problems during antenna alignment.
- Mounting pole is grounded as per site specifications. All operators and site owners have specific requirements regarding the grounding of installations. As a minimum, typical requirements are such that any metal structure must be connected to the existing lightning protection ground of the building. Where it extends beyond the 45 degree cone of protection of existing lightning conductors, additional lightning protectors should be installed.
- All steelwork is Galvanized or Stainless Steel, as appropriate to prevent corrosion.

2 Antenna

- Antenna is grounded as per site specifications. See the third point in the Antenna Mounting section above.
 - Antenna sway braces are fitted and installed correctly, where applicable. Typically, for an antenna of 1.2 m or larger, an extra sway brace is fitted to the mounting frame of the antenna. This sway brace should not be mounted to the same pole as the antenna, but should be installed directly back to the tower or an alternative point.
 - Antenna Water Drain Plugs are fitted and removed, where appropriate. Some antennas have moisture drain plugs installed at various points around the antenna. The purpose of these plugs is to allow any moisture that forms on the inside of the antenna or radome to drip out and prevent a pool within the antenna. Only the plugs at the bottom of the antenna, after installation, should be removed. All other plugs should be left in position.
- 3 ODU (Outdoor Unit)
- The ODU is grounded as per installation instructions. See the third point in the Antenna Mounting section above.
 - The ODU polarization is as per link requirements and matches the polarization of the antenna.
 - The main traffic connections are correctly terminated and crimped as per cable and connector manufacturer instructions. All fiber optic patch leads should be routed carefully and efficiently, using conduits to prevent damage to the cables.
 - All other user terminations are secure and correctly terminated.
 - All labeling is complete as per site requirements. Labeling is specific to each customer. At a site with only one installation, labeling may be unnecessary. However, at sites with multiple installations, correct and adequate labeling is essential for future maintenance operations.

Typical labeling requirements include:

Antenna labels - for link identity and bearing

ODU labels - for link identity, frequency, and polarization

Cat5/Fiber cable labels - for link identity, close to the ODU, switch, and either end of any joint

Switch labels - for link identity

8.3 Radio Link Commissioning Procedure

8.3.1 Scope

This section describes the recommended commissioning tests for IP-20 radio link in a 1+0 configuration.

The purpose of the commissioning tests is to verify correct and proper operation of the product.

8.3.2 Commissioning Test

The following tests should be performed on each installed link.

8.3.2.1 Link Verification

- Received Signal Level (RSL) is up to +/- 4 dB from the expected (calculated) level at both ends of the link.¹
- Radio Bit Error Rate (BER) is $10E^{-11}$ or lower.
- If working with ATPC, ATPC is operating as expected (RSL = reference level).

8.3.2.2 Ethernet Line Interfaces Test

- Connect Ethernet Packet Analyzer to the GbE port. Use physical loop at remote end (or connect second analyzer). Run Packet Loss test for at least one hour (load rate as per Ceragon's specifications for the chosen MRMC).
- Connect Ethernet Packet Analyzer to the FE port. Use physical loop at remote end (or connect second analyzer). Run Packet Loss test for at least one hour (load rate as per Ceragon's specifications for the chosen MRMC).

8.3.2.3 Interoperability Verification

- Connect customer end equipment to the line interfaces, and verify correct operation.
- Further interoperability tests should be performed in accordance with the specific requirements of the connected end equipment.

¹ The voltage at the BNC port is 1.XX where XX is the RSL level. For example: 1.59V means an RSL of -59 dBm. Note that the voltage measured at the BNC port is not accurate and should be used only as an aid).

8.3.2.4 Management Verification

- Launch the HTTP management and verify that you can manage the link and that you are able to perform changes to the link configuration (frequency channel, Tx power, system name, time & date, etc.)
- Verify that correct parameters are reported when performing the above.
- Verify that there are no active alarms on the link.
- If the management station is located at a remote site (Network Operation Center), verify that the management station can manage the link and receive traps.

8.4 IP-20 Commissioning Log

The Commissioning Log is an integral part of the commissioning procedure and should be filled in for each installed link.

The Commissioning Log gathers all relevant information regarding the installed link and contains a checklist of all recommended commissioning tests.

Maintaining the Commissioning Log is important for tracking your installations, and to provide essential data for Ceragon Networks.

Upon completing the Commissioning Log, send the log to Ceragon support center at support@ceragon.com.

IP-20 LINK COMMISSIONING LOG		
1. GENERAL INFORMATION		
Customer:		
Radio model:		
Configuration:		
Radio link code:		
Site 1 name & add:		
Site 2 name & add:		
2. ODU/RFU	Site 1	Site 2
ODU model:		
ODU p/n:		
ODU s/n:		
ODU SW:		
Tx frequency (MHz):		
Rx frequency (MHz):		
Link ID:		
Tx power (dBm):		

ATPC on/off:		
ATPC ref level:		
ODU Polarization:		
3. ANTENNA AND ODU MOUNT	Site 1	Site 2
Antenna vendor and model:		
Antenna size:		
Mounting type:		
Mounting losses:		
4. LINK PARAMETERS	Site 1	Site 2
Link distance:		
Rain zone:		
Expected RSL (dBm):		
Expected Diversity RSL (dBm):		
RSL Main (dBm):		
RSL Diversity (dBm):		
Deviation from exp?		
RSL \leq 4 dB?		
5. COMMISSIONING TESTS	Site 1	Site 2
Line loopback:	Pass	Pass
ODU loopback:	Pass	Pass
Radio BER:	Pass	Pass
FE test:	Pass	Pass
GbE test:	Pass	Pass
6. MANAGEMENT CONFIGURATION	Site 1	Site 2
Eth IP Address:		
Eth IP mask:		
Default router:		
In-band VLAN		
7. REMARKS/NOTES		

8. INSTALLATION INFORMATION	
Installed by:	Name:
	Company:
	Date:
	Signature:
Commissioned by:	Name:
	Company:
	Date:
	Signature: